



cycle fitments

P H I L L I P S C Y C L E F I T M E N T S



CONTENTS

Description	Page	Description	Page	Description	Page
Bracket Axles	30	Crank Cotters	34	Lamp Brackets	31
Bracket Cups	30	Cycle Stand	32	Mudguards	29
Brake Bottom Parts ..	22/23	Expander Bolts	34	Oil	29
Brake Spare Parts ..	24/26	Forks	28	Pedals	2/4
Cable Brakes	12/13	Frame Fittings, misc. ..	34	Pedal Spare Parts	5
Cables	14	Handlebars	17	Prop Stand	32
Cable Brake Levers ..	15	Handlebar Bends	18	Reflector	33
Cable Brake Spare Parts ..	16	Handlebars with Top Parts	20/21	Seat Pillars	33
Carded Spares	35	Handlebar Stems	19	Spanner	33
Chain Adjusters	34	Head Fittings	31	Spokes with Nipples ..	11
Chainguards	29	Hubs	6/8	Stabilisers	32
Chainwheels and Cranks ..	27	Hub Spindles	9		
		Hub Spare Parts	10		

RALEIGH INDUSTRIES LIMITED
NOTTINGHAM ENGLAND

Telephone: NOTTINGHAM 77761

A Member of the  Group of Companies

Printed in England

PHILLIPS CYCLE FITMENTS

RUBBER PEDALS

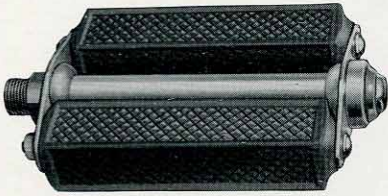

PEA 505
PEA 501



PEA 608

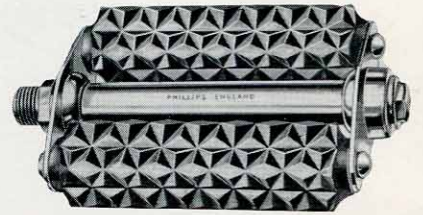

PEA 605



PEA 628



PEA 623



PEA 510
PEA 515

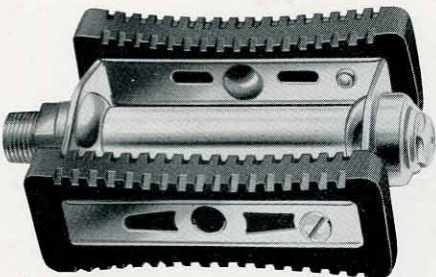

PEA 624



PEA 527



PEA 531

When ordering please quote Sales Number

P H I L L I P S G Y C L E F I T M E N T S

RUBBER PEDALS

J. A. PHILLIPS have been famous for the manufacture of pedals for more than 65 years. All the vast experience and knowledge accumulated over the years have resulted in the development of the comprehensive range of Roadster, Sports, Tourist and Carrier pedals illustrated in this catalogue. The models differ in style and design but they all have in common the quality and reliability for which the name of PHILLIPS is famous the world over.

Sales No. (Pair)	Former List No.	Spindle Thread	Rubber		Description
			Length	Colour	
PEA 501	65	$\frac{9}{16}$ "	4"	Black	Gent's Small Diamond Rubber
PEA 502	"	"	"	White	" " " "
PEA 503	"	$\frac{1}{2}$ "	"	"	" " " "
PEA 504	"	"	"	Black	" " " "
PEA 505	66	$\frac{9}{16}$ "	3 $\frac{1}{2}$ "	Black	Lady's Small Diamond Rubber
PEA 506	"	"	"	White	" " " "
PEA 508	"	$\frac{1}{2}$ "	"	"	" " " "
PEA 509	"	"	"	Black	" " " "
PEA 608	58	$\frac{9}{16}$ "	3"	Black	Kiddies' Extruded Rubber
PEA 609	"	"	"	White	" " " "
PEA 610	"	$\frac{1}{2}$ "	"	Black	" " " "
PEA 605	98	$\frac{9}{16}$ "	4 $\frac{1}{2}$ "	Black	Large Diamond Rubber
PEA 606	"	"	"	"	" " " (Enamel Finish)
PEA 628	84	$\frac{9}{16}$ "	4 $\frac{1}{2}$ "	Black	Heavy Carrier, Large Diamond Rubber
PEA 623	152	$\frac{9}{16}$ "	4"	Black	All Rubber
PEA 510	125	$\frac{9}{16}$ "	4"	Black	Gent's Small Diamond 'Reflex' Rubber
PEA 514	"	$\frac{1}{2}$ "	"	"	" " " " "
PEA 515	126	$\frac{9}{16}$ "	3 $\frac{1}{2}$ "	Black	Lady's Small Diamond 'Reflex' Rubber
PEA 518	"	$\frac{1}{2}$ "	"	"	" " " " "
PEA 624	202	$\frac{9}{16}$ "	3"	Black	Lightweight, Moulded Rubber Treads
PEA 625	"	"	"	White	" " " "
PEA 527	22	$\frac{9}{16}$ "	3 $\frac{3}{4}$ "	Black	Small Diamond 'Bow' Rubber
PEA 528	"	"	"	White	" " " "
PEA 529	"	$\frac{1}{2}$ "	"	Black	" " " "
PEA 530	"	"	"	White	" " " "
PEA 531	25	$\frac{9}{16}$ "	3 $\frac{3}{4}$ "	Black	Small Diamond 'Bow' Rubber
PEA 532	"	"	"	White	" " " "
PEA 533	"	$\frac{1}{2}$ "	"	Black	" " " "
PEA 534	"	"	"	White	" " " "

When ordering please quote Sales Number

PHILLIPS CYCLE FITMENTS

ALL-METAL PEDALS

In the Phillips range of All-Metal Pedals, there is a model to suit every type of rider. Each model has been evolved after a great deal of thought and study of the varying requirements of sports riders throughout the world.

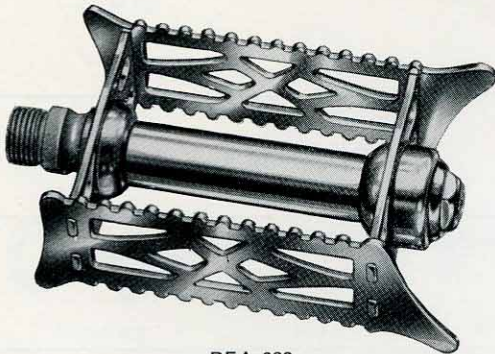

PEA 632

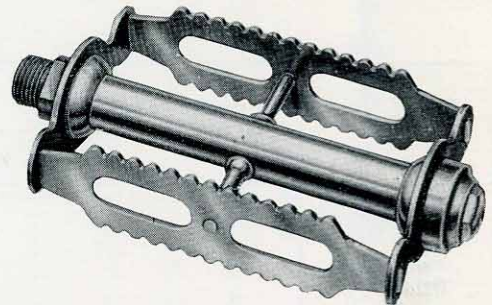

PEA 535

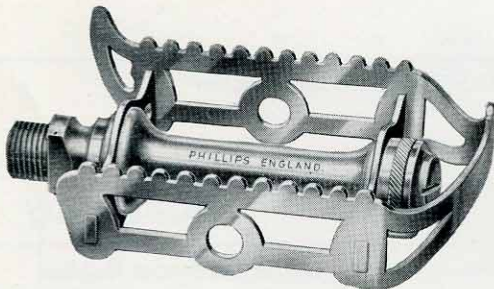

PEA 630

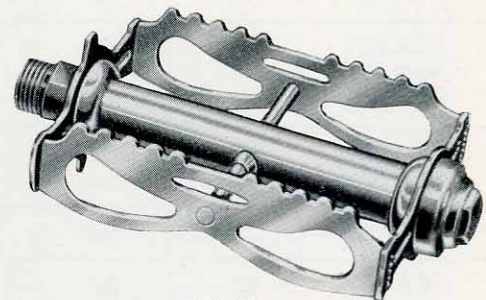

PEA 631







Sales No. (Pair)	Former List No.	Spindle Thread	Description
PEA 632 PEA 633	83 "	$\frac{9}{16}$ " $\frac{1}{2}$ "	Lightweight "
PEA 535 PEA 629 PEA 630	61 " 101	$\frac{9}{16}$ " $\frac{1}{2}$ " $\frac{9}{16}$ "	Rat-Trap " Solid Centre, 'Quill' Pattern
PEA 631	717	$\frac{9}{16}$ "	Continental Lightweight

All models fitted with $\frac{5}{32}$ " balls throughout and with adjustable bearings.

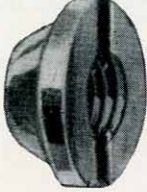
When ordering please quote Sales Number

P H I L L I P S G Y C L E F I T M E N T S

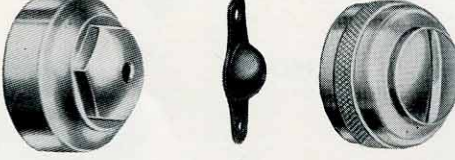
SPARE PARTS FOR PEDALS

	DESCRIPTION	SALES No.	FORMER LIST No.	SUITABLE FOR:
 Spindle Units	SPINDLE UNITS (Pairs)	PER 801 PER 802 PER 803 PER 804 PER 805 PER 806 PER 807 PER 809 PER 810 PER 811 PER 812 PER 813 PER 814 PER 815	P 127x P 133x P 127x P 133x P 134x P 141x P 134x P 130x P 148x P 110x P 128x P 128x	PEA 501, PEA 502, PEA 510, PEA 519, PEA 523, PEA 535, PEA 505, PEA 506, PEA 515, PEA 521, PEA 525, PEA 631, PEA 503, PEA 504, PEA 514, PEA 520, PEA 524, PEA 629, PEA 508, PEA 509, PEA 518, PEA 522, PEA 526 PEA 608, PEA 609 PEA 605 PEA 606 PEA 610 PEA 527, PEA 528, PEA 531, PEA 532, PEA 623 PEA 529, PEA 530, PEA 533, PEA 534 PEA 630 PEA 624, PEA 625
 Cone PEK 101	CONE	PEK 101	P 203	All Pedals
 Lock Washer PMW102	LOCKWASHER	PMW 102	W 1002	All Pedals
 Lock Nut PMN 102	LOCKNUT	PMN 102	N 1003	All Pedals
 Rubber Bar and Nut	RUBBER BAR AND NUT	PEM 102 PEM 103 PEM 104 PEM 105 PEM 106 PEM 107	P 720x P 721x P 719x P 723x B 706x	PEA 505 to PEA 509, PEA 518, PEA 525, PEA 526, PEA 515 PEA 501 to PEA 504, PEA 510, PEA 514, PEA 523, PEA 524 PEA 608 to PEA 610 PEA 605, PEA 606 PEA 531 to PEA 534 PEA 628
 Rubber Bar and Nut	RUBBER BAR NUT " " LOCKNUT	PMN 103 PMN 269	N 601 N 610	All Pedals PEA 628
 DUSTCAPS PEL 801 PEL 802 PEL 803	DUSTCAPS	PEL 501 PEL 801 PEL 802 PEL 803	P 515 P 504 P 516	PEA 519 to PEA 534 PEA 501 to PEA 518, PEA 535, PEA 605, PEA 606, PEA 608 to PEA 610, PEA 624, PEA 625, PEA 629 to PEA 633 PEA 628 PEA 630
 Rubber	RUBBERS	PED 106 PED 110 PED 121 PED 125 PED 134 PED 135 PED 136 PED 137 PED 801 PED 802 PED 803 PED 805 PED 806 PED 807 PED 808 PED 809 PED 811	P 601 " P 602 P 602 P 616 " P 688 " P 605	PEA 501, PEA 504, PEA 519, PEA 523, PEA 524 PEA 502, PEA 503 PEA 505, PEA 509, PEA 521, PEA 522, PEA 525, PEA 526 PEA 506, PEA 508 PEA 608, PEA 610 PEA 609 PEA 624 PEA 625 PEA 605, PEA 606 PEA 531, PEA 533 PEA 532, PEA 534 PEA 527, PEA 529 PEA 528, PEA 530 PEA 623 PEA 628 PEA 510, PEA 514 PEA 515, PEA 518

When ordering please quote Sales Number

P H I L L I P S C Y C L E F I T M E N T S

HUBS

All Phillips Hubs, from the robust large-barrelled models to the slender Continental large flange models, are manufactured from best grade materials throughout, and fully guaranteed to conform with Phillips standard of quality and efficiency.

Sales No.	Former List No.	Length of Spindle	Drilling	Diameter of Spindle	Diameter of Balls	Chainline
PHA 509	37	4 $\frac{1}{2}$ "	32H	3/8"	1/4"	—
PHA 510	37	4 $\frac{1}{2}$ "	32H	3/8"	1/4"	—
PHA 511	37	4 $\frac{1}{2}$ "	36H	3/8"	1/4"	—
PHJ 502	39	5 $\frac{1}{2}$ "	40H	3/8"	1/4"	1 $\frac{1}{2}$ "
PHJ 503	39	6 $\frac{1}{2}$ "	40H	3/8"	1/4"	1 $\frac{1}{2}$ "
PHJ 504	39	6 $\frac{1}{2}$ "	36H	3/8"	1/4"	1 $\frac{1}{2}$ "
PHA 504	22	4 $\frac{1}{2}$ "	20H	5/16"	3/8"	—
PHJ 501	23	4 $\frac{1}{2}$ "	20H	5/16"	3/8"	1 $\frac{5}{16}$ "
PHJ 514	42	6 $\frac{1}{2}$ "	40H	3/8"	1/4"	1 $\frac{3}{4}$ "

All models are finished in chromium plate except PHA 510 and PHJ 514 which are finished in black enamel.

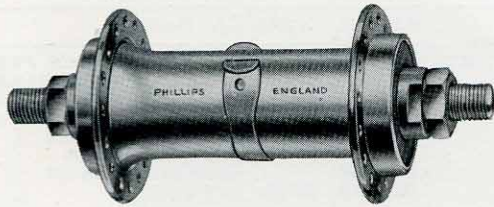

PHA 509

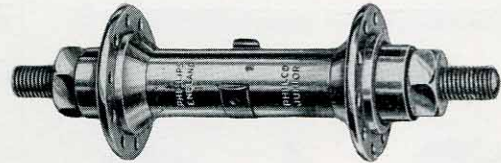

PHA 504

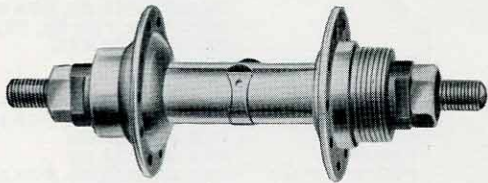

PHJ 501

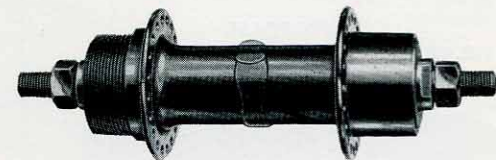

PHJ 514

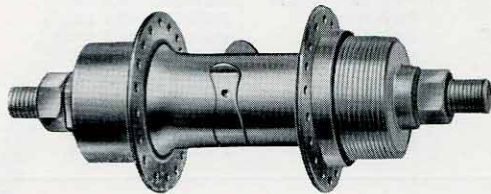

PHJ 502

When ordering please quote Sales Number

PHILLIPS CYCLE FITMENTS

HUBS

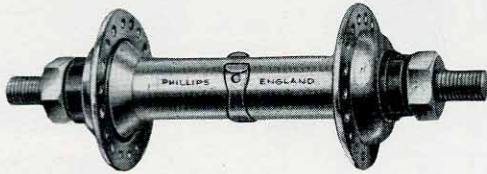

PHA 501

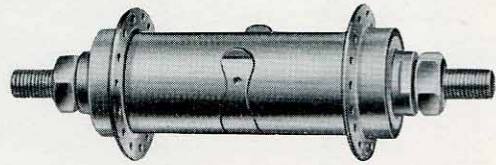

PHA 505

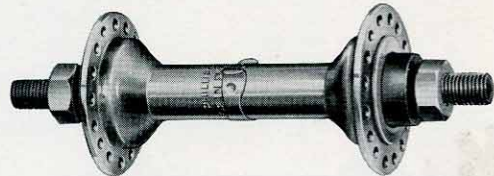

PHA 506

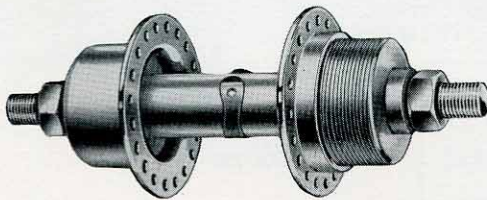

PHJ 505

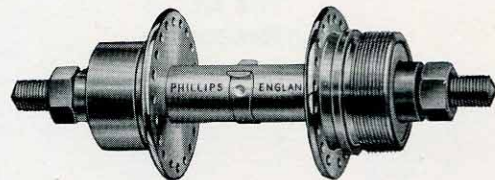

PHJ 510

Sales No.	Former List No.	Length of Spindle	Drilling	Diameter of Spindle	Diameter of Balls	Chainline
PHA 501	67	4 $\frac{15}{16}$ "	32H	$\frac{5}{16}$ "	$\frac{3}{16}$ "	—
PHA 502	67	4 $\frac{15}{16}$ "	36H	$\frac{5}{16}$ "	$\frac{3}{16}$ "	—
PHJ 505	68	5 $\frac{11}{16}$ "	40H	$\frac{3}{8}$ "	$\frac{1}{4}$ "	1 $\frac{1}{2}$ "
PHJ 506	68	5 $\frac{11}{16}$ "	36H	$\frac{3}{8}$ "	$\frac{1}{4}$ "	1 $\frac{1}{2}$ "
PHJ 507	68	6 $\frac{1}{2}$ "	40H	$\frac{3}{8}$ "	$\frac{1}{4}$ "	1 $\frac{1}{2}$ "
PHA 505	36	4 $\frac{15}{16}$ "	32H	$\frac{5}{16}$ "	$\frac{3}{16}$ "	—
PHA 506	167	5"	32H	$\frac{5}{16}$ "	$\frac{3}{16}$ "	—
PHJ 510	168	5 $\frac{11}{16}$ "	40H	$\frac{3}{8}$ "	$\frac{1}{4}$ "	1 $\frac{1}{2}$ "
PHJ 511	168	6 $\frac{1}{2}$ "	40H	$\frac{3}{8}$ "	$\frac{1}{4}$ "	1 $\frac{1}{2}$ "
PHJ 512	169	5 $\frac{11}{16}$ "	40H	$\frac{3}{8}$ "	$\frac{1}{4}$ "	1 $\frac{1}{2}$ "
PHJ 513	169	6 $\frac{1}{2}$ "	40H	$\frac{3}{8}$ "	$\frac{1}{4}$ "	1 $\frac{1}{2}$ "

When ordering please quote Sales Number

PHILLIPS CYCLE FITMENTS

HUBS

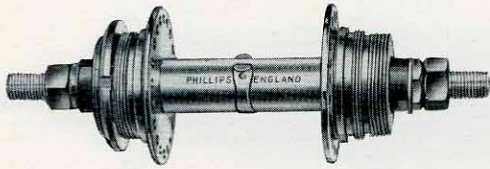

PHJ 515

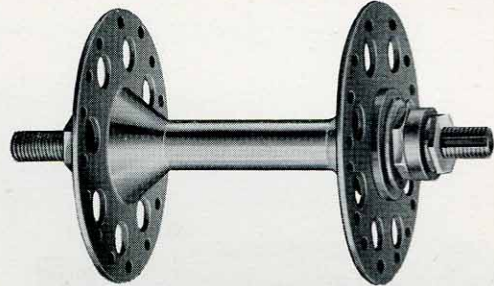

PHA 701

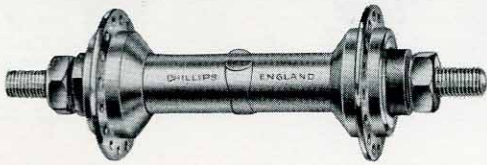

PHA 507
PHA 508

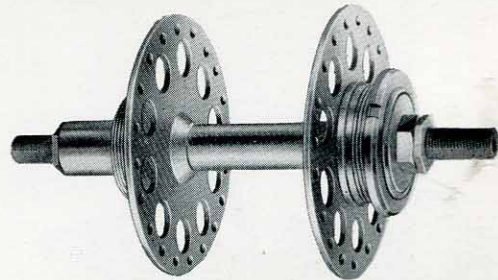

PHA 702

Sales No.	Former List No.	Length of Spindle	Drilling	Diameter of Spindle	Diameter of Balls	Chainline
PHJ 515	170	5 $\frac{1}{16}$ "	40H	$\frac{3}{8}$ "	$\frac{1}{4}$ "	1 $\frac{1}{2}$ "
PHA 507	546	4 $\frac{1}{16}$ "	32H	$\frac{5}{16}$ "	$\frac{3}{16}$ "	—
PHA 508	546	4 $\frac{1}{16}$ "	36H	$\frac{5}{16}$ "	$\frac{3}{16}$ "	—
PHA 701	557	4 $\frac{1}{16}$ "	32H	$\frac{5}{8}$ "	$\frac{3}{16}$ "	—
PHJ 702	560	6 $\frac{7}{16}$ "	40H	$\frac{3}{8}$ "	$\frac{1}{4}$ "	1 $\frac{1}{2}$ "

When ordering please quote Sales Number

PHILLIPS CYCLE FITMENTS

HUB SPINDLES



PHB 519

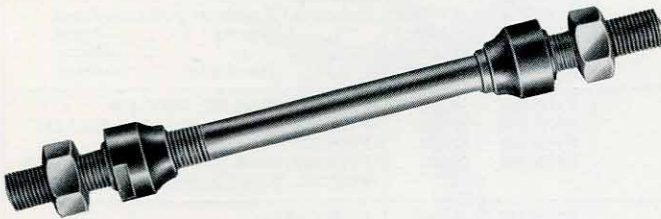

PHB 522



PHB 520

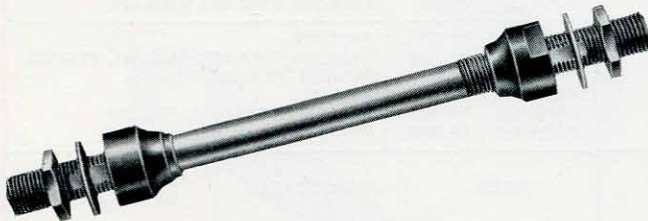

PHB 521

Sales No.	Former List No.	Description
PHB 519	H115K	Standard Hub Spindle, Front ($5'' \times \frac{5}{16}''$ with $\frac{3}{8}''$ dia. cones, complete with outside nuts).
PHK 522	H107X	Standard Hub Spindle, Rear ($6'' \times \frac{3}{8}''$ with $\frac{1}{16}''$ dia. cones, complete with outside nuts).
PHB 520	H144K	Sports Hub Spindle, Front ($5\frac{1}{4}'' \times \frac{5}{16}''$ with $\frac{3}{8}''$ dia. cones, complete with locknuts and washers).
PHK 521	H154A	Sports Hub Spindle, Rear ($6\frac{1}{2}'' \times \frac{3}{8}''$ with $\frac{1}{16}''$ dia. cones, complete with locknuts and washers).

The hub spindles shown on this page are specially designed and manufactured for general replacement purposes.

One or another is interchangeable with the spindle fitted to any one of the majority of cycle hubs now in use, and Dealers need not stock a wide variety of patterns to cater for the normal every-day demand.

These spindles are manufactured from the same best quality material, and are precision engineered, exactly as the spindles fitted to Phillips hubs. The cones are made from special steel and scientifically case-hardened and tested.

When ordering please quote Sales Number

P H I L L I P S C Y C L E F I T M E N T S

SPARE PARTS FOR HUBS

	DESCRIPTION	SALES No.	FORMER LIST No.	SUITABLE FOR HUB		
 SPINDLE UNITS	SPINDLE UNIT	PHB 501 PHB 503 PHB 504 PHB 507 PHB 513 PHB 515 PHB 812 PHK 507 PHK 508 PHK 513 PHK 515 PHK 516 PHK 818 PHB 519 PHB 520 PHK 521 PHK 522	H 115x " " H 109x H 114x H 101x H 121x H 106x H 117x H 154x H 113x H 110x H 115k H 144k H 154a H 107x	PHA 501, PHA 502, PHA 505, PHA 507, PHA 508 PHA 503 PHJ 501 PHA 504 PHA 506 PHA 509, PHA 510, PHA 511 PHA 701 PHJ 502, PHJ 505, PHJ 506, PHJ 512 PHJ 503, PHJ 504, PHJ 507, PHJ 513 PHJ 508, PHJ 509, PHJ 511 PHJ 514 PHJ 515 PHJ 702 Universal Roadster pattern—Front " Sports " —Front " " " —Rear " Roadster " —Rear		
 Cup PHN 502 Cup PHN 504 Cup PHN 503 Cup PHN 501	CUPS	PHN 501 PHN 502 PHN 503 PHN 504	H 411 H 401 H 409 H 402	PHA 506, PHA 507, PHA 508 PHJ 502, PHJ 503, PHJ 504, PHJ 514 PHA 505 PHA 509, PHA 510, PHA 511, PHJ 510, PHJ 511, PHJ 513, PHJ 515		
 Washer locknut and outside nut	OUTSIDE NUTS	PMN 117 PMN 118	N 1001 N 1201	$\frac{5}{16}$ " Spindles $\frac{3}{8}$ " Spindles		
	LOCK NUTS	PMN 112 PMN 114	N 1002 N 1203	$\frac{7}{16}$ " Spindles $\frac{3}{8}$ " Spindles		
	WING NUTS	PMN 270 PMN 271	199 198	$\frac{5}{16}$ " Spindles $\frac{3}{8}$ " Spindles		
	TRACK NUTS	PMN 272 PMN 273	N 1016x N 1209x	$\frac{5}{16}$ " Spindles $\frac{3}{8}$ " Spindles		
	HELMET TRACK NUTS	PMN 279 PMN 280	N 1019x N 1214x	$\frac{5}{16}$ " Spindles $\frac{3}{8}$ " Spindles		
 Helmet Nut Wing Nut	LOCK RING	PHM 801	H 902	All Standard Hubs		
 Track Nut	LUBRICATOR	PHM 116	M 101	All Standard Hubs		
	LUBRICATOR BANDS	PHP 101 PHP 102 PHP 103 PHP 104	M 109 M 103 M 106 M 104	PHA 507, PHA 508 PHA 501 to PHA 504, PHJ 501 PHA 505, PHA 509, PHA 510, PHA 511, PHJ 502 to PHJ 504 PHJ 505 to PHJ 513, PHJ 515		
	DUST CAP	PHM 115	H 508	PHA 506, PHA 507, PHA 508		
	CLOSURE WASHERS	PMW 113 PMW 114 PMW 115 PMW 117 PMW 118	W 2212 W 2210 W 1601 W 2211 W 1803	PHA 505 PHA 509, PHA 510, PHA 511, PHJ 502, PHJ 503, PHJ 504, PHJ 514 PHA 701 PHJ 510 to PHJ 513, PHJ 515 PHJ 702		
 Lubricator Band Closure Washer	CONES					
			FIXED	ADJUSTABLE	SUITABLE FOR SPINDLE UNIT	
			SALES No.	FORMER LIST No.	SALES No.	
			FORMER LIST No.	SALES No.	FORMER LIST No.	
			PHR 801	H 201	PHR 123	H 202
			PHR 107	H 203	PHR 117	H 204
			PHR 805 PHR 102 PHR 101	H 210 H 212 H 208	PHR 804 PHR 113 PHR 114	H 209 H 211 H 207
			PHR 803	H 214	PHR 802 PHR 103 (2 off)	H 213 H 235x
			PHR 108	H 234x	PHR 118	H 231x
						PHK 507, PHK 508, PHK 515 PHK 509 to PHK 514, PHK 516, PHK 517, PHK 519, PHK 520, PHB 515 to PHB 517 PHB 514 PHB 501, PHB 511 PHB 502 to PHB 510, PHB 518, PHK 501 to PHK 506 PHB 513 PHB 812 PHK 818
 Spigotted Flat						

When ordering please quote Sales Number

PHILLIPS CYCLE FITMENTS

SPOKES WITH NIPPLES

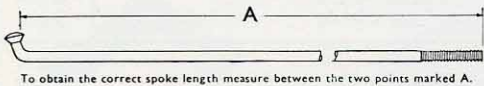
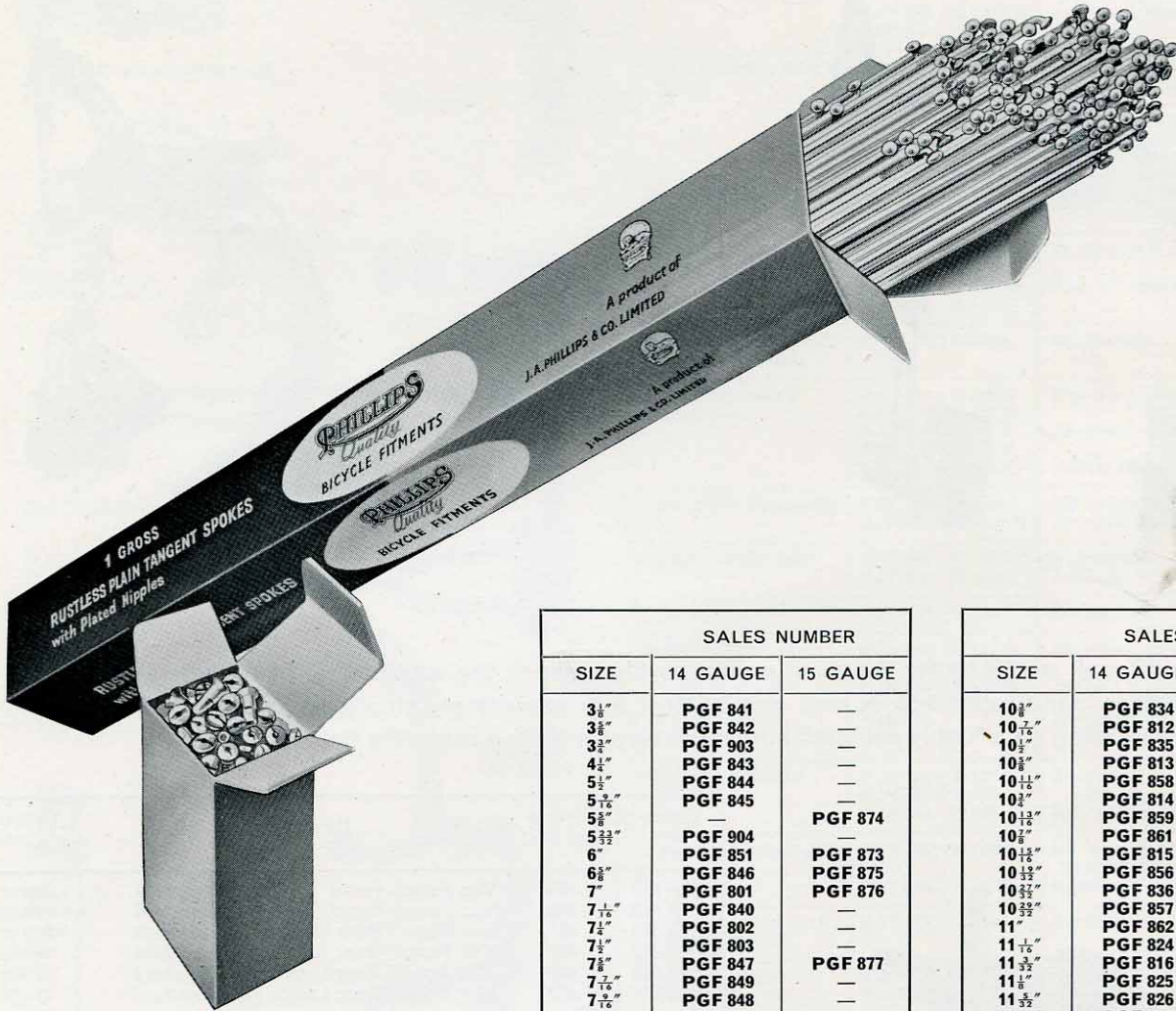

To obtain the correct spoke length measure between the two points marked A.

	14 gauge	15 gauge
Nipples only	PGB 101	PGB 801
Washers only	PMW 399	PMW 399

SIZE	SALES NUMBER	
	14 GAUGE	15 GAUGE
3½"	PGF 841	—
3¾"	PGF 842	—
3⅝"	PGF 903	—
4¼"	PGF 843	—
5¼"	PGF 844	—
5⅝"	PGF 845	—
5⅞"	—	PGF 874
5¾"	PGF 904	—
6"	PGF 851	PGF 873
6⅝"	PGF 846	PGF 875
7"	PGF 801	PGF 876
7⅛"	PGF 840	—
7¼"	PGF 802	—
7½"	PGF 803	—
7⅞"	PGF 847	PGF 877
7⅞"	PGF 849	—
7⅞"	PGF 848	—
8"	PGF 850	—
8⅛"	PGF 804	—
8⅜"	PGF 805	—
8⅝"	PGF 838	—
8⅞"	PGF 806	—
8⅞"	—	PGF 878
8⅞"	PGF 852	PGF 879
8⅞"	PGF 807	PGF 880
8⅞"	—	PGF 881
8⅞"	PGF 839	—
8⅞"	PGF 808	—
8⅞"	PGF 853	—
9"	PGF 905	—
9⅛"	PGF 837	—
9⅜"	PGF 854	—
9⅝"	PGF 809	—
9⅞"	PGF 855	—
10⅞"	PGF 831	—
10⅞"	PGF 810	PGF 882
10⅞"	PGF 832	PGF 883
10⅞"	PGF 811	PGF 885
10⅞"	PGF 833	—
10⅞"	PGF 860	PGF 886

SIZE	SALES NUMBER	
	14 GAUGE	15 GAUGE
10⅞"	PGF 834	—
10⅞"	PGF 812	—
10⅞"	PGF 813	—
10⅞"	PGF 835	PGF 884
10⅞"	PGF 858	—
10⅞"	PGF 814	—
10⅞"	PGF 859	—
10⅞"	PGF 861	—
10⅞"	PGF 815	—
10⅞"	PGF 856	—
10⅞"	PGF 836	—
10⅞"	PGF 857	—
10⅞"	PGF 862	PGF 887
10⅞"	PGF 824	—
10⅞"	PGF 816	—
10⅞"	PGF 825	PGF 888
10⅞"	PGF 826	—
10⅞"	PGF 827	PGF 889
10⅞"	PGF 864	PGF 890
10⅞"	PGF 817	—
10⅞"	PGF 865	PGF 891
10⅞"	PGF 866	PGF 892
10⅞"	PGF 818	—
10⅞"	—	PGF 893
10⅞"	PGF 863	—
10⅞"	PGF 867	PGF 894
10⅞"	PGF 828	—
10⅞"	PGF 819	—
10⅞"	PGF 829	—
10⅞"	PGF 820	PGF 895
10⅞"	PGF 830	—
10⅞"	PGF 869	PGF 896
10⅞"	PGF 821	—
10⅞"	PGF 870	PGF 897
10⅞"	PGF 822	PGF 902
10⅞"	PGF 823	PGF 898
10⅞"	PGF 871	PGF 899
10⅞"	—	PGF 900
10⅞"	PGF 872	PGF 901

When ordering please quote Sales Number

P H I L L I P S C Y C L E F I T M E N T S

CABLE BRAKE SETS

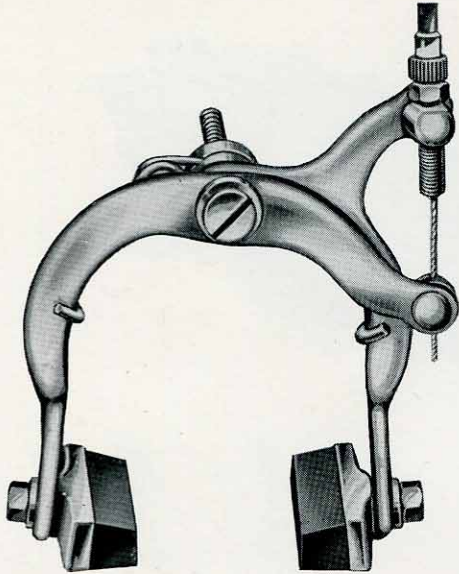

PKA 801



PKB 801

The Vox Populi is still by far the most popular cycle brake in the world. It is beautifully styled and because it is manufactured from best quality steel it is exceedingly strong and efficient. Superfine chromium plating on a highly polished surface ensures a lasting mirrorlike finish.

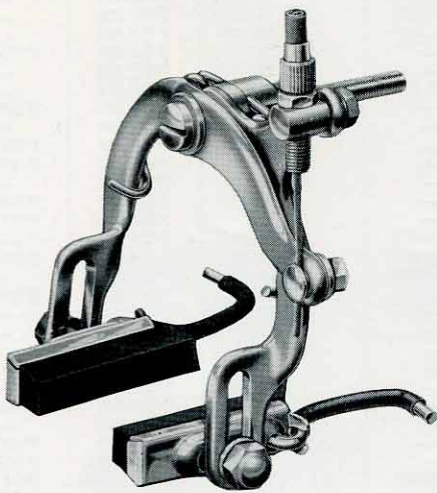

PKA 815

Sales No.	Former List No.	Description		Colour of Cable
PKA 801	400	Vox Populi Front	Standard	Silver
PKA 802	400	Vox Populi Front	Standard	White
PKB 801	401	Vox Populi Rear Gent's	Standard	Silver
PKB 803	401	Vox Populi Rear Gent's	Standard	White
PKB 802	402	Vox Populi Rear Lady's	Standard	Silver
PKB 804	402	Vox Populi Rear Lady's	Standard	White
PKA 811	669	Vox Populi Front	Junior	White
PKB 821	670	Vox Populi Rear Boy's	Junior	White
PKB 822	671	Vox Populi Rear Girl's	Junior	White
PKA 815	850	Ventura Front		Silver
PKB 830	851	Ventura Rear Gent's		Silver
PKB 841	852	Ventura Rear Lady's		Silver
PKA 501	115	Philco Front		Silver
PKB 501	116	Philco Rear Gent's		Silver
PKB 502	117	Philco Rear Lady's		Silver
PKA 816	405	Westwood Front		Silver
PKB 831	444	Westwood Rear (Bottom Bracket Fitting)		Silver
PKB 832	410	Westwood Rear (Seat Stay Fixing)		Silver

All Models are supplied complete with cable and PKL 105 (No. 11) Levers. Alternative Levers PKL 106/PKL 111 (No. 14) or PKL 108 (No. 18) fitted to order.

When ordering please quote Sales Number

PHILLIPS CYCLE FITMENTS

CABLE BRAKE SETS

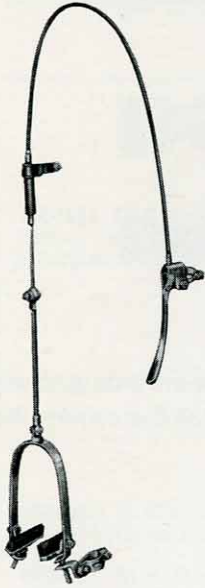

PKA 816

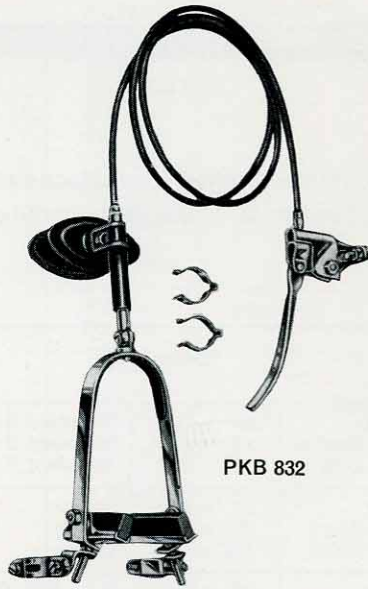

PKB 832

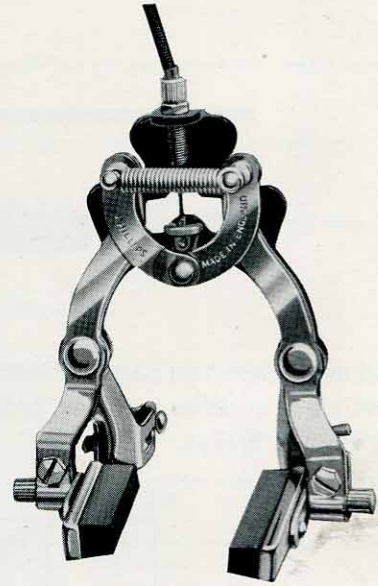

PKA 501

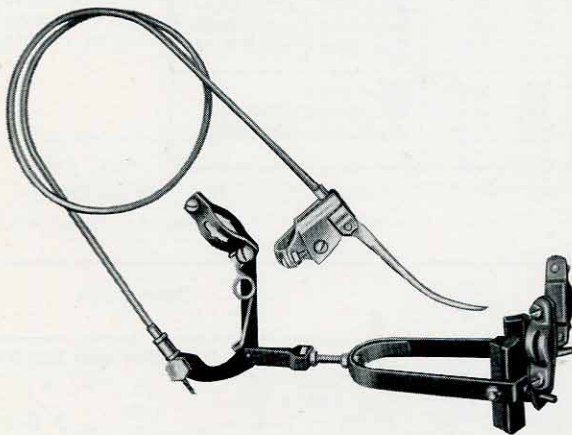

PKB 831

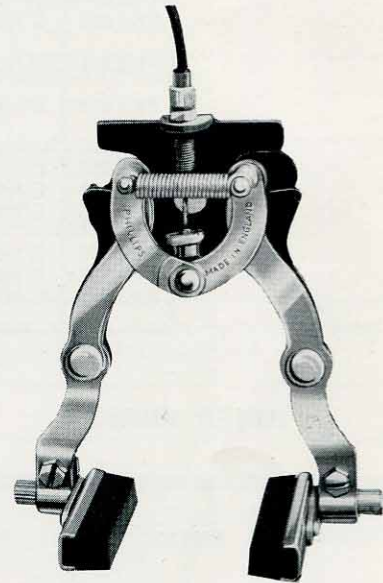

PKB 501
PKB 502

When ordering please quote Sales Number

PHILLIPS CYCLE FITMENTS

BRAKE CABLES



PKJ 801



PKJ 810



PKJ 813

All the component parts of Phillips Brake Cables supplied for replacement purposes are manufactured entirely in our own factories, and are guaranteed to be of the same quality and finish as the cables fitted to Phillips brakes.

Sales No.	Former List No.	Description		
PKJ 801	C 1841c	Front	20" × 24 $\frac{1}{2}$ "	Standard Side-Pull
PKJ 802	C 1842c	Rear Gent's	43" × 47 $\frac{1}{2}$ "	Standard Side-Pull
PKJ 803	C 1843c	Rear Lady's	54" × 58 $\frac{1}{2}$ "	Standard Side-Pull
PKJ 804	C 1841c	Front	16" × 19 $\frac{3}{4}$ "	Junior
PKJ 805	C 1842c	Rear Boy's	36 $\frac{1}{4}$ " × 39 $\frac{3}{4}$ "	Junior
PKJ 806	C 1843c	Rear Girl's	45 $\frac{3}{4}$ " × 49 $\frac{7}{8}$ "	Junior
PKJ 810	C 1850c	Front	20" × 24 $\frac{1}{4}$ "	Side-Pull, Barrel Nipple Type
PKJ 811	C 1851c	Rear Gent's	43" × 47 $\frac{1}{2}$ "	Side-Pull, Barrel Nipple Type
PKJ 812	C 1852c	Rear Lady's	54" × 58 $\frac{1}{2}$ "	Side-Pull, Barrel Nipple Type
PKJ 813	C 1801x	Front	20" × 23"	Standard Centre Pull
PKJ 814	C 1802x	Rear Gent's	43" × 46"	Standard Centre Pull
PKJ 815	C 1803x	Rear Lady's	54 $\frac{1}{4}$ " × 57 $\frac{1}{4}$ "	Standard Centre Pull
PKJ 816	C 1825x	Front	20 $\frac{1}{4}$ " × 22 $\frac{3}{8}$ "	Westwood
PKJ 817	C 1826x	Rear	42 $\frac{7}{8}$ " × 45 $\frac{1}{2}$ "	Westwood (PKB 832)
PKJ 818	C 1834x	Rear	38 $\frac{7}{8}$ " × 43 $\frac{7}{8}$ "	Westwood (PKB 831)

INNER WIRES



PKJ 850



PKJ 853

Sales No.	Former List No.	Description
PKJ 850	C 1853T	Front 30"—075" Wire with Ball Nipple
PKJ 851	C 1854T	Rear Gent's 54"— " " " "
PKJ 852	C 1855T	" Lady's 58"— " " " "
PKJ 853	C 1856T	Front 30"— " " " $\frac{1}{4}$ " Barrel Nipple
PKJ 854	C 1857T	Rear Gent's 54"— " " " " "
PKJ 855	C 1858T	" Lady's 58"— " " " " "

When ordering please quote Sales Number

PHILLIPS CYCLE FITMENTS

CABLE BRAKE LEVERS

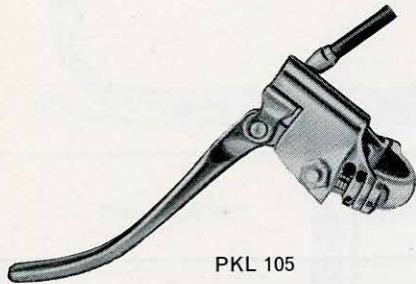

PKL 105



PKL 106
PKL 111

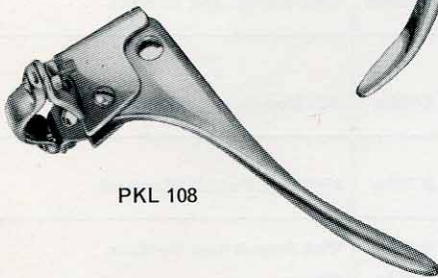

PKL 108



PKL 801
PKL 802

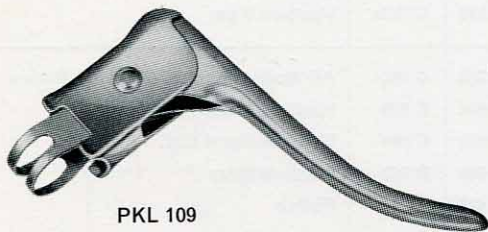

PKL 109



PKL 110

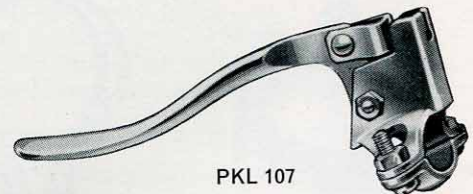





PKL 107

Sales No.	Former List No.	Description
PKL 105	11	Tourist with solid forged lever
PKL 803	—	Tourist with $\frac{3}{8}$ " dia. handlebar clips
PKL 106	14	Tourist, hooded pattern with one piece bracket and clip L.H.
PKL 111	14	Tourist, hooded pattern with one piece bracket and clip R.H.
PKL 107	16	Special Sports
PKL 108	18	Tourist, with solid forged lever
PKL 109	24	Sports, hooded pattern, with concealed clip fitting
PKL 801	23	Tourist, hooded pattern, with concealed clip fitting ($\frac{7}{8}$ " clip)
PKL 802	23	Tourist, hooded pattern, with concealed clip fitting ($\frac{1}{2}$ " clip)
PKL 110	25	Sports, hooded pattern, with concealed clip fitting. Heat hardened light alloy lever, and aluminium bracket

When ordering please quote Sales Number

P H I L L I P S C Y C L E F I T M E N T S

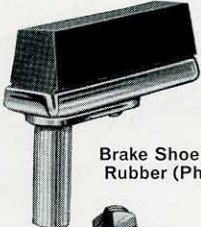
SPARE PARTS FOR CABLE BRAKES

	DESCRIPTION	SALES No.	FORMER LIST No.	SUITABLE FOR:
 Cable Adjuster  Adaptor Lug	CABLE ADJUSTER UNIT	PKM 112	C 1301x	All Models except Westwood
 Cable Anchor Pin, Nut and Washer  Centre Bolt Unit	ADAPTOR LUG UNIT	PKM 113	C 1304x	Vox Populi and Ventura
 Leg Spring (Philco)	CABLE ANCHOR PIN, NUT AND WASHER	PMP 126	S 825x	All Models except Philco
 Leg Spring (Vox Populi)  Brake Shoe and Rubber (Philco)	CENTRE BOLT UNIT, FRONT	PKM 802	S 806v	2 $\frac{1}{4}$ " Vox Populi Standard
 Brake Shoe and Rubber (PKP 103)  Brake Shoe and Rubber (PKP 102)	CENTRE BOLT UNITS, REAR	PKM 105 PKM 803	S 815v S 810x	Vox Populi and Ventura Philco
 Brake Shoe and Rubber (PKP 104/5)  Brake Rubber	LEG SPRING	PKM 806 PKM 110	Q 701 Q 306	Philco Vox Populi and Ventura
 Cable Clip  Lever Clip	BRAKE SHOE AND RUBBER	PKP 801 PKP 802 PKP 102 PKP 103 PKP 104 PKP 105 PKP 803	C 204x C 205x C 201x C 209x C 217x ,, C 218x	Philco Front Philco Rear All Front except Philco and Ventura All rear except Philco and Ventura Ventura Front R.H. Ventura Front L.H. Ventura Rear
	BRAKE RUBBER ONLY	PKS 802 PKS 804 PKS 805 PKS 806 PKS 803	C 602 C 609 C 609 C 603	All Models except Ventura, Philco Ventura Front R.H. Ventura Front L.H. Ventura Rear Philco
	SHOE PIN AND NUT	PMP 185 PMP 186 PMP 187	S 805x	All Models except Ventura Ventura Front Ventura Rear
	CABLE CLIP	PKM 805	C 1622	All Models
	LEVER CLIP	PKM 811	C 1608	All Models

When ordering please quote Sales Number

PHILLIPS CYCLE FITMENTS

HANDLEBARS (WITHOUT LEVERS)

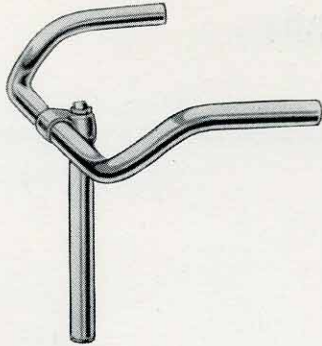

PNA 508

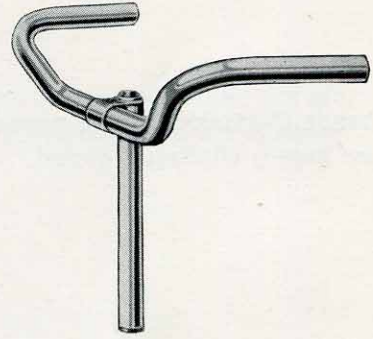

PNA 507



PNA 802

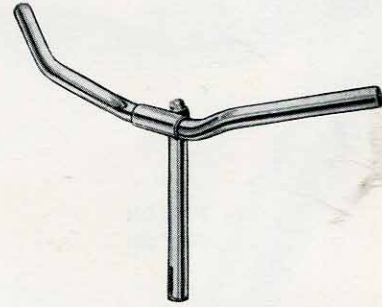

PNA 801

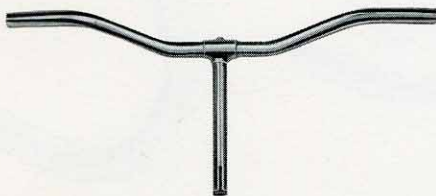

PNA 803

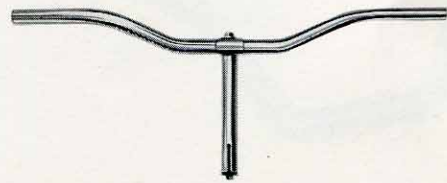

PNA 805

Sales No.	Former List No.	Description
PNA 507	85	Ordinary Raised, 18" wide
PNA 508	87	North Road Raised, 19" "
PNA 802	135	Light Tourist, 20" "
PNA 801	181	Allrounder, 19 $\frac{1}{4}$ " "
PNA 803	556	" " " 21 $\frac{1}{2}$ " "
PNA 805	723	Junior Allrounder, 19 $\frac{3}{4}$ " " ($\frac{3}{8}$ " x $\frac{3}{4}$ ")

All models constructed with $\frac{7}{8}$ " dia. tubing, except PNA 805 which is constructed with $\frac{3}{4}$ " dia. tubing. All models fitted with expander bolts and heavily chromium plated.

When ordering please quote Sales Number

P H I L L I P S C Y C L E F I T M E N T S

HANDLEBAR BENDS

The bends illustrated on this page are made from high grade steel tubing, $\frac{7}{8}$ " diameter, with $\frac{15}{16}$ " ferrules, and are heavily chromium plated.

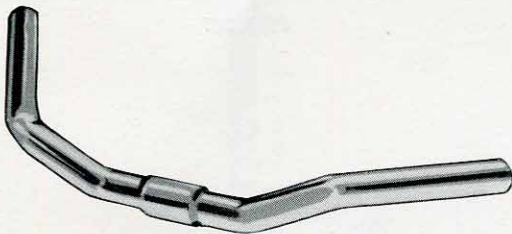

PNH 601
PNH 603

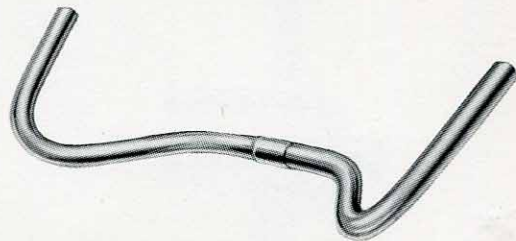

PNH 602



PNH 604

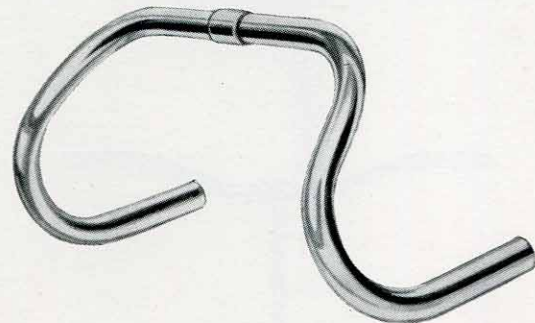

PNH 605

Sales No.	Former List No.	Description
PNH 601	368	Allrounder— 22" wide
PNH 602	370	Light Tourist— 20" wide
PNH 603	365	Allrounder— 19 $\frac{3}{4}$ " wide
PNH 604	344	Speed Track— 24 $\frac{7}{8}$ " wide
PNH 605	804	Maes— 15 $\frac{1}{2}$ " wide

When ordering please quote Sales Number

P H I L L I P S C Y C L E F I T M E N T S

HANDLEBAR STEMS

The handlebar stems illustrated on this page are manufactured from best quality steel, and are heavily chromium plated. They are made suitable for bends with $\frac{1}{6}$ " ferrules, and are supplied complete with expander bolts.

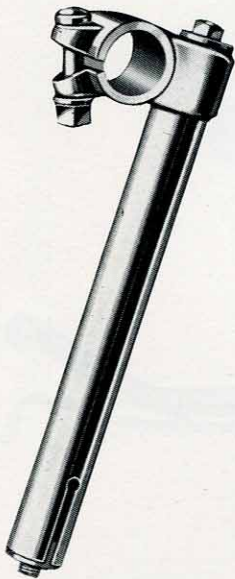

PNJ 801
PNJ 802



PNJ 803

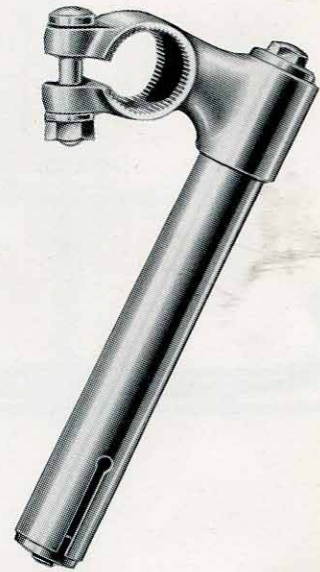

PNJ 804

Sales No.	Former List No.	Description
PNJ 801	276	6" stem with 1 $\frac{1}{4}$ " extension
PNJ 802	"	7" " " 2 $\frac{1}{2}$ " "
PNJ 803	311	7 $\frac{1}{2}$ " " " 1 $\frac{3}{4}$ " "
PNJ 804	379	" " " 1 $\frac{3}{4}$ " "

When ordering please quote Sales Number

P H I L L I P S C Y C L E F I T M E N T S

HANDLEBARS WITH TOP PARTS

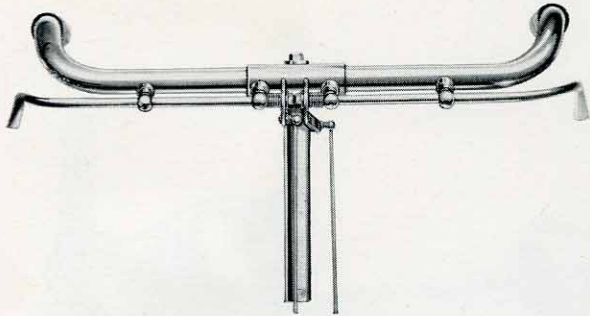

PNA 501

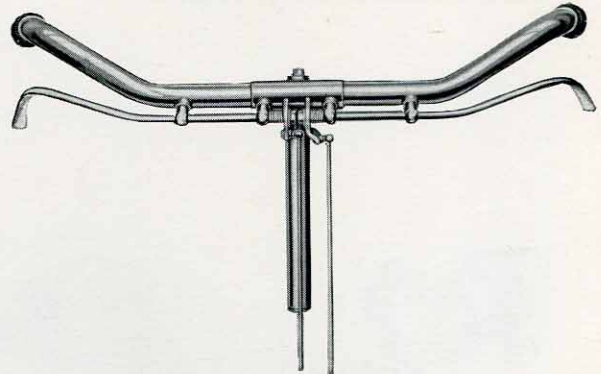

PNA 502

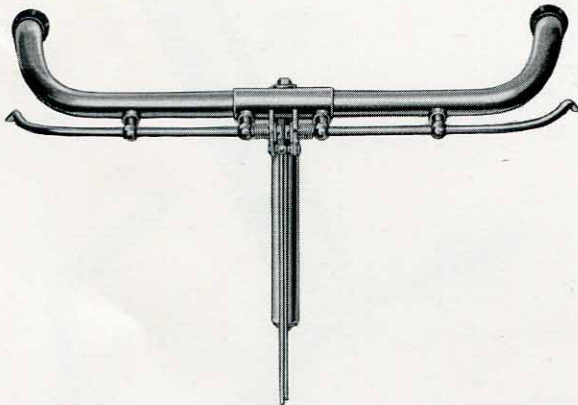

PNA 506

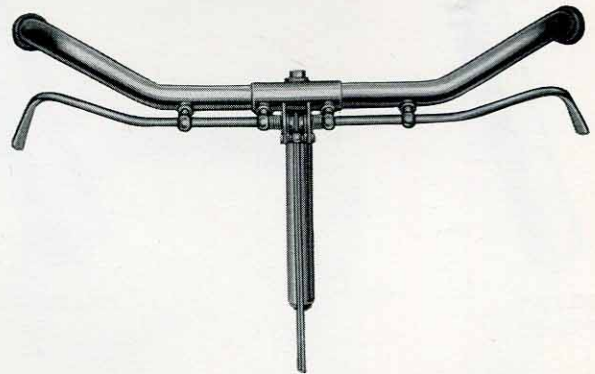

PNA 623

Sales No.	Description
PNA 501	Celtonia Ordinary Raised with double brake top parts and grips
PNA 502	Celtonia North Road Raised with double brake top parts and grips
PNA 506	Yoke and Hinge Ordinary Raised with double brake top parts and grips
PNA 623	Yoke and Hinge North Road Raised with double brake top parts and grips

All models are fitted with expander bolts and grips and are heavily chromium plated. The brake bottom parts suitable for these handlebars and top parts are as illustrated on page 22.

When ordering please quote Sales Number

PHILLIPS CYCLE FITMENTS

HANDLEBARS WITH TOP PARTS

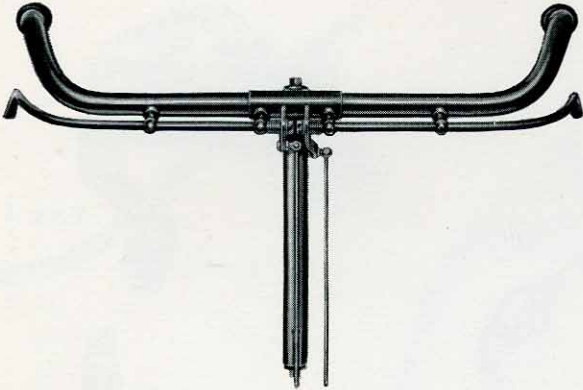

PNA 505

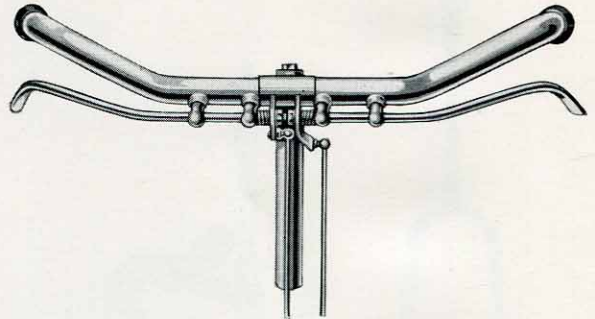

PNA 503

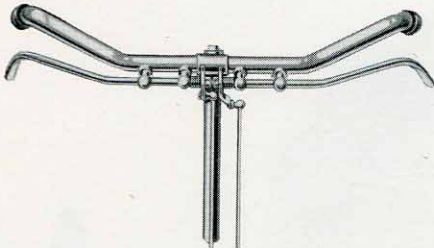

PNA 504

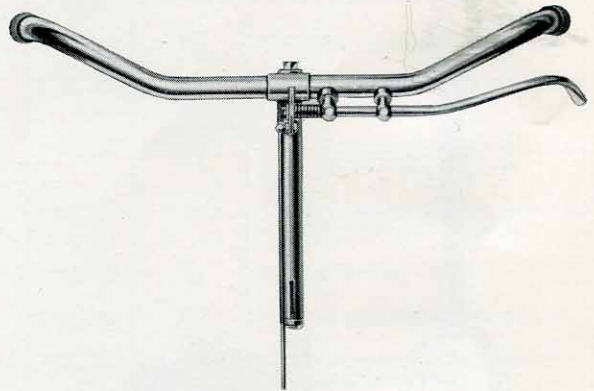

PNA 510

Sales No.	Description
PNA 503	Juvenile North Road Raised with double brake top parts and grips
PNA 504	Kiddies North Road Raised with double brake top parts and grips $\frac{3}{4}$ " dia. tubing
PNA 505	Carrier Ordinary Raised with double brake top parts and grips (Black enamelled)
PNA 510	Kiddies North Road Raised with front brake top parts only and grips $\frac{3}{4}$ " dia. tubing

All models are fitted with expander bolts and grips and are heavily chromium plated, except Carrier model PNA 505, which is finished in black enamel.

When ordering please quote Sales Number

PHILLIPS CYCLE FITMENTS

BRAKE BOTTOM PARTS

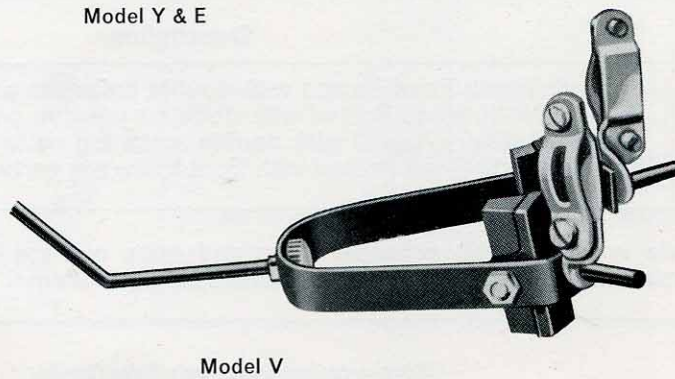
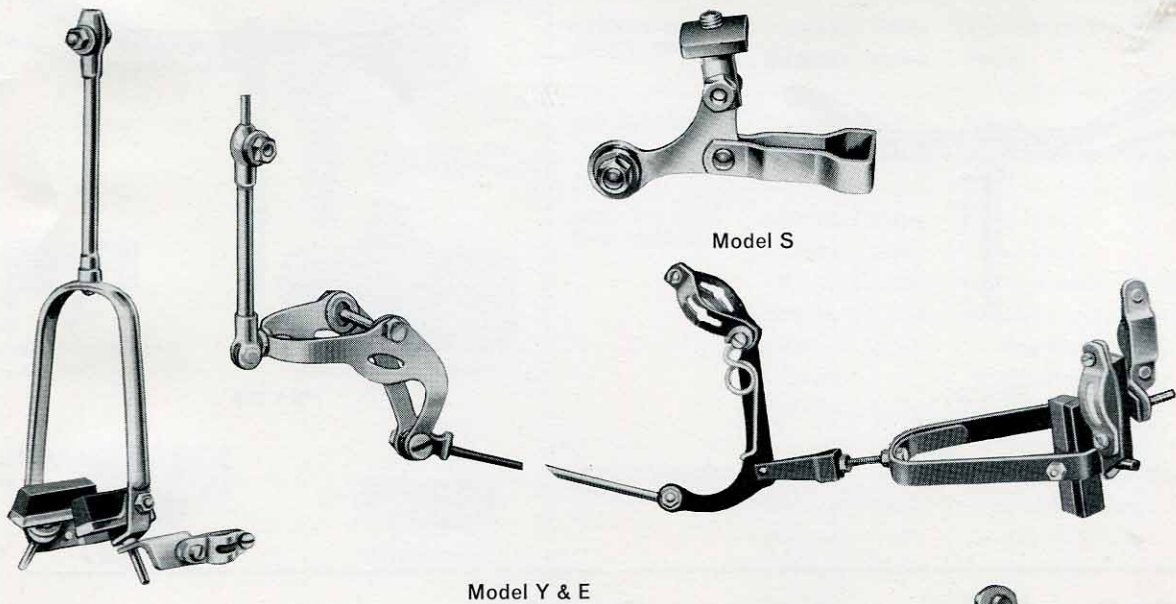
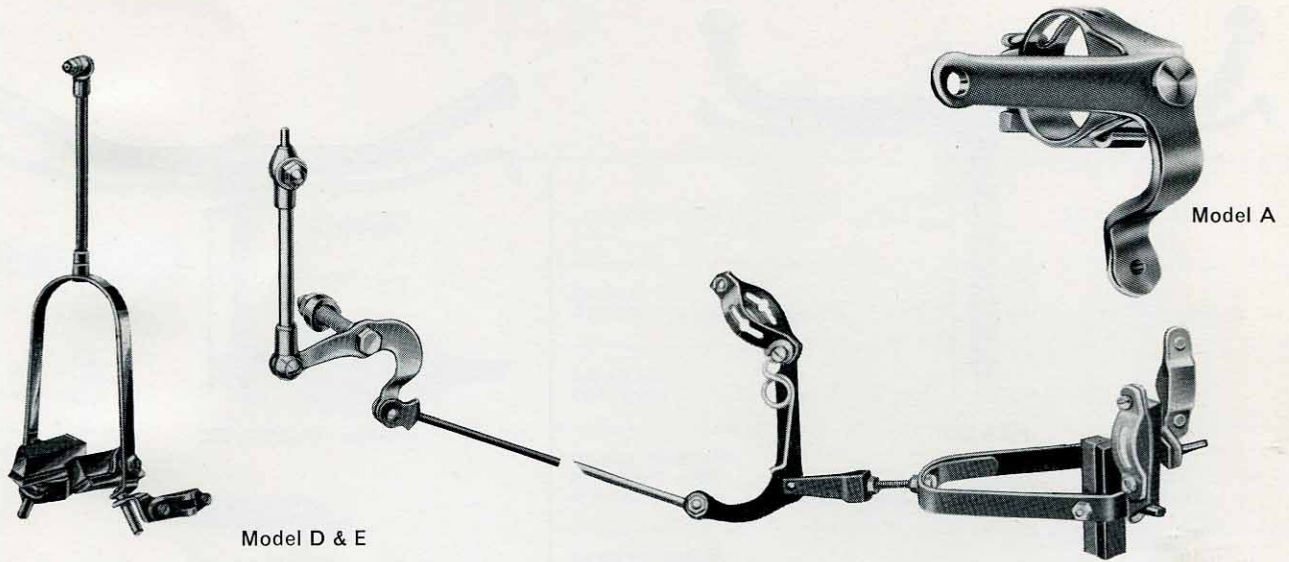

When ordering please quote Sales Number

P H I L L I P S C Y C L E F I T M E N T S

BRAKE BOTTOM PARTS

The Brake Bottom Parts illustrated on this page are as supplied with the handlebars and top parts illustrated on page 20 and 21.

	Sales No.	Type	Head Size	Finish
MODEL D & E (Bolt fitting at bottom head lug, and clip fitting at bottom bracket)	PJE 805	Juvenile	5"	Black and Chromium
	PJE 806	"	"	" " " 1" Seat tube clip
	PJE 815	Standard	"	" " "
	PJE 816	"	6"	" " "
	PJE 817	"	8"	" " "
	PJE 818	"	5"	All Chromium "
	PJE 819	"	6"	" "
	PJE 820	"	8"	" "
	PJE 821	Carrier	6"	All Black "
	PJE 822	"	8"	" "
	PJE 823	"	14"	" "
	PJE 807	"	14"	" " Balloon stirrups
	PJE 808	"	6"	" " "
MODEL A & E (Clip fitting at bottom head lug and bottom bracket)	PJE 801	Standard	6"	Black and Chromium
	PJE 802	"	8"	" " "
MODEL D & S (Bolt fitting at bottom head lug and bottom bracket)	PJE 830	Junior	5"	Black and Chromium
	PJE 831	"	6"	" " "
	PJE 832	"	7"	" " "
	PJE 833	"	5"	All Chromium "
	PJE 834	"	6"	" "
	PJE 835	"	7"	" "
	PJE 809	Standard	5"	Black and Chromium
	PJE 810	"	6"	" " "
	PJE 811	"	8"	" " "
	PJE 812	"	5"	All Chromium "
	PJE 813	"	6"	" "
PJE 814	"	8"	" "	
MODEL Y & E (Yoke type double bellcrank lever fitting at bottom head lug and clip fitting at bottom bracket)	PJE 803	Standard	6"	Black and Chromium
	PJE 804	"	8"	" " "
MODEL D & V (Bolt fitting at bottom head lug and direct transmission to the rear stirrup)	PJE 824	Junior	5"	Black and Chromium
	PJE 825	"	6"	" " "
	PJE 826	"	7"	" " "
	PJE 827	"	5"	All Chromium "
	PJE 828	"	6"	" "
	PJE 829	"	7"	" "

The term "black and chromium" denotes that the rear brake parts, from bellcrank lever downwards, are black enamel and that the remaining parts are chromium plated.

FRONT BRAKE BOTTOM PARTS ONLY

Sales No.	Type	Head Size	Finish
PJB 801	Junior	4"	All Chromium
PJB 802	"	5"	" "
PJB 803	"	6"	" "
PJB 804	"	7"	" "
PJB 808	Standard	5"	" "
PJB 809	"	6"	" "
PJB 810	"	8"	" "
PJB 805	Carrier	6"	All Black
PJB 806	"	8"	" "
PJB 807	"	14"	" "

When ordering please quote Sales Number

P H I L L I P S C Y C L E F I T M E N T S

SPARE PARTS FOR BRAKE TOP PARTS

	DESCRIPTION	SALES No.	FORMER LIST No.	SUITABLE FOR:
<p style="text-align: center;">Lever Unit</p> <p style="text-align: center;">Screw-in Stud Unit</p> <p style="text-align: center;">Spring</p> <p style="text-align: center;">Plunger Arm Rear</p> <p style="text-align: center;">Plunger Arm Front</p> <p style="writing-mode: vertical-rl; transform: rotate(180deg);">Plunger Rod and Arm, Rear</p> <p style="writing-mode: vertical-rl; transform: rotate(180deg);">Plunger Rod and Arm, Front</p> <p style="writing-mode: vertical-rl; transform: rotate(180deg);">Plunger Rod</p> <p style="writing-mode: vertical-rl; transform: rotate(180deg);">Plunger Rod and Swivel</p>	LEVER UNIT	PNB 109 PNB 110 PNB 111 PNB 112 PNB 801	B 1112x B 1112x B 1101x B 1101x B 1115x	North Road Raised, R.H. " " " " L.H. Ordinary " Raised", R.H. " " " " L.H. Juvenile & Kiddies N.R.R. R.H. Juvenile & Kiddies N.R.R. L.H. Carrier (Black) R.H. " " " " L.H.
	PLUNGER ROD and ARM, FRONT	PND 801 PND 803 PND 805 PND 807	B 1001x B 1011x B 1001C B 1011xL	Standard Kiddies and Juvenile Carrier Yoke and Hinge
	PLUNGER ROD and ARM, REAR	PND 802 PND 804 PND 806 PND 808	B 1002x B 1022x B 1002C B 1012xR	Standard Kiddies and Juvenile Carrier Yoke and Hinge
	PLUNGER ROD and SWIVEL	PNM 802 PNM 803	B 1301R B 1301S	With rivet With screw
	PLUNGER ROD	PNM 804	B 1301	All Models
	PLUNGER ARM, FRONT	PNM 805 PNM 807 PNM 809	B 1001 B 1011 B 1011 L	Standard Kiddies Yoke and Hinge
	PLUNGER ARM, REAR	PNM 806 PNM 808 PNM 810	B 1002 B 1022 B 1012 R	Standard Kiddies Yoke and Hinge
	SCREW-IN STUD UNIT	PMP 119 PMP 120 PMP 207	B 1801 B B 1801 L B 1801 K	(Outer) All except Kiddies (Inner) " " "
	SPRING	PNM 115 PNM 116	Q 101 Q 102	R.H. All Models L.H. All Models















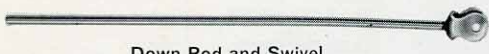

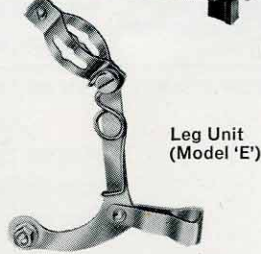

SPARE PARTS FOR REAR BRAKE FULCRUMS

	DESCRIPTION	SALES No.	FORMER LIST No.	SUITABLE FOR:
<p style="text-align: center;">Tube Unit</p> <p style="text-align: center;">Tube only</p> <p style="text-align: center;">Top Joint Top Joint Pin, Nut and Washer Swivel Joint Swivel Joint Pin</p> <p style="text-align: center;">Bell Crank Lever Unit (Yoke and Hinge) Bell Crank Lever Unit (Standard)</p>	TUBE UNITS	PJA 808 PJA 809 PJA 810 PJA 811 PJA 823 PJA 824 PJA 825	B 301 R B 301 R B 301 R B 301 R B 302 R B 302 R B 302 R	3½" 2½" 4½" 5½" 3½" Carrier 4½" " 11½" "
	TUBE ONLY	PJA 801 PJA 802 PJA 803 PJA 804 PJA 805 PJA 806 PJA 807 PJA 812 PJA 813 PJA 814	B 301 B 301 B 301 B 301 B 302 B 302 B 302 B 302 B 302 B 302	2½" 3½" 4½" 5½" 3½" Carrier 4½" " 11½" " 6½" 5½" Carrier 6½" "
	TOP JOINT	PJM 801 PJM 803	B 401 B 405	All Models except Carrier Carrier
	TOP JOINT PIN, NUT & WASHER	PMP 116 PMP 206	B 501x B 502x	All Models except Carrier Carrier
	SWIVEL JOINT	PJM 802 PJM 804	B 703 B 712	All Models except Carrier and Yoke and Hinge Carrier
	SWIVEL JOINT PIN	PMB 120 PMB 323	S 606 S 626	All Models except Carrier Carrier
	BELLCRANK LEVER UNIT	PJT 109 PJT 807 PJT 804	B 1006x B 1023x B 1007x	All except Kiddies and Yoke and Hinge Kiddies Yoke and Hinge

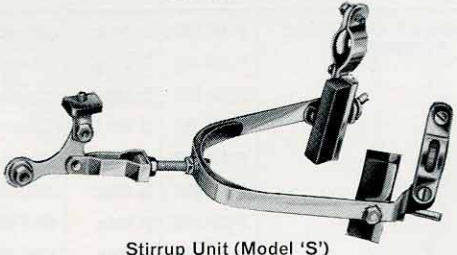
When ordering please quote Sales Number

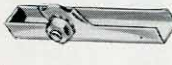
P H I L L I P S C Y C L E F I T M E N T S









SPARE PARTS FOR REAR BRAKE FULCRUMS (CONT'D.)

	DESCRIPTION	SALES No.	FORMER LIST No.	SUITABLE FOR:	
 Bell Crank and Bolt Unit	 Bell Crank	PJT 110	B 1006	All except Kiddies and Yoke and Hinge Yoke and Hinge Kiddies	
		PJT 808 PJT 809	B 1007 A B 1023		
 Bell Crank Lever Unit (Clip Pattern)		PMP 127	S 804x	All except Kiddies and Yoke and Hinge Kiddies Yoke and Hinge Carrier—Enamel L.G. Carrier—Enamel	
		PMP 197 PMP 198 PMP 195 PMP 196	S 817x S 610x S 804x S 804x		
 Pivot Bush Unit		PJT 108	B 1605x		
		PJL 111 PJL 802 PJL 801 PJL 803	B 1302x B 1302x B 1313x B 1313x		
 Down Rod and Swivel		PMP 117	S 811x		
 Seat Tube Clip	 Stirrur Unit (Model 'E')	PJK 803 PJK 804 PJK 801 PJK 802 PJK 805	B 101 E B 101 E B 106 E B 106 E B 105 E	Standard (Enamel) (Plated) Juvenile (1 1/8" Clip) (1" Clip) Carrier (Balloon)	
 Leg Spring	 Leg Unit (Model 'E')	PJT 104 PJT 801	B 1005x B 1005 K	All except Juvenile Juvenile (1" Clip)	
 Stud Unit Bracket Bottom		PJT 105 PJT 802	B 1610x B 1642x	Standard 1 1/8" Juvenile 1"	
		PJM 101	Q 608	All Models	
		PJK 808 PJK 809 PJK 806 PJK 807 PJK 810 PJK 811	B 101 S B 101 S B 106 S B 106 S	Standard (Enamel) (Plated) Junior (Enamel) (Plated) Model 'V' (Enamel) (Plated)	
 Rear Stirrup only		PJK 854 PJK 855 PJK 856	B 101 B 106 B 105	Standard Junior and Juvenile Low Gravity Carrier	
 Leg Unit (Model 'S')	 Stirrur Unit (Model 'S')	PJT 106 PJT 803	B 1009x B 1010x	All except Kiddies and Yoke and Hinge Kiddies	
		PJT 107	B 1404x	All Models	
		PMP 118 PMP 193	S 608x S 607x	Standard Juvenile	
		PJP 105 PJP 106 PJP 801 PJP 802 PJP 803 PJP 804	B 202x B 202x B 201 F B 201 F B 205x B 205x	Standard L.H. Standard R.H. Carrier L.H. Carrier R.H. Kiddies L.H. Kiddies R.H.	
		PKS 803 PJS 101	B 601 B 609	Wide Standard Standard	
		PJR 101 PJR 102 PJR 801 PJR 802 PJR 803 PJR 804	B 202 S B 202 S B 201 C B 201 C B 205 S B 205 S	Standard L.H. Standard R.H. Carrier R.H. Carrier L.H. Kiddies R.H. Kiddies L.H.	
 Brake Shoe & Rubber	 Rubber only	 Brake Shoe with Pin Nut and Washer	PMP 115 PMP 192	S 632x S 611x	All Models except Carrier Carrier
			PJN 801 PJN 802 PJN 803 PJN 804 PJN 805	B 1603x B 1603x B 1614x B 1616x B 1624x	Standard 3/8" 'D' (Enamel) " " " " (Chrome) " " " " " " Round " Kiddies (Chrome) " Standard 3/8" Round (Chrome) Standard 3/8" 'D' (Chrome) Yoke and Hinge (Chrome)
 Fork Clip and Pins	 Connection Screw Unit	 Shoe Pin Nut & Washer	PJN 806 PJN 807	B 1625x B 1629x	

When ordering please quote Sales Number

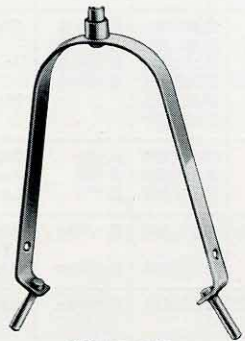
PHILLIPS CYCLE FITMENTS

SPARE PARTS FOR FRONT BRAKES

	DESCRIPTION	SALES No.	FORMER LIST No.	SUITABLE FOR:
 Tube with Top Joint  Tube only	TUBE WITH TOP JOINT	PJA 815 PJA 816 PJA 817 PJA 818 PJA 819 PJA 820 PJA 821 PJA 822	B 301 F B 301 F B 301 F B 301 F B 301 F B 302 F B 302 F B 302 F	2½" 3½" 4½" 5½" 6½" 4½" Carrier 5½" " 12½" "
 Top Joint  Top Joint Pin Nut and Washer	TUBE ONLY	PJA 801 PJA 802 PJA 803 PJA 804 PJA 805 PJA 806 PJA 807	B 301 B 301 B 301 B 301 B 302 B 302 B 302	2½" 3½" 4½" 5½" 3½" Carrier 4½" " 11½" "
	TOP JOINT ONLY	PJM 801 PJM 803	B 401 B 405	All Models except Carrier Carrier
	TOP JOINT PIN NUT & WASHER	PMP 116 PMP 206	B 501x B 502x	All Models except Carrier Carrier
 Stirrup only	STIRRUP ONLY	PJK 850 PJK 853 PJK 851 PJK 852	B 101 F B 116 F B 105 F	All Standard Models (including Juvenile and Junior) Yoke and Hinge Carrier (Standard) Equal Wheel and Low Gravity Carriers
 Brake Shoe and Rubber  Rubber only	BRAKE SHOE and RUBBER	PJP 105 PJP 106 PJP 801 PJP 802 PJP 803 PJP 804 PJP 807 PJP 808	B 202x B 202x B 201 F B 201 F B 205x B 205x B 201x B 201x	Standard L.H. Standard R.H. Carrier L.H. Carrier R.H. Kiddies L.H. Kiddies R.H. Old Wide Pattern L.H. Old Wide Pattern R.H.
	BRAKE RUBBER ONLY	PJS 101 PJS 802 PKS 803	B 609 B 603 B 601	Narrow Carrier Wide
 Brake Shoe with Pin, Nut and Washer  Shoe Pin Nut and Washer	BRAKE SHOE WITH PIN, NUT and WASHER	PJR 101 PJR 102 PJR 801 PJR 802 PJR 803 PJR 804	B 202 S B 202 S B 201 C B 201 C B 205 S B 205 S	Standard L.H. Standard R.H. Carrier R.H. Carrier L.H. Kiddies R.H. Kiddies L.H.
	SHOE PIN, NUT and WASHER	PMP 115 PMP 192	S 632x S 611x	All Models except Carrier Carrier

When ordering please quote Sales Number

PHILLIPS CYCLE FITMENTS

CHAIN WHEELS AND CRANKS



FLAT

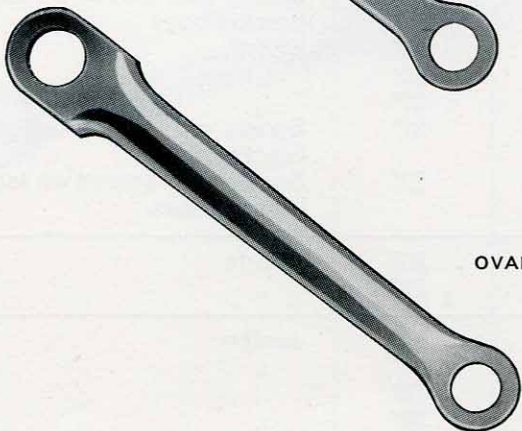

OVAL

Sales No.	Former List No.	Description
Chainwheels and Cranks complete		
PBR 601		28T × 4½" Oval Cranks
PBR 602	F 1011o	28T × 4" " "
PBR 603	F 1027o	32T × 4½" " "
PBR 604	F 1036o	40T × 5½" " "
PBR 605	F 1036o	44T × 6½" Popular Square Crank
PBR 606	F 1036o	46T × 6½" " " "
PBR 607	F 1036o	48T × 6½" " " "
PBR 608	F 1036o	48T × 7" " " "
PBR 611		46T × 6½" Popular Square Crank (Black, Carrier ½" × ⅜")
Chainwheels and Right-Hand Cranks only		
PBN 601		28T × 4½" Oval Crank
PBN 602	F 1011x	28T × 4" " "
PBN 603	F 1027x	32T × 4½" " "
PBN 604	F 1036x	40T × 5½" " "
PBN 605	F 1036x	44T × 6½" Popular Square Crank
PBN 606	F 1036x	46T × 6½" " " "
PBN 607	F 1036x	48T × 6½" " " "
PBN 608	F 1036x	48T × 7" " " "
PBN 611	F 1036x	46T × 6½" Popular Square Crank (Black Carrier ½" × ⅜")
Left-Hand Cranks		
PBP 801	F 1028	4½" Oval Crank
PBP 802	F 1012	4" " "
PBP 803	F 1037	5½" " "
PBP 804	F 1037	6½" Popular Square Crank
PBP 805	F 1037	7" " " "
PBP 806	F 1008	6½" " " " (Black)

When ordering please quote Sales Number

P H I L L I P S G Y C L E F I T M E N T S

FORKS



PAB 801



PAB 808



PAB 817



PAB 819

Sales No.	Former List No.	Column Length above Crown	Threading	For Wheel Size	Description
PAB 801	211	11"	3"	28"	Roadster
PAB 802	211	9"	3"	28"	"
PAB 803	211	7"	3"	28"	"
PAB 804	211	9"	3"	26"	"
PAB 805	211	7"	3"	26"	"
PAB 806	211	9"	3"	24"	"
PAB 807	211	7"	3"	24"	"
PAB 808	212	9"	3"	24"	Sports
PAB 809	212	7"	3"	24"	"
PAB 810	212	9"	3"	26"	Sports with brazed on lamp bracket boss
PAB 811	212	7"	3"	26"	Sports with brazed on lamp bracket boss
PAB 812	212	9"	3"	26"	Sports
PAB 813	212	7"	3"	26"	"
PAB 814	212	7"	3"	27"	"
PAB 815	212 A	7"	3"	27"	Sports with brazed on lamp bracket boss
PAB 816	212 A	9"	3"	27"	Sports with brazed on lamp bracket boss
PAB 817	273	9"	3"	26"	Sports
PAB 818	273	7"	3"	26"	"
PAB 819	266	8"	2"	14"	Junior
PAB 820	266	8"	2"	16"	"
PAB 821	266	8"	2"	18"	"
PAB 822	266	8"	2"	20"	"

All Phillips replacement forks are constructed from high grade materials and are fitted with crown races.

When ordering please quote Sales Number

P H I L L I P S C Y C L E F I T M E N T S



209

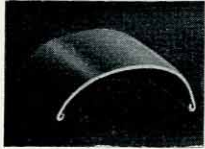

259



492

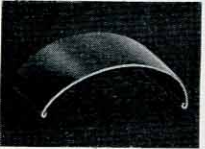

494 and 495



623

Sales No. (pair)	Former List No.	Wheel Size	Finish	Lining	Description
PDA 501	209	28"	Black	Red Gold	Roadster deep section
"	"	"	Bright Red	Double Gold	" " "
"	"	"	Raleigh Green	" "	" " "
"	"	"	Royal Blue	" "	" " "
PDA 502	"	26"	Black	Red Gold	" " "
PDA 503	"	24"	"	" "	" " "
PDA 504	259	26"	Black	Double Green	Roadster Wide Section
PDA 505	492	28"	Black	Red Gold	Roadster Special Deep Section
"	"	"	Bright Red	Double Gold	" " " "
"	"	"	Raleigh Green	" "	" " " "
"	"	"	Royal Blue	" "	" " " "
PDA 506	"	26"	Black	Red Gold	" " " "
PDA 507	"	24"	"	" "	" " " "
PDA 508	494	26"	Black	None	Carrier section, Enamel stays
PDA 509	495	20/26"	"	"	Low gravity carrier section, Enamel stays
PDA 510	623	26"	Black with C.P. Peak	Red Gold	Sports Wide Pattern
"	"	"	White with C.P. Peak	Single Gold	" " "
"	"	"	Chrome Plated	None	" " "
PDA 512	"	24"	Black with C.P. Peak	Red Gold	" " "
PDA 514	"	"	Chrome Plated	None	" " "
PDA 513	"	20"	Black with C.P. Peak	Red Gold	" " "
PDA 515	"	"	Chrome Plated	None	" " "

NOTE:—

Mudguards

The above mudguards can be supplied in other colours, for orders of a minimum quantity of 100 pairs, of one size, type and finish.

When ordering mudguards please state (1) Sales No. (2) Colour (3) Lining required

**CHAINGUARDS
Complete with Fittings**



Sales No.	Former List No.	Description
PCA 601	606	For 24" Wheel and with $\frac{3}{8}$ " O clips
PCA 602	607	" 20" " " " $\frac{3}{8}$ " D "
PCA 603	604	" 26" " " " $\frac{3}{8}$ " O "
PCA 604	605	" 24" " " " $\frac{3}{8}$ " D "
PCA 605	602	" 26" " " " $\frac{3}{8}$ " D "
PCA 606	"	" " " " " " " "
PCA 607	601	" 28" " " " $\frac{5}{8}$ " D clips (Chromium plated)

The above chain-guards (except PCA 606) are supplied in Black Enamel finish, lined Red/Gold, with Phillips Transfer, but they can be supplied in other colours, for orders of a minimum quantity of 100, of one size and finish.

**MUDGUARD STAYS
Complete with Fittings**

Sales No. (Set)	Suitable For
PDJ 801	PDA 501
PDJ 802	PDA 502
PDJ 803	PDA 503
PDJ 804	PDA 510, PDA 511
PDJ 805	PDA 512, PDA 514
PDJ 806	PDA 513, PDA 515
PDJ 807	PDA 504
PDJ 808	PDA 508
PDJ 809	PDA 509
PDJ 810	PDA 505
PDJ 811	PDA 506
PDJ 812	PDA 507

PHILLIPS CYCLE OIL

Sales No.	Former List No.	Description
PMA 501	M 1604X	Phillips cycle lubricating oil in square tin. 8 oz. capacity

When ordering please quote Sales Number

PHILLIPS CYCLE FITMENTS

BRACKET AXLES

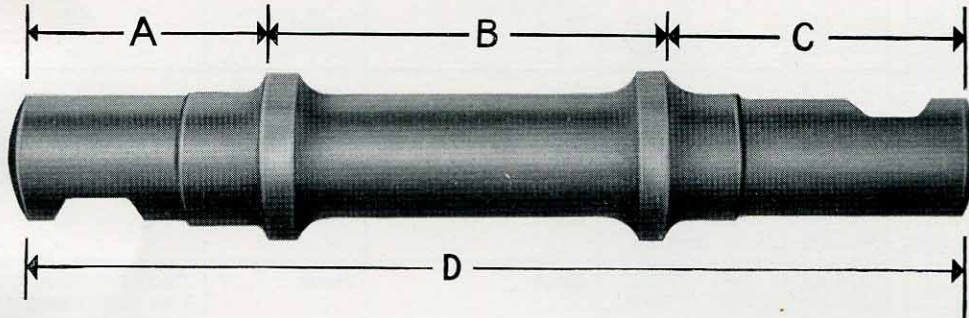

Sales No.	Former List No.	A	B	C	D	Description
PBA 502	F 101	$1\frac{21}{64}$ "	$2\frac{3}{64}$ "	$1\frac{5}{8}$ "	5"	Standard G.C.C. $1\frac{1}{2}$ " Chain Line
PBA 503	F 109	$1\frac{3}{8}$ "	$2\frac{3}{64}$ "	$1\frac{49}{64}$ "	$5\frac{3}{16}$ "	$\frac{1}{8}$ " Extra G.C.C. $1\frac{5}{8}$ " " "
PBA 504	F 113	$1\frac{5}{16}$ "	$2\frac{3}{64}$ "	$1\frac{45}{64}$ "	$5\frac{1}{16}$ "	$\frac{1}{16}$ " Extra G.C.C. $1\frac{1}{2}$ " " "
PBA 506	F 139	$1\frac{39}{64}$ "	$2\frac{3}{64}$ "	$1\frac{39}{64}$ "	$5\frac{1}{4}$ "	N.G.C.C. $1\frac{1}{2}$ " " "
PBA 508	F 104	$1\frac{7}{16}$ "	$2\frac{27}{64}$ "	$1\frac{47}{64}$ "	$5\frac{19}{32}$ "	Carrier $1\frac{3}{4}$ " " "
PBA 601	F 103	$1\frac{21}{64}$ "	$1\frac{43}{64}$ "	$1\frac{5}{8}$ "	$4\frac{5}{8}$ "	Kiddies G.C.C. $1\frac{5}{16}$ " " "
PBA 604	F 102	$1\frac{21}{64}$ "	$2\frac{3}{64}$ "	$1\frac{5}{8}$ "	$4\frac{11}{16}$ "	Standard N.G.C.C. $1\frac{1}{2}$ " " "
PBA 510	F 122	$1\frac{21}{64}$ "	$2\frac{3}{64}$ "	$1\frac{7}{16}$ "	$4\frac{13}{16}$ "	Counter sunk ends N.G.C.C. $1\frac{5}{8}$ " " "

BRACKET CUPS

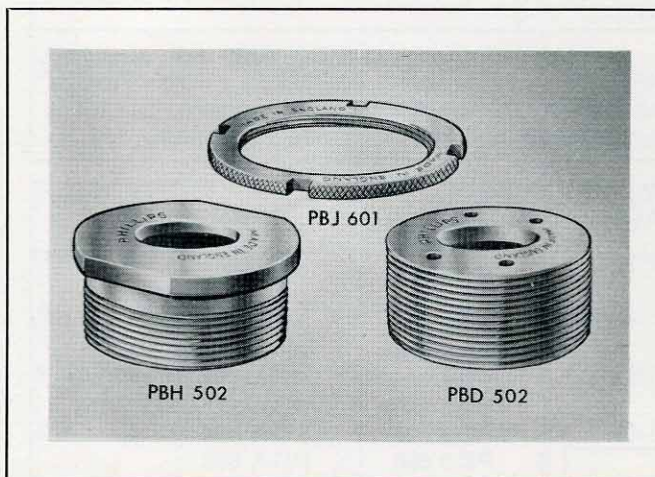

Sales No.	Former List No.	Thread		Type
		Size	Screwed	
PBD 502	F 443	24T	R.H.	Plain
PBH 502	F 444	24T	L.H.	Flanged Lock Ring
PBJ 601	F 904	—	—	Flanged Lock Ring

NOTE: That PBD 502 plain cup with 'right-hand' thread is fitted to the 'left-hand' side of bicycle, and PBH 502 flanged cup with 'left-hand' thread is fitted to 'right-hand' side of bicycle.

When ordering please quote Sales Number

PHILLIPS CYCLE FITMENTS

HEAD FITTINGS



	Standard $\frac{1}{8}$ " Ball Bearings	Carrier $\frac{5}{32}$ " Ball Bearings	Kiddies $\frac{1}{8}$ " Ball Bearings
Head Locknut	PAK 802 (N3213)	PAK 803 (N3206)	PAK 801 (N2802)
Expander Screw Race	PAL 601 (F422)	PAL 802 (F423)	PAL 801 (F410)
Top Ball Race	PAM 802 (F401)	PAM 801 (F405)	PAM 803 (F408)
Bottom Ball Race	PAM 802 (F401)	PAN 802 (F406)	PAM 803 (F408)
Crown Race	PAP 802 (F402)	PAP 803 (F407)	PAP 801 (F409)

NOTE: The former list numbers of the above Head Fittings are shown in brackets, after the Sales Number.

LAMP BRACKETS

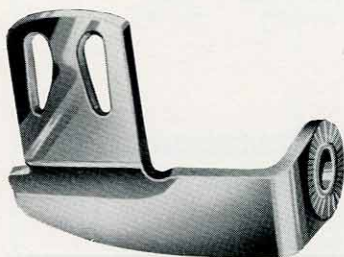

PAJ 101



PAJ 103

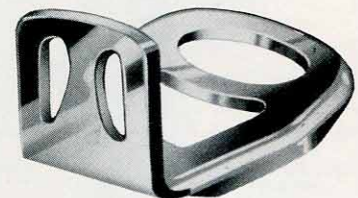

PAJ 105



PMP 201

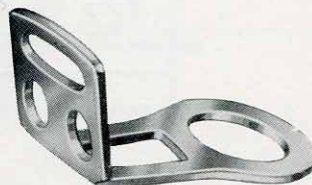

PAJ 803

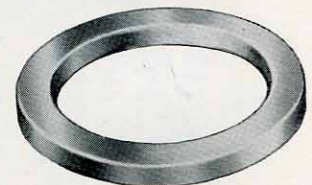

PMW 394

Sales No.	Former List No.	Description
PAJ 101 PAJ 103 PAJ 105 PAJ 803	F 1249 F 1210 F 1282 F 1204	Fork blade fitting Stem fitting Head fitting, standard Head fitting, junior
PMW 394 PMP 201	W 3202 S 1020x	Spacer ring. (Fitted in lieu of lamp bracket) Lamp bracket bolt and washer. (For PAJ 101)

When ordering please quote Sales Number

PHILLIPS CYCLE FITMENTS

MISCELLANEOUS

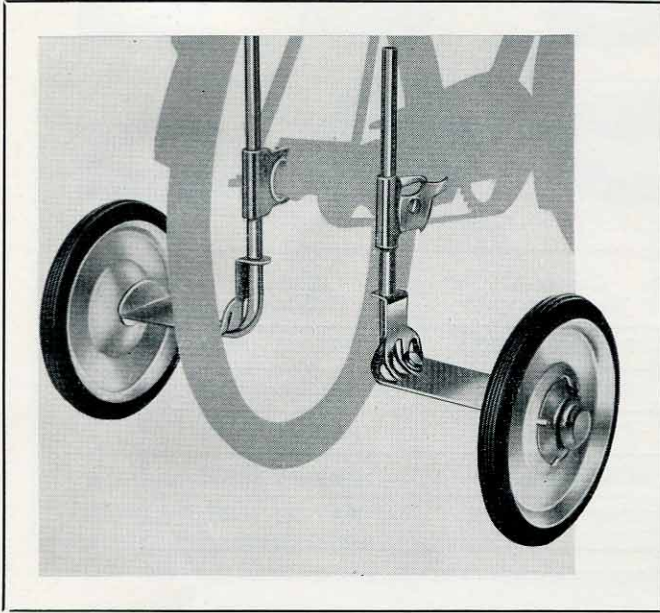

PMM 801

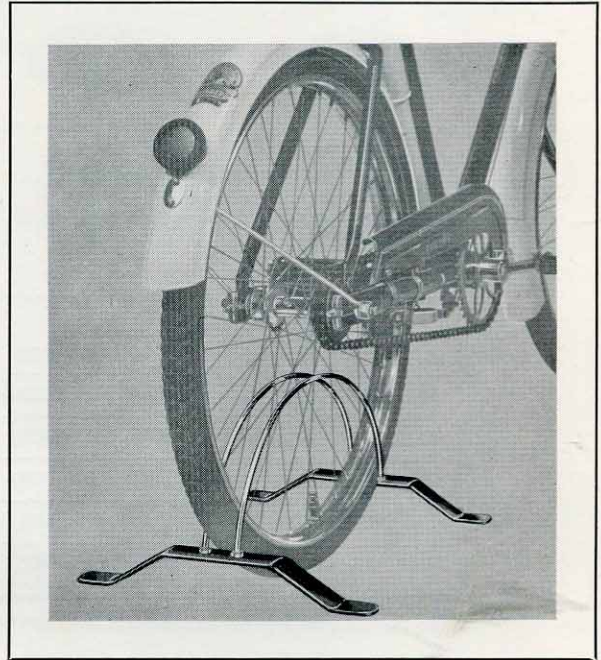

PMK 801



PMK 802

Sales No.	Former List No.	Description
PMK 801	467	Phillips Cycle Stand. (For window display, showrooms, club premises and the home. Chromium finish, with Ivory or Blue base)
PMK 802	487	Phillips Prop Stand—Suitable for sports or roadster cycles
PMM 801	594	Phillips Stabilisers. (Ideal for Kiddies learning to ride. Strongly made and easily fitted. Adjustable for 16", 18" and 20" wheels)

When ordering please quote Sales Number

PHILLIPS CYCLE FITMENTS

SEAT PILLARS

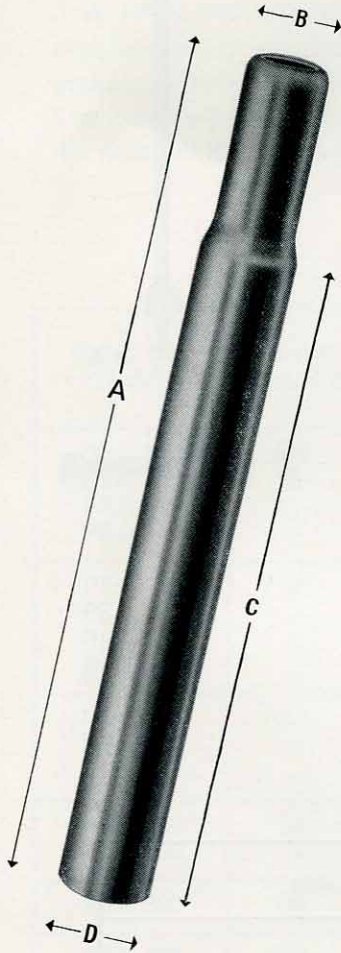

Seat Pillar

Sales No.	Former List No.	To Fit	A	B	C	D
PFS 601	F 822	1 1/8" x 18G	9"	.875"	7"	1.016"
PFS 602	F 827	1 1/8" x 18G	7"	.875"	5"	1.016"
PFS 603	F 806	1 1/8" x 20G	8 1/2"	.875"	6 1/2"	1.040"
PFS 604	F 809	1 1/8" x 20G	12"	.875"	10"	1.040"
PFS 605	F 828	1 1/8" x 20G	12"	.875"	10"	1.016"

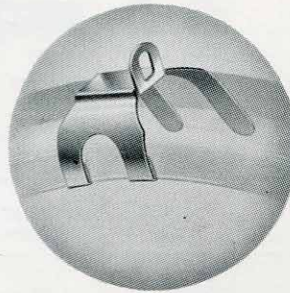

PDK 103

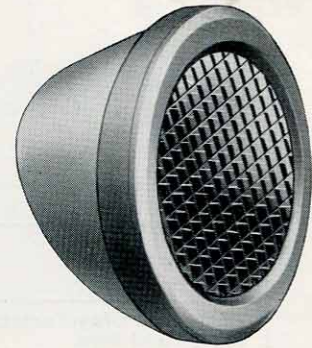

PDL 101

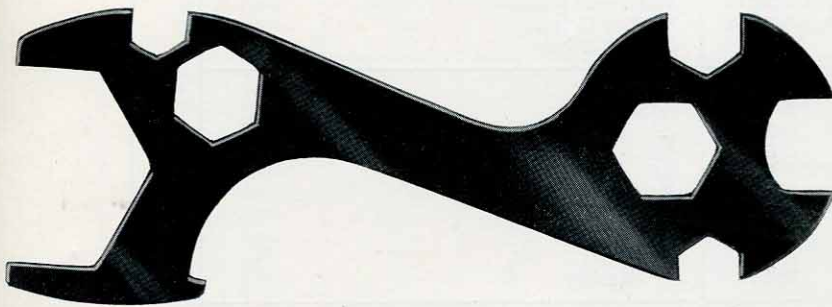

PMM 802

MISCELLANEOUS

Sales No.	Former List No.	Description
PMM 802	M714	Phillips 8-in-1 Spanner
PDK 103	L602/3x	Standard Mudguard Cleat, Suitable for Sports and Roadster Pattern Mudguards
PDL 101	480	Reflector. Grey Plastic casing. Lens conforming to British Standard 2515

When ordering please quote Sales Number

P H I L L I P S C Y C L E F I T M E N T S

MISCELLANEOUS

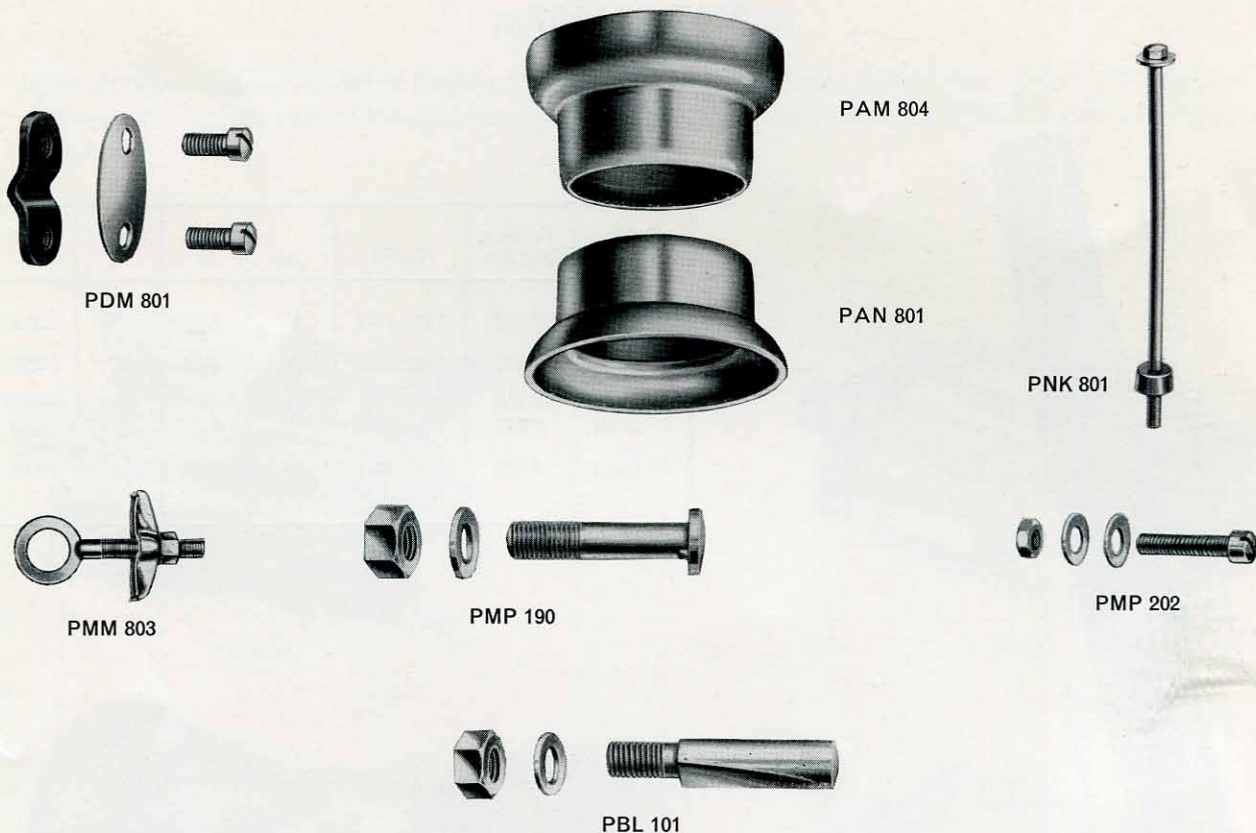

	Sales No.	Former List No.	Description
Mudguard Stay Fastening Plates and Pins	PDM 801	L 301x	Standard Pattern
Loose Race Seatings	PAN 801 PAM 804	F 414 F 424	Bottom Top
Expander Bolts Complete with plugs and washers	PNK 801 PNK 802 PNK 803 PNK 804	S 1008x S 1008x S 1008k S 1015x	For all Standard Handlebars and Stems 6½" For all Standard Handlebars and Stems 8" For Kiddies Handlebars 6½" For Carrier Handlebars 9½"
Seat Pins, Nuts and Washers	PMP 190 PMP 191 PMP 189	S 1017x S 1018x S 1004x	Standard 1½" pin Kiddies 1⅛" pin Balloon 2" pin
Pins, Nuts and Washers	PMP 202 PMP 203 PMP 204 PMP 205 PMB 105 PMB 133 PMB 325 PMB 326 PMN 103 PMW 402	S 601x S 603x S 604x S 613x S 601 S 603 S 604 S 613 N 601 W 605	$\frac{3}{16}'' \times \frac{7}{16}''$ $\frac{3}{16}'' \times \frac{1}{2}''$ $\frac{3}{16}'' \times \frac{3}{8}''$ $\frac{3}{16}'' \times 1''$ $\frac{3}{16}'' \times \frac{7}{16}''$ Pin only $\frac{3}{16}'' \times \frac{1}{2}''$ " " $\frac{3}{16}'' \times \frac{5}{8}''$ " " $\frac{3}{16}'' \times 1''$ " " $\frac{3}{16}''$ Nut $\frac{3}{16}''$ Washer
Chain Adjusters (Pair)	PMM 803	M 901x	Standard Roadster Pattern
Crank Cotter Pin, Nut and Washer	PBL 101	F 501x	Standard for all Models. Bright Plated

When ordering please quote Sales Number

PHILLIPS CYCLE FITMENTS

CARDED SPARES



Brake Shoes and Rubbers

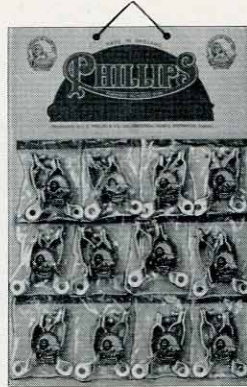

Fork Clips and Pins



Chain Adjusters

Sales No.	Former List No.	Quantity per Card	Description
PMR 501 PMR 502 PMR 503 PMR 504	B 202x B 205x C 201x C 209x	12 pairs per card 12 pairs per card 12 pairs per card 12 pairs per card	Brake Shoes and Rubbers Suitable for Standard and Juvenile Brakes Suitable for Kiddies Brakes Suitable for Vox Populi Front Cable Brakes Suitable for Vox Populi Rear Cable Brakes
PMR 505 PMR 506 PMR 507 PMR 508 PMR 509 PMR 510	B 1603x B 1614x B 1616x B 1624x B 1625x B 1603x	12 pairs per card 12 pairs per card 12 pairs per card 12 pairs per card 12 pairs per card 12 pairs per card	Fork Clips and Pins Suitable for $\frac{7}{8}$ " 'D' Forks Enamel Suitable for $\frac{3}{8}$ " Round Forks Chrome Suitable for Kiddies Forks Chrome Suitable for $\frac{3}{8}$ " Round Forks Chrome Suitable for 'D' Forks Chrome Suitable for $\frac{17}{16}$ " 'D' Forks Chrome
PMR 511	M 901x	12 pairs per card	Chain Adjusters Suitable for Roadster and Carrier Cycles
PMR 512 PMR 513	199 198	24 per card 24 per card	Wing Nuts Suitable for $\frac{5}{16}$ " Spindles Suitable for $\frac{3}{8}$ " Spindles
PMR 514 PMR 515 PMR 516 PMR 517	H 115k H 107x H 144k H 154a	12 per card 12 per card 12 per card 12 per card	Hub Spindle Units Standard Pattern—Front Standard Pattern—Rear Sports Pattern—Front Sports Pattern—Rear
PMR 518 PMR 519 PMR 520 PMR 521 PMR 522 PMR 523 PMR 524	P 127x P 133x P 134x P 141x P 110x P 128x P 148x	6 pairs per card 6 pairs per card 6 pairs per card 6 pairs per card 6 pairs per card 6 pairs per card 6 pairs per card	Pedal Spindle Units 4" Spindle 3 $\frac{1}{2}$ " Spindle 3" Spindle 4 $\frac{1}{2}$ " Spindle 4 $\frac{1}{2}$ " Spindle 2 $\frac{5}{8}$ " Spindle 3" Spindle

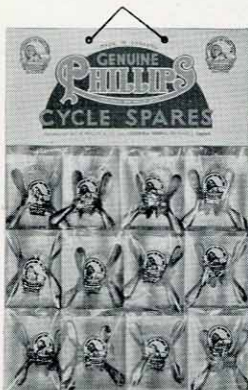

Wing Nuts

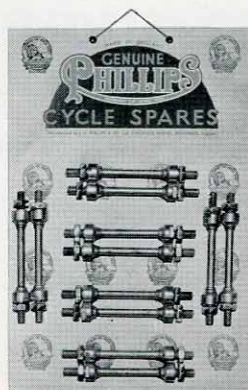

Hub Spindle Units

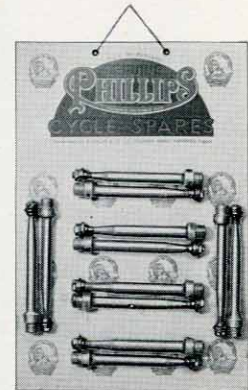

Pedal Spindle Units

When ordering please quote Sales Number

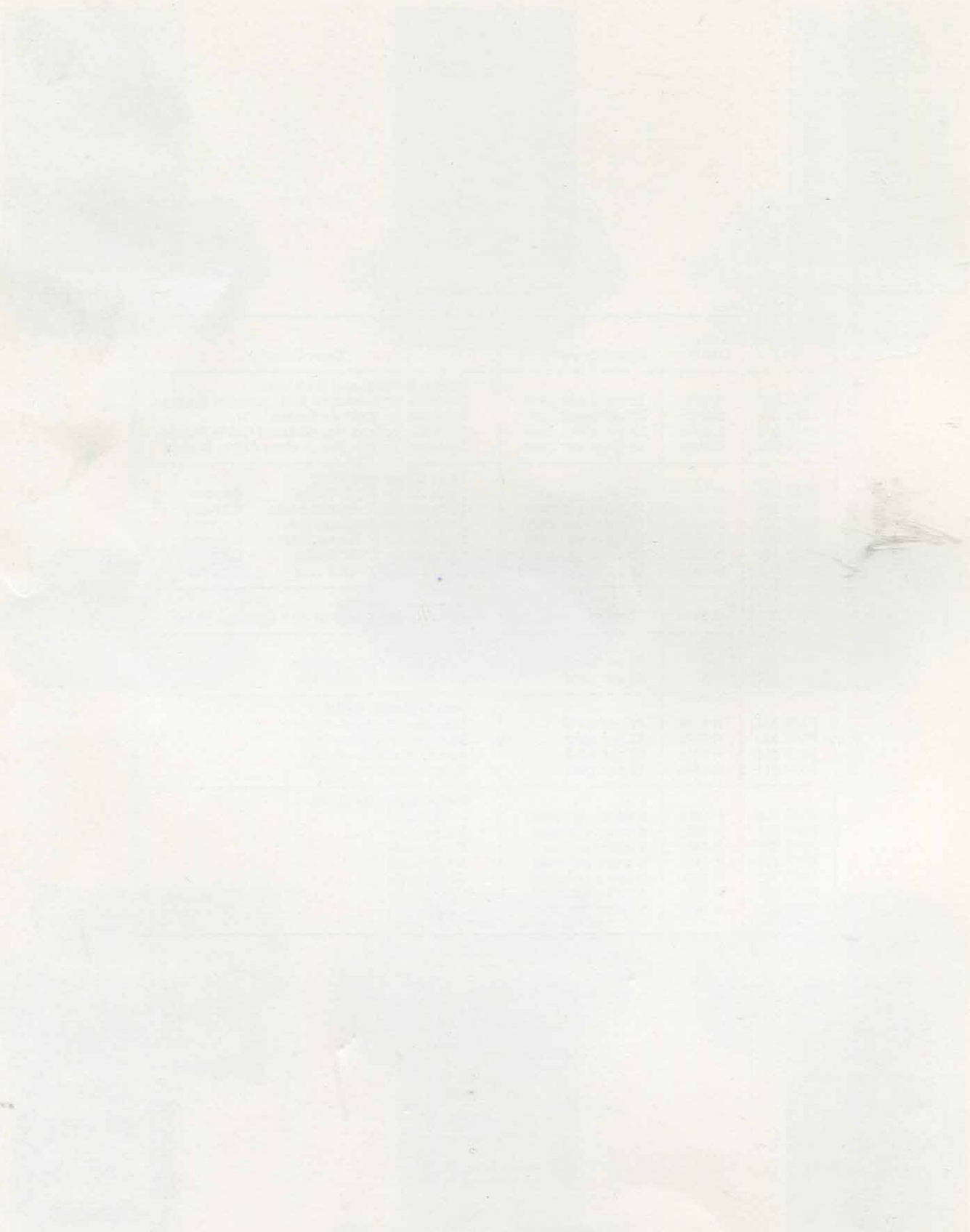

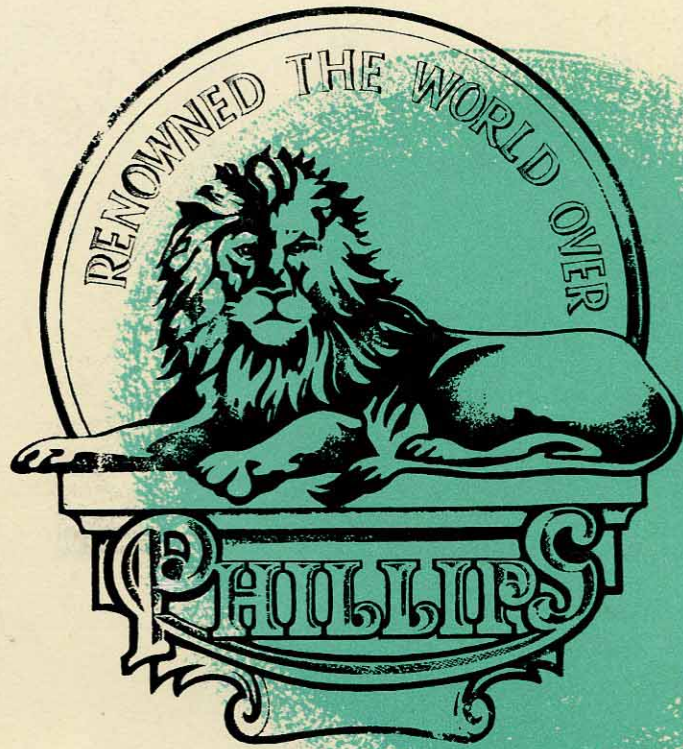

cycle fitments

IceniCAM Information Service



www.icenicam.org.uk