

# HONDA

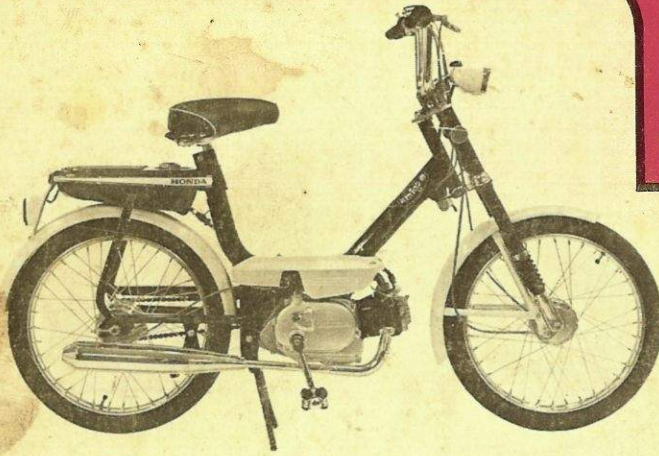

**50**

**Model PF 50**



**AMIGO**

**AMIGO - R**

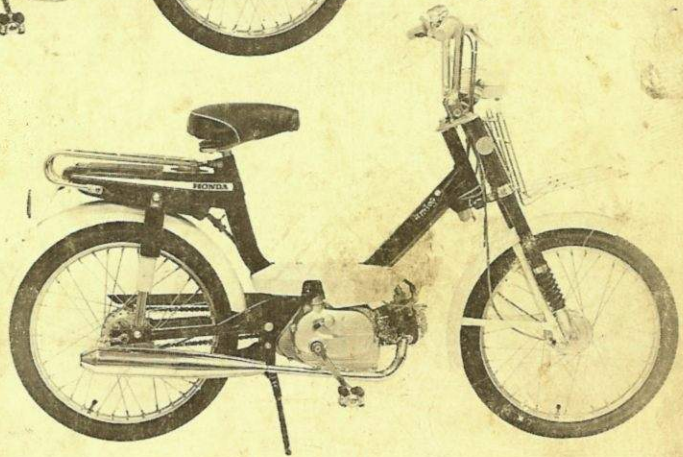

**NOVIO - R**

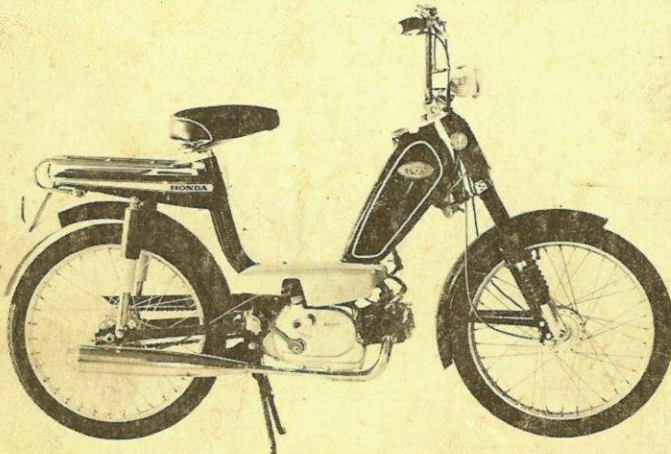

**4**

**PARTS LIST**  
**HONDA GENUINE PARTS**

**HONDA**

**Model PF 50**

**PARTS LIST**

**HONDA GENUINE PARTS**

# INSTRUKTIES VOOR HET GEBRUIK VAN DE PARTS LIST.

## 1. Samenstelling van een onderdeelnummer.

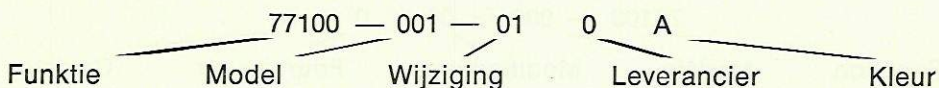

## 2. Afkortingen.

ASSY.	. . . . .	Kit
COMP.	. . . . .	Volledig
hex.	. . . . .	Hexagonaal
22 T	. . . . .	22 tanden

## 3. Afmetingen.

Alle afmetingen worden in millimeter gegeven, uitgezonderd stalen kogels en wielen.

ONDERDEEL	VOORBEELD	BESCHRIJVING
Bout	6 × 12	6 mm diameter, 12 mm lengte
Pin	8 × 14	8 mm diameter, 14 mm lengte
O-ring	9,5 × 1,6	9,5 mm diameter, 1,6 mm dikte
Oliekeerring	14 × 24 × 5	14 mm binnen diameter, 5 mm dikte 24 mm buiten diameter, 5 mm dikte
Buis	5 × 130	5 mm binnen diameter, 130 mm lengte

## 4. Toepasselijk serienummer.

Wanneer er een produktieverandering is voor een bepaald onderdeel wordt het framenummer vermeld in de kolom «Remarks» van wanneer dit onderdeel gebruikt wordt.

## 5. Onderdelen met 0 merkteken.

Deze onderdelen zijn ofwel volkomen nieuw, ofwel slechts een wijziging van vroeger geïntroduceerde onderdelen.

## 6. Code.

GB	Gebruikt in Engeland	B	Gebruikt in België
F	Gebruikt in Frankrijk	NL	Gebruikt in Nederland
DK	Gebruikt in Denemarken	I	Gebruikt in Italië

## 7. Niet afzonderlijk verkrijgbaar.

# INSTRUCTIONS POUR L'EMPLOI DU PARTS LIST.

## 1. Composition d'un numéro de pièce détachée.

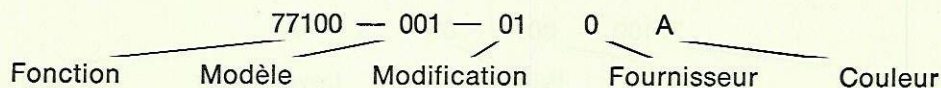

## 2. Abréviations.

ASSY.	. . . . .	Kit
COMP.	. . . . .	Complète
hex.	. . . . .	Hexagonal
22 T	. . . . .	22 dents

## 3. Dimensions.

Toutes dimensions sont données en millimètre, sauf les bielles et les jantes.

PIECE	EXEMPLE	DESCRIPTION
Ecrou	6 × 12	6 mm diamètre, 12 mm longueur
Axe	8 × 14	8 mm diamètre, 14 mm longueur
O-ring	9,5 × 1,6	9,5 mm diamètre, 1,6 mm épaisseur
Bourrage	14 × 24 × 5	14 mm diamètre intérieur 24 mm diamètre extérieur, 5 mm épaisseur
Tube	5 × 130	5 mm diamètre intérieur, 130 mm longueur

## 4. Numéro de série applicable.

Quand il y a un changement de production pour une pièce quelconque, le numéro du cadre sera mentionné dans la colonne des «Remarques», dès que cette pièce entre en série.

## 5. Pièces marquées de 0.

Il s'agit d'un changement d'une pièce introduite ultérieurement ou d'une pièce nouvelle.

## 6. Code.

GB	Utilisé en Angleterre	B	Utilisé en Belgique
F	Utilisé en France	NL	Utilisé en Hollande
DK	Utilisé en Danemark	I	Utilisé en Italie

## 7. Non livrable séparément.

# INSTRUCTIONS FOR THE USE OF PARTS LIST.

## 1. Make-up of the Part Number.

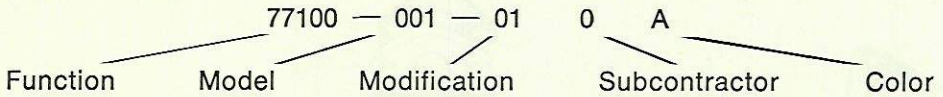

## 2. Abbreviations.

ASSY.	. . . . .	Assembly
COMP.	. . . . .	Complete
hex.	. . . . .	Hexagonal
22 T	. . . . .	22 theet

## 3. Dimensions.

All dimensions are in millimeters for steel balls and wheels.

PARTS	EXAMPLE	INTERPRETATION
Bolt	6 × 12	6 mm diameter, 12 mm length
Pin	8 × 14	8 mm diameter, 14 mm length
O-ring	9,5 × 1,6	9,5 mm diameter, 1,6 mm thickness
Oil seal	14 × 24 × 5	14 mm inside diameter 24 mm outside diameter, 5 mm thickness
Tube	5 × 130	5 mm inside diameter, 130 mm length

## 4. Applicable Serial Number

If there is a production change to a part, the frame serial number from which this part becomes effective will be indicated in the «Remarks» column.

## 5. Parts with 0 marks.

These parts are items either newly introduced or changed in this issue.

## 6. Code.

GB	Used for England	B	Used for Belgium
F	Used for France	NL	Used for Netherland
DK	Used for Denmark	I	Used for Italy

## 7. Not available separately.

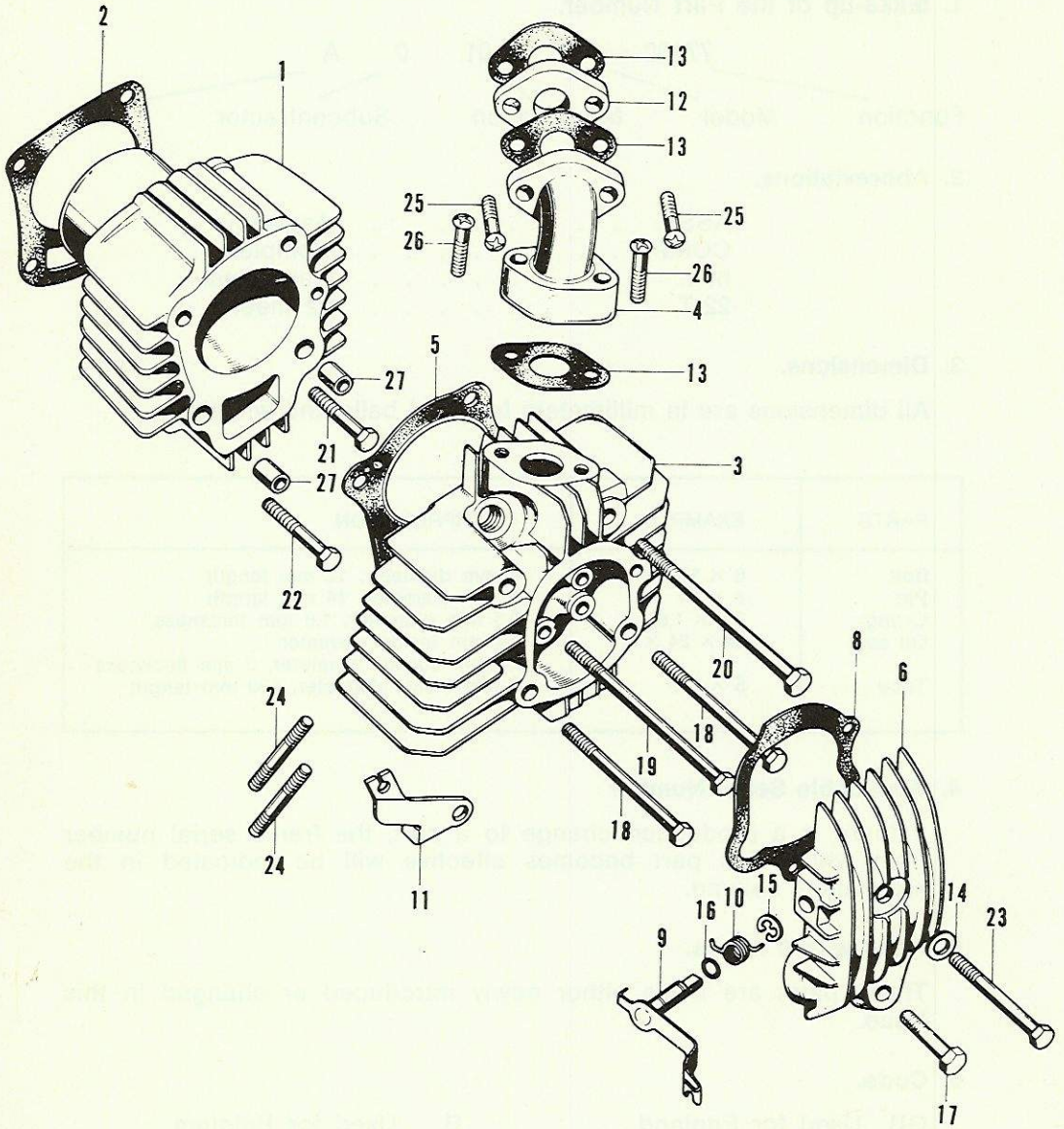

REF. N°.	PART N°.	DESCRIPTION	St.	R	NoR	SERIE N°.
1	12100-081-010	CYLINDER	1	1	1	C00001/C45463
	12100-114-000	CYLINDER	1	1	1	C45464
2	12191-081-000	GASKET, cylinder	1	1	1	C00001/C45463
	12191-114-000	GASKET, cylinder	1	1	1	C45464
3	12200-081-000	HEAD, cylinder	1	1	1	C00001-C07226
	12200-081-010	HEAD, cylinder	1	1	1	C07227
4	12210-081-000	PIPE COMP., inlet	1	1	1	
	12210-081-680	PIPE COMP., inlet (to use with common carburator)	1	1	1	see note
5	12251-081-000	GASKET, cylinder head	1	1	1	
6	12301-081-040	COVER, cylinder head	1	1	1	C07101-C07226
7	12301-081-060	COVER, cylinder head	1	1	1	C07227
8	12391-081-000	GASKET, cylinder cover head	1	1	1	C00001-C07226
	12391-081-040	GASKET, cylinder cover head	1	1	1	C07227
9	14920-081-020	SHAFT COMP., decomp.	1	1	1	
10	14935-081-010	SPRING, decomp. return	1	1	1	
11	14945-081-010	BRACKET, decomp.	1	1	1	
12	16265-081-000	INSULATOR, carburator	1	1	1	
13	16267-081-000	GASKET, inlet pipe	3	3	3	(only 2 for comm. carburator)
14	90478-700-000	WASHER A, 6 mm.	1	1	1	
15	90607-081-000	CIRCLIP, 7 mm.	1	1	1	
16	91301-216-000	O-RING, 5,5 X 1.5	1	1	1	
17	92000-06020	BOLT, hex., 6 X 20	1	1	1	
18	92000-06071	BOLT, hex., 6 X 71	2	2	2	
19	92000-06100	BOLT, hex., 6 X 100	1	1	1	
20	92000-06112	BOLT, hex., 6 X 112	1	1	1	
21	92100-06028	BOLT, hex., 6 X 28	1	1	1	
22	92100-06032	BOLT, hex., 6 X 32	1	1	1	
23	92100-06056	BOLT, hex., 6 X 56	1	1	1	
24	92700-06030	BOLT, stud, 6 X 30	2	2	2	
	92700-06027-10	BOLT, stud, 6 X 27	2	2	2	
25	93500-06020	SCREW, pan, 6 X 20	2	2	2	
26	93500-06025	SCREW, pan, 6 X 25	2	2	2	
27	94301-08120	PIN, A Dowel, 8 X 12	2	2	2	

Note : No. 4

-12210-081-000 PIPE COMPL., inlet

For F till frame No. 218800

For UK till frame No. 216762

For B and NL till frame No. ....

-12210-081-680 PIPE COMPL., inlet (Common carb.)

For F from frame No. 218801

For UK from frame No. 216763

For B and NL from frame No. ....

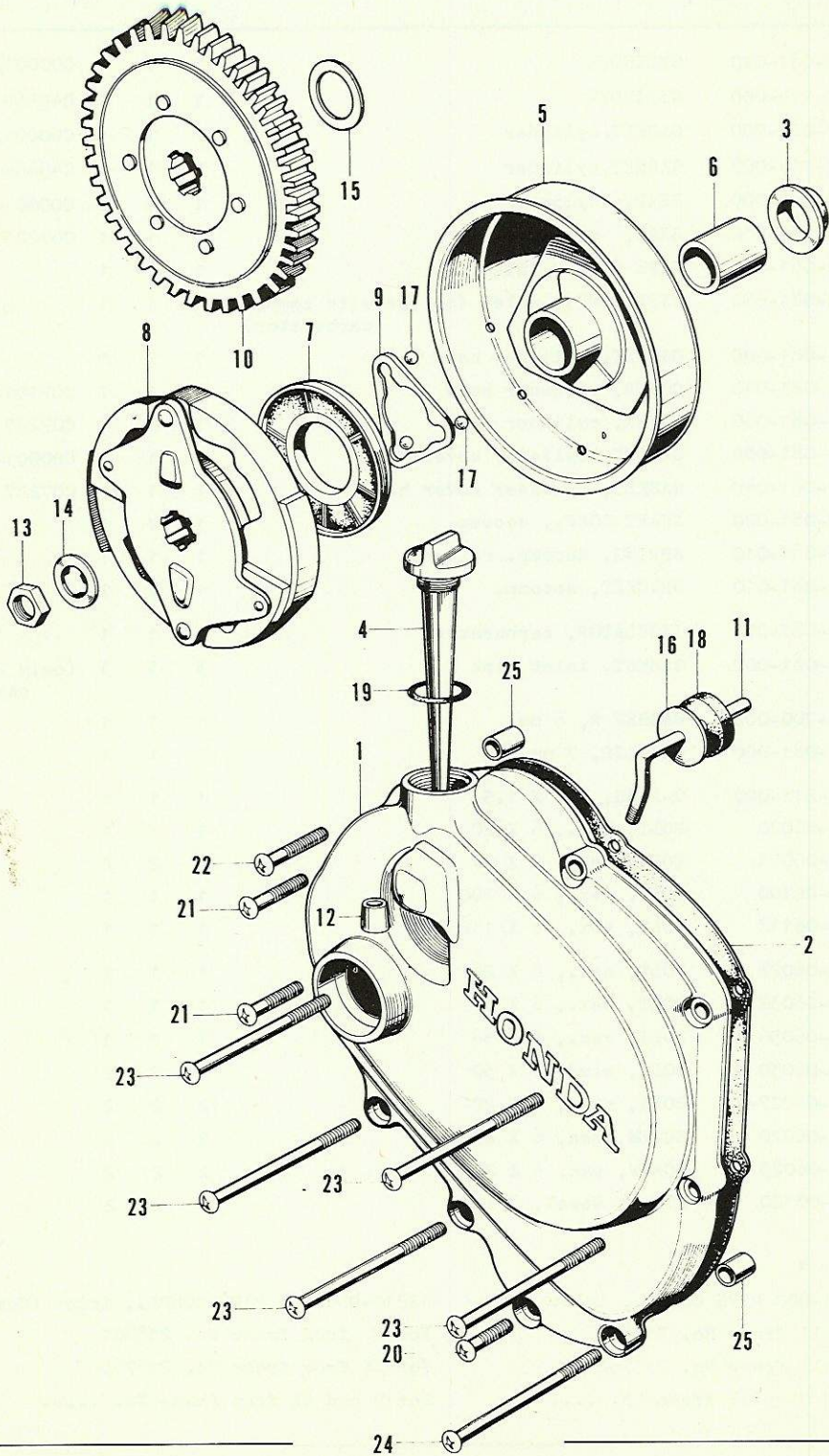



REF. N°.	PART N°.	DESCRIPTION	St.	R	NoR	REMARKS
1	11331-081-000	COVER, R., crankcase	1	1	1	
2	11394-081-010	GASKET, R., crankcase cover	1	1	1	
3	14315-081-000	COLLAR, timing sprocket distance	1	1	1	
4	15650-040-000	GAUGE, oil	1	1	1	
5	22100-081-000	OUTER COMP., clutch (18T)	1	1	1	
6	22131-081-000	GUIDE, clutch center	1	1	1	
7	22201-044-050	PLATE, clutch friction	1	1	1	
8	22300-081-000	PLATE ASSY., drive	1	1	1	
9	22802-044-000	RETAINER, ball	1	1	1	
10	23110-081-020	GEAR COMP., primary driven (54T)	1	1	1	
11	24611-081-010	SLIDER, main shaft	1	1	1	
12	24612-063-000	CAP, free pawl slider	1	1	1	
13	90231-816-000	NUT, lock, 14 mm.	1	1	1	
14	90434-816-000	WASHER, lock, 14 mm.	1	1	1	
15	90451-081-000	WASHER A, thrust, 17 mm.	1	1	1	
16	90456-081-000	WASHER, 5 X 30	1	1	1	
17	90921-044-000	BALL, clutch	3	3	3	
18	91212-063-005	OIL SEAL, 5 X 30 X 6	1	1	1	
19	91307-035-000	O-RING, 18 X 3	1	1	1	
20	93500-06020	SCREW, pan, 6 X 20	1	1	1	
21	93500-06025	SCREW, pan, 6 X 25	2	2	2	
22	93500-06032	SCREW, pan, 6 X 32	1	1	1	
23	93500-06075	SCREW, pan, 6 X 75	5	5	5	
24	93500-06085	SCREW, pan, 6 X 85	1	1	1	
25	94301-08120	PIN, A, dowel, 8 X 12	2	2	2	

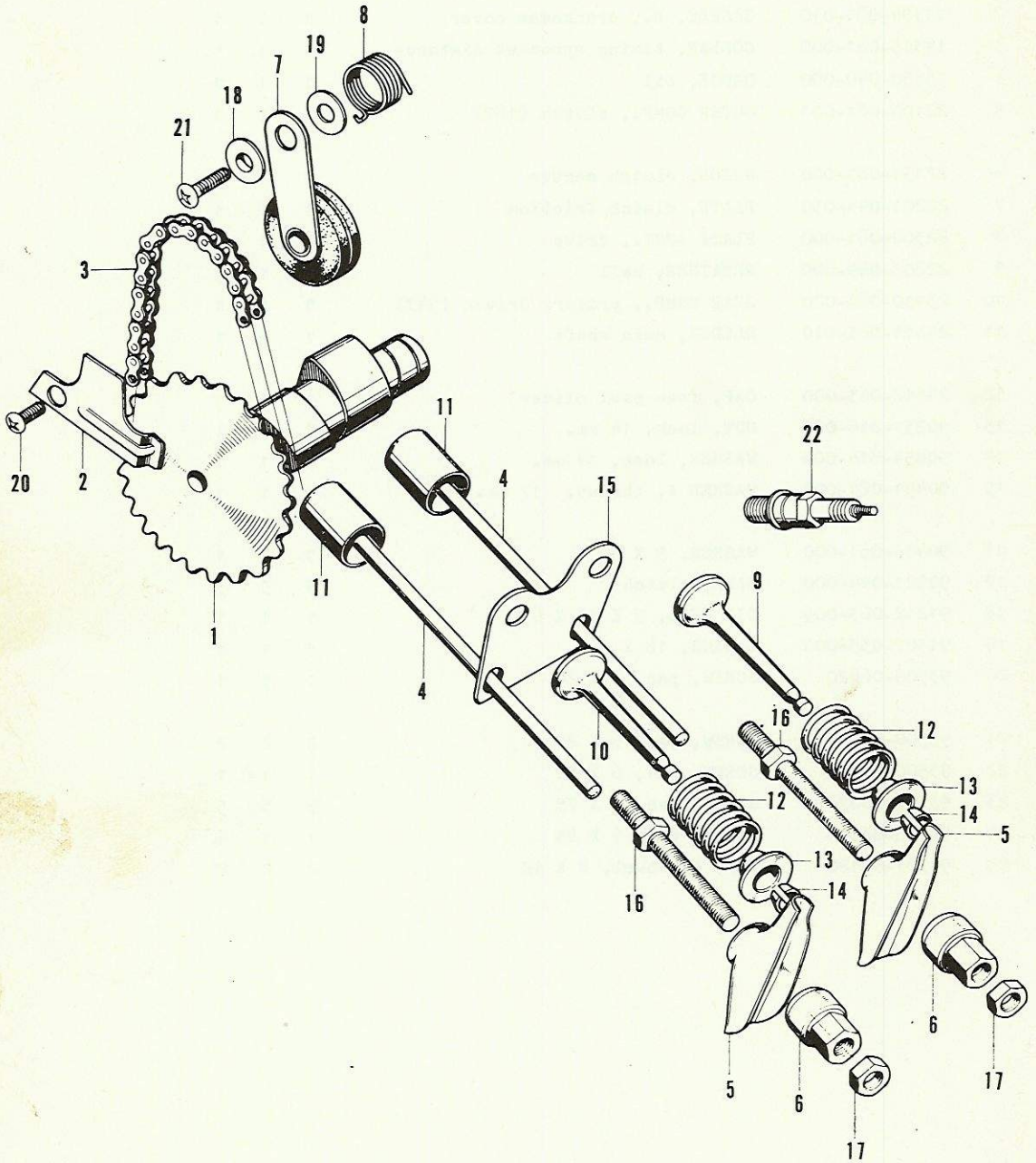

PF 50 E - 3

VALVE - CAM SHAFT

REF. N°.	PART N°.	DESCRIPTION	St.	R	NoR	REMARKS
1	14101-081-010	SHAFT, cam (30T)	1	1	1	
2	14105-081-010	PLATE, cam shaft set	1	1	1	
3	14401-081-000	CHAIN, cam (42 LINKS)	1	1	1	
4	14411-081-000	ROD, push	2	2	2	
5	14431-081-000	ARM, valve rocker	2	2	2	
6	14451-081-000	PIVOT, rocker arm	2	2	2	
7	14500-081-000	TENSIONER COMP., cam chain	1	1	1	
8	14541-081-000	SPRING, cam chain tensioner	1	1	1	
9	14711-081-010	VALVE, inlet	1	1	1	
10	14721-081-010	VALVE, exhaust	1	1	1	
11	14731-081-000	LIFTER, valve	2	2	2	
12	14751-081-000	SPRING, valve	2	2	2	
13	14771-081-010	RETAINER, valve spring	2	2	2	
14	14781-001-010	COTTER, valve	4	4	4	
15	14791-081-000	PLATE, push rod guide	1	1	1	
16	90012-081-010	BOLT, pivot	2	2	2	
17	90206-023-000	NUT, pivot adjuster	2	2	2	
18	90445-081-000	WASHER, 6 mm.	1	1	1	
19	90511-216-670	WASHER, 6 X 17	1	1	1	
20	93500-06012	SCREW, pan, 6 X 12	1	1	1	
21	93500-06016	SCREW, pan, 6 X 16	1	1	1	
22	98056-57711	PLUG, sparking C7HS	1	1	1	

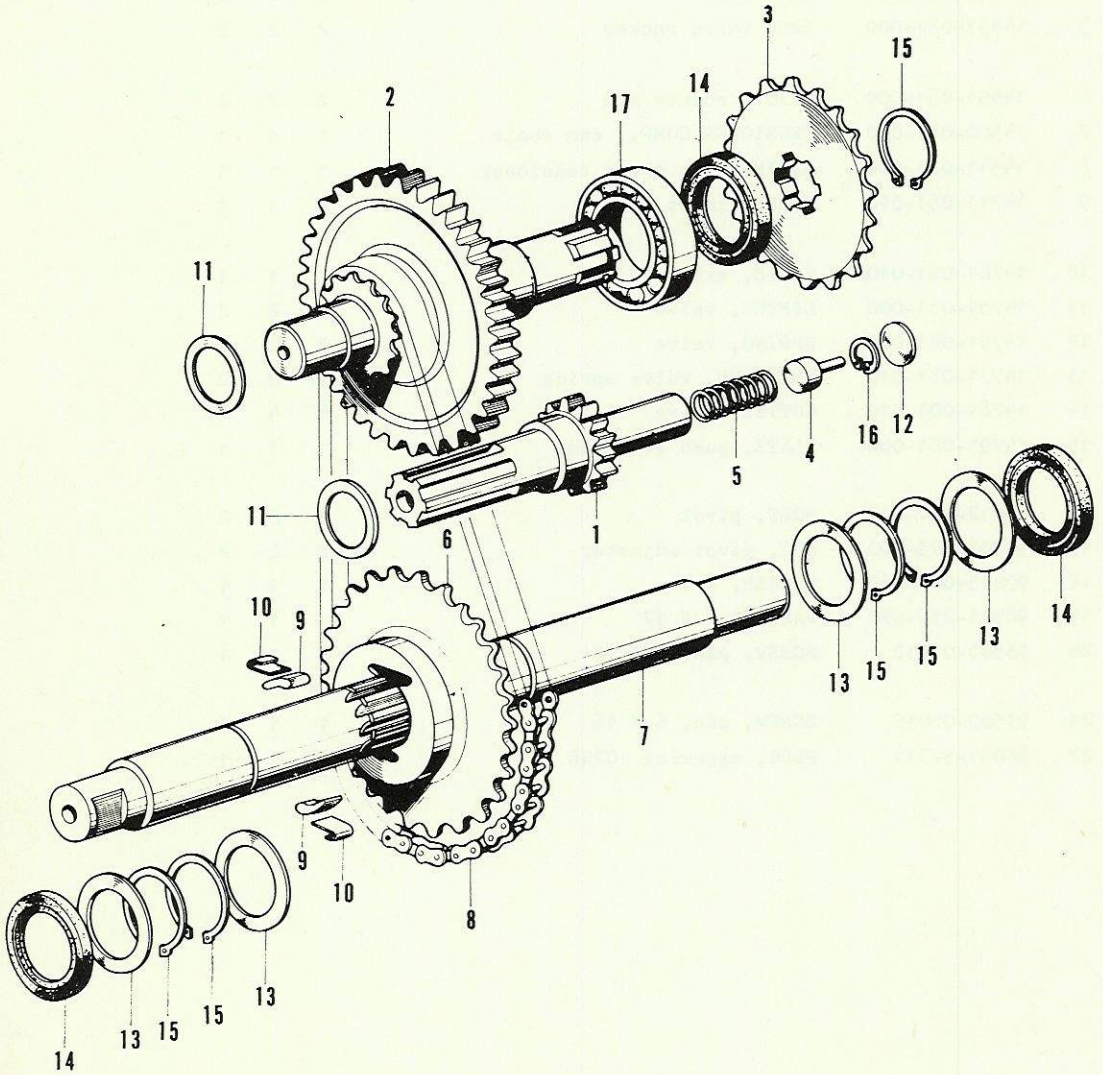

REF. N°.	PART N°.	DESCRIPTION	St.	R	NoR	REMARKS
1	23211-081-000	SHAFT, main, transmission	1	1	1	
2	23220-081-010	SHAFT, counter, transmission	1	1	1	
3	23801-081-000	SPROCKET, drive (15T)	1	1	1	
4	24111-081-000	PIECE, push	1	1	1	
5	24621-081-000	SPRING, free pawl	1	1	1	
6	28802-081-020	SPROCKET, starter drive (29T)	1	1	1	
7	28811-081-000	SHAFT, pedal	1	1	1	
8	28813-081-000	CHAIN, pedal shaft (36 LINKS)	1	1	1	
9	28815-081-010	PAWL, ratchet	2	2	2	
10	28817-081-030	SPRING, set, ratchet pawl	2	2	2	
11	90451-081-000	WASHER A, thrust, 17 mm.	2	2	2	
12	90461-081-000	WASHER, 15 mm.	1	1	1	
13	90469-081-010	WASHER, 20 mm.	4	4	4	
14	91203-081-005	OIL SEAL, 20 X 30 X 6	3	3	3	
15	94510-20000	CIRCLIP, ex., 20 mm.	5	5	5	
16	94520-10000	CIRCLIP, in., 10 mm.	1	1	1	
17	96100-60040	BEARING, ball, 6004	1	1	1	

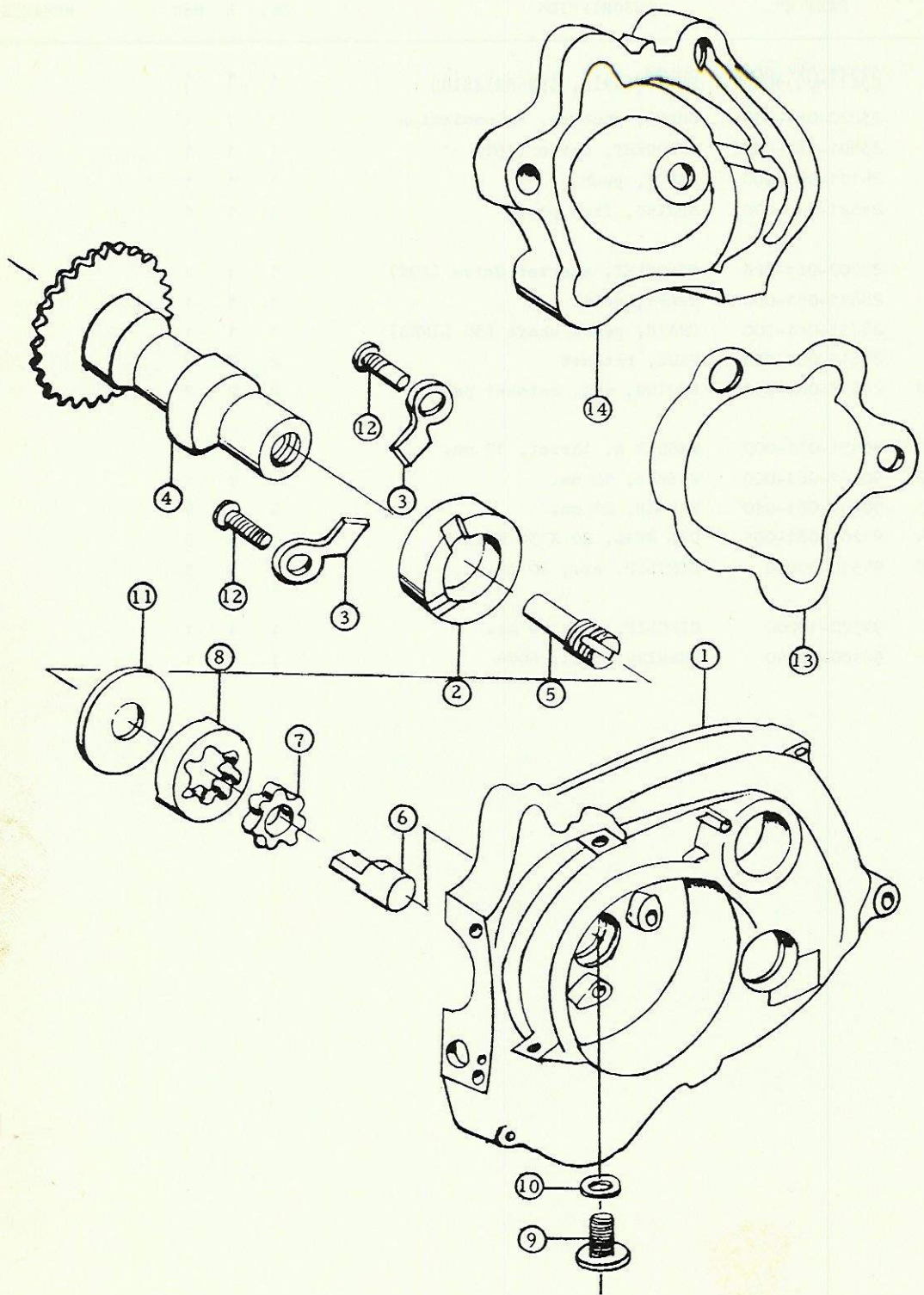

REF. N°.	PART N°.	DESCRIPTION	St.	R	NoR	REMARKS
1	11200-081-030	CASE, L., crank	1	1	1	
2	11215-114-010	BUSH, 17.5 mm.	1	1	1	
3	11218-081-010	PLATE, bush set, 17,5 mm.	2	2	2	
4	14101-081-020	SHAFT, cam	1	1	1	
5	15381-081-000	SHAFT A, oil pump drive	1	1	1	
6	15382-081-000	SHAFT B, oil pump drive	1	1	1	
7	15331-035-000	ROTOR, oil pump inner	1	1	1	
8	15332-035-000	ROTOR, oil pump outer	1	1	1	
9	90081-044-000	BOLT, sealing, 8 mm.	1	1	1	
10	90488-044-000	WASHER, 8 mm.	1	1	1	
11	90471-081-000	WASHER, pump side	1	1	1	
12	93500-06014	PAN, screw 6 X 14	2	2	2	
13	12391-081-040	GASKET, cylinder head cover	1	1	1	
14	12301-081-060	COVER, cylinder head	1	1	1	

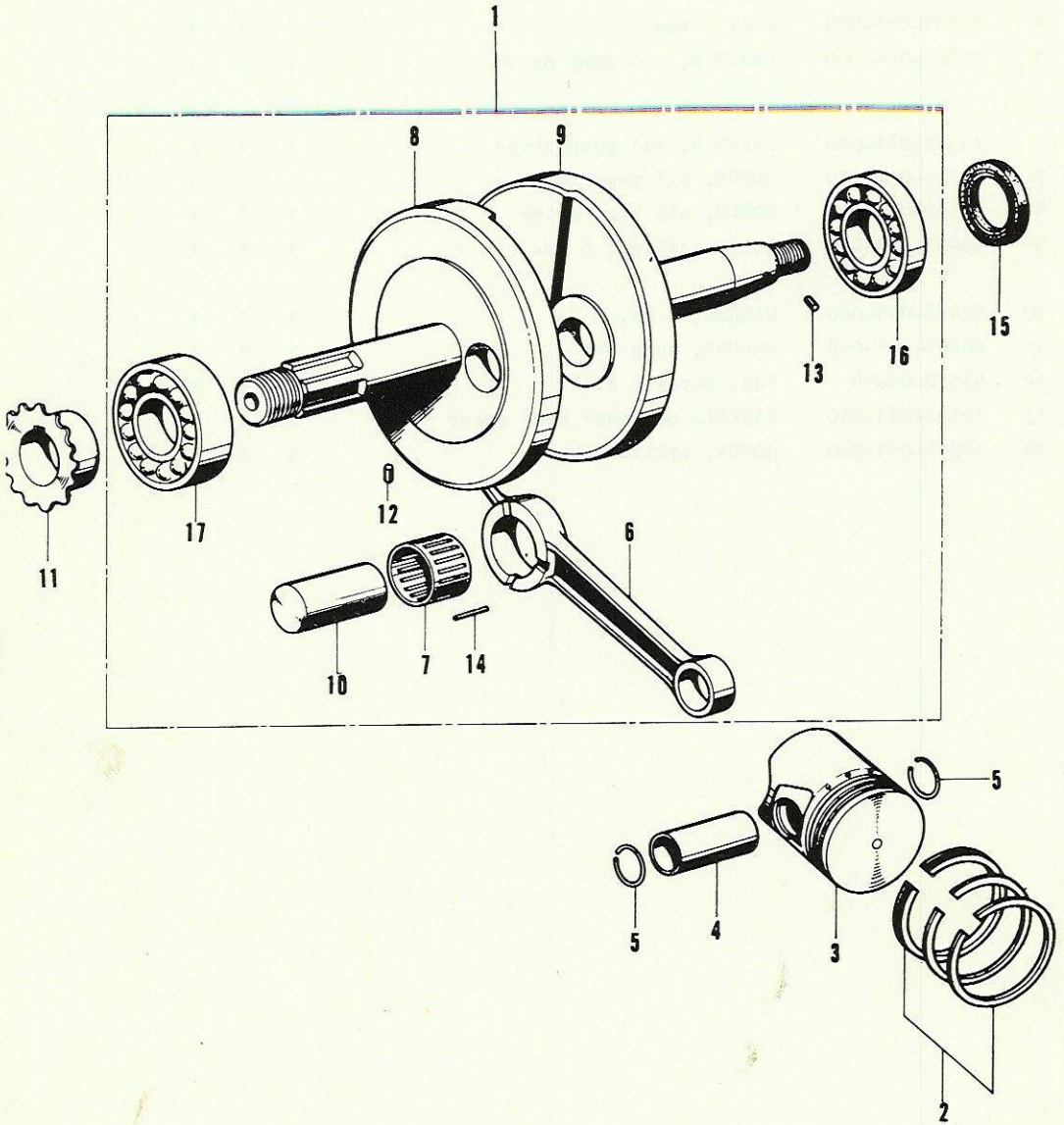



REF. N°.	PART N°.	DESCRIPTION	St.	R	NoR	REMARKS
1	13000-081-010	SHAFT COMP., crank	1	1	1	
2	13010-044-000	RING SET, piston (STD)	1	1	1	
	13020-044-000	RING SET, piston (0.25)	1	1	1	
	13030-044-000	RING SET, piston (0.50)	1	1	1	
	13040-044-000	RING SET, piston (0.75)	1	1	1	
	13050-044-000	RING SET, piston (1.00)	1	1	1	
3	13101-081-000	PISTON (STD)	1	1	1	
	13102-081-000	PISTON (0.25)	1	1	1	
	13103-081-000	PISTON (0.50)	1	1	1	
	13104-081-000	PISTON (0.75)	1	1	1	
	13105-081-000	PISTON (1.00)	1	1	1	
4	13111-044-010	PIN, piston	1	1	1	
5	13115-001-000	CLIP, piston pin	2	2	2	
6	13201-063-300	ROD, connecting	1	1	1	
7	13211-044-030	RETAINER, roller	1	1	1	
8	13311-081-310	SHAFT, R. crank comp.	1	1	1	
9	13321-063-310	SHAFT, L. crank comp.	1	1	1	
10	13381-063-300	PIN, crank	1	1	1	
11	14311-081-010	SPROCKET, timing (15T)	1	1	1	
12	90719-081-000	PIN, timing	1	1	1	
13	90741-122-000	PIN, dowel, 3 X 4	1	1	1	
14	91101-205-010	ROLLER, rod, 2.5 X 8.5	20	20	20	
15	91211-044-000	OIL SEAL, 15 X 25 X 6	1	1	1	
16	96100-62020	BEARING, ball, 6202	1	1	1	
17	96100-62030	BEARING, ball, 6203	1	1	1	

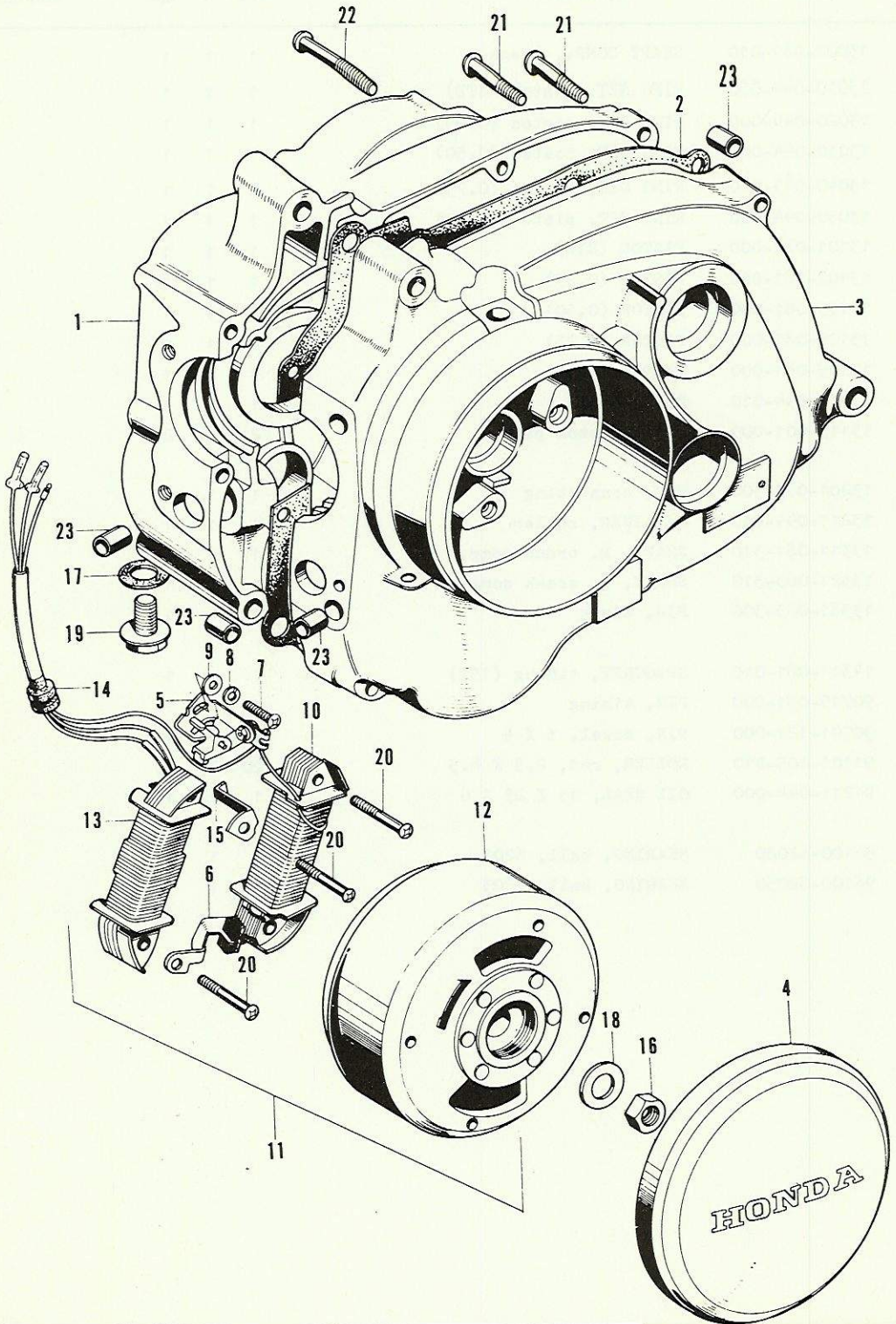

REF. N <sup>o</sup> .	PART N <sup>o</sup> .	DESCRIPTION	St.	R	NoR	REMARKS
1	11100-081-010	CASE COMP., right crank	1	1	1	
2	11191-081-000	GASKET, crankcase	1	1	1	
3	11200-081-030	CASE COMP., left crank	1	1	1	
4	11431-063-000	COVER, dynamo	1	1	1	
5	30202-063-004	BREAKER, contact (NIPPON DENSO)	1	1	1	
6	30205-044-004	FELT COMP., oil (NIPPON DENSO)	1	1	1	
	30205-816-650	FELT COMP., oil (GB)	1	1	1	
7	30207-063-004	SCREW, breaker set (NIPPON DENSO)	1	1	1	
8	30208-063-004	WASHER, spring (NIPPON DENSO)	1	1	1	
9	30209-063-004	WASHER, plain (NIPPON DENSO)	1	1	1	
10	30541-063-004	COIL COMP., primary (NIPPON DENSO)	1	1	1	
11	31100-081-601	A.C. GENERATOR, Assy., flywheel (NIPPON DENSO) (GB) (15/15W)	1	1	1	CE08351/CE59184
	31100-081-602	A.C. GENERATOR, Assy. flywheel (18/18W) (GB)	1	1	1	CE59185
	31100-099-620	A.C. GENERATOR, Assy. flywheel (F)	1	1	1	CE10061
	31100-081-690	A.C. GENERATOR, Assy. flywheel (NL - B) 40 km/h.	1	1	1	CH31550
	31100-063-621	A.C. GENERATOR, Assy. flywheel (B) > 40 km/h.	1	1	1	
12	31121-081-601	FLYWHEEL COMP. (NIPPON DENSO) (GB) (15/15W)	1	1	1	CE08351/CE59184
	31121-081-602	FLYWHEEL COMP. (NIPPON DENSO) (GB) (18/18W)	1	1	1	CE59185
	31121-099-620	FLYWHEEL COMP. (F)	1	1	1	CF10061
	31121-099-690	FLYWHEEL COMP. (NL & B) 40km/h.	1	1	1	CH31550
	31121-063-621	FLYWHEEL COMP. (B) > 40 km/h.	1	1	1	
13	31631-081-601	COIL COMP., lamp (NIPPON DENSO) (GB) (15/15W)	1	1	1	CF08351/CF59184
	31631-081-602	COIL COMP., lamp (GB) (18/18W)	1	1	1	CE59185
	31631-063-621	COIL COMP., lamp (F & B > 40 km/h.)	1	1	1	
	31631-063-691	COIL COMP., lamp (B & NL 40 km/h.)	1	1	1	

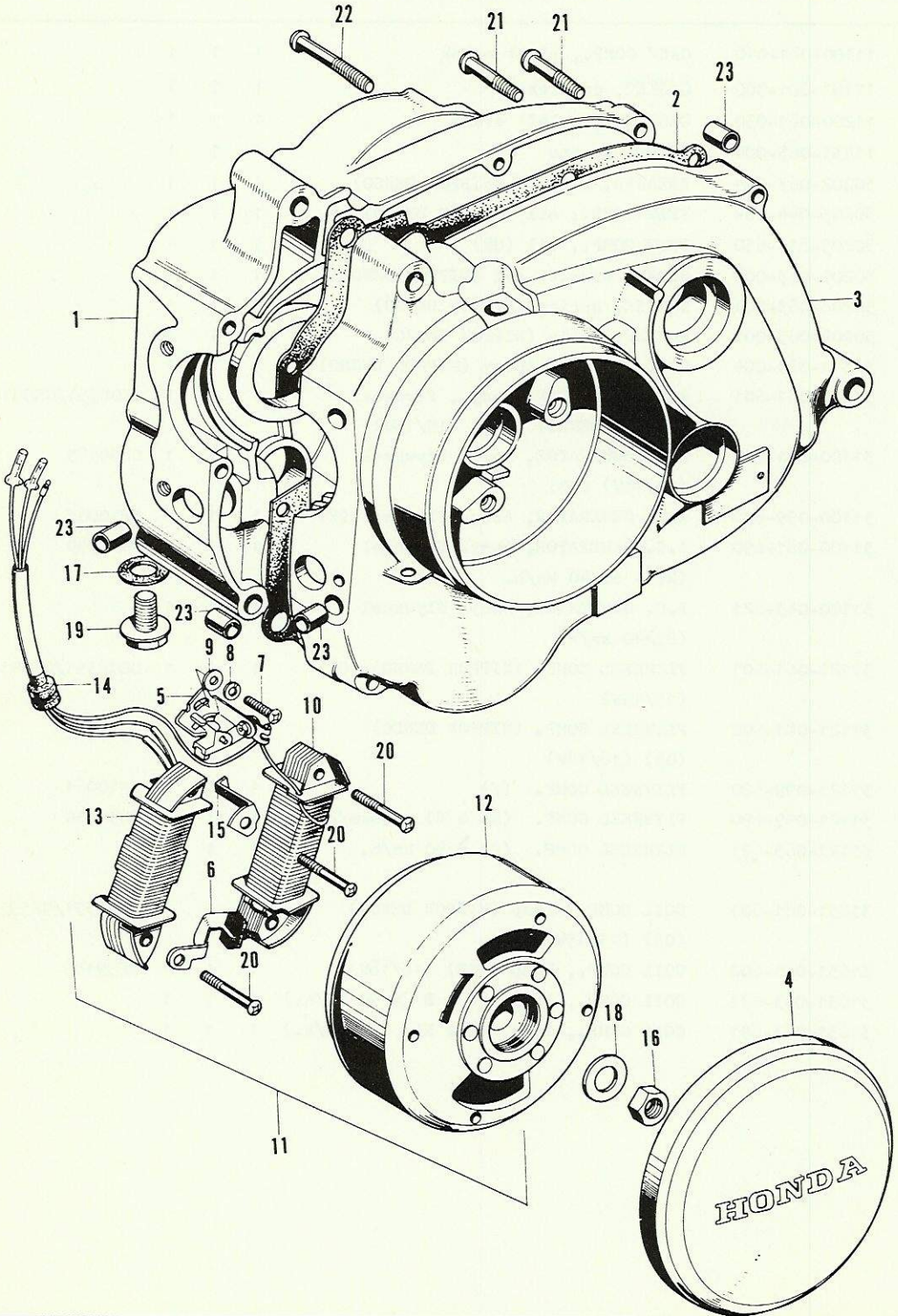

REF. N°.	PART N°.	DESCRIPTION	St.	R.	NoR	SERIE N°.
14	32956-063-300	GROMMET, dynamo cord	1	1	1	
15	32957-063-010	CLAMPER, dynamo cord	1	1	1	
	32957-063-670	CLAMPER, dynamo cord (GB) (18/18w)	1	1	1	CE59185
16	94002-10000-0S	NUT, 10 mm.	1	1	1	
17	90407-259-000	PACKING, drain cock	1	1	1	
18	90426-001-000	WASHER, magneto fixing	1	1	1	
19	92800-12000	BOLT, drain plug, 12 mm.	1	1	1	
20	93500-04022-0A	SCREW, pan, 4 X 22	4	4	4	
	93500-04030-0A	SCREW, pan, 4 X 30 (GB) (18/18w)	2	2	2	CE59185
21	93500-06036	SCREW, pan, 6 X 36	3	3	3	
22	93500-06045	SCREW, pan, 6 X 45	1	1	1	
23	94301-08120	PIN, A, dowel, 8 X 12	4	4	4	

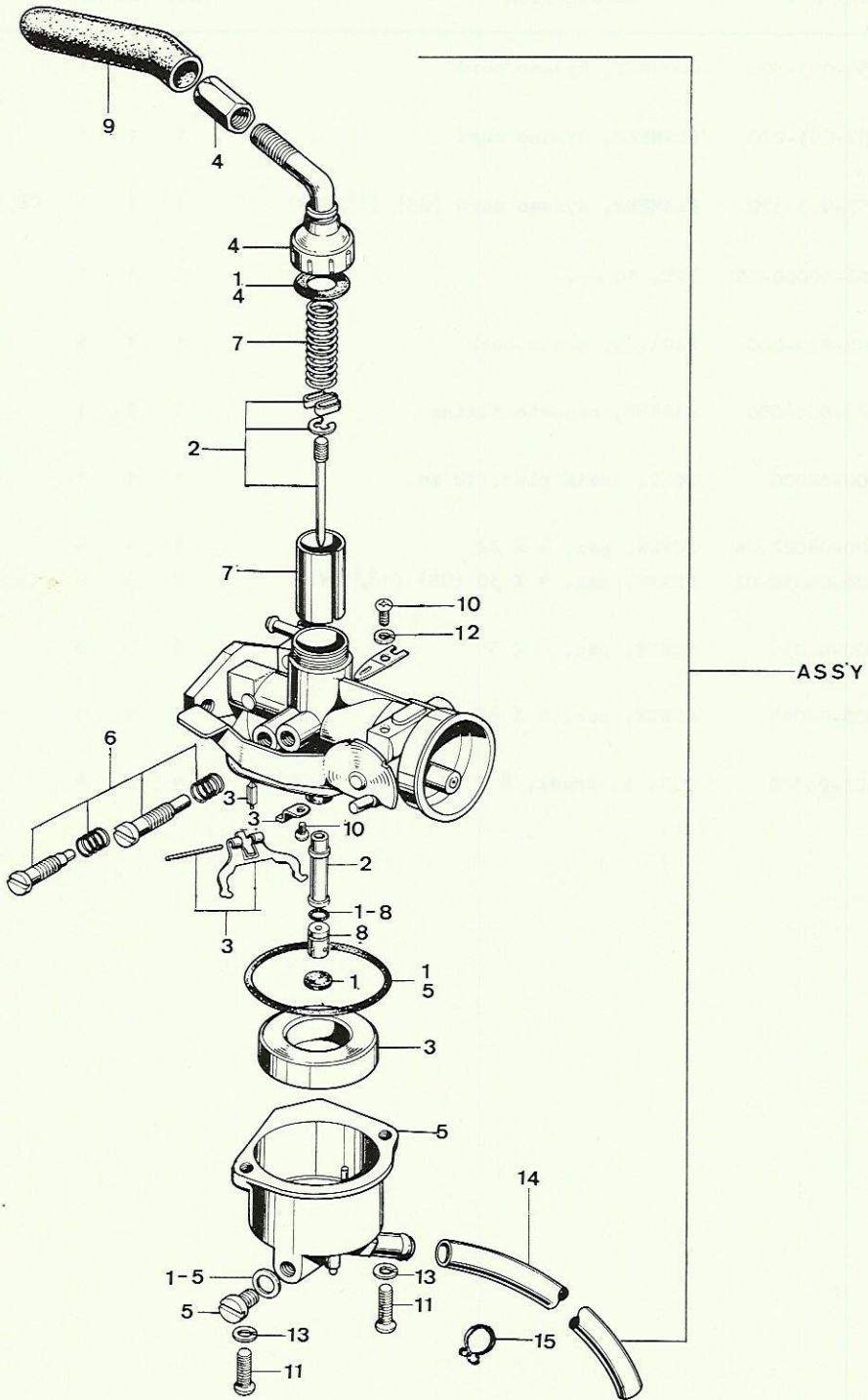

REF. N°.	PART N°.	DESCRIPTION	St.	R	NoR.	REMARKS
	16100-099-602	CARBURATOR ASSY F5A (F-GB-I) (B > 40km/h.)	1	1	1	
	16100-099-692	CARBURATOR ASSY F4A (NL-B) (40km/h.)	1	1	1	
1	16010-063-004	PACKING SET	1	1	1	
2	16012-081-004	NEEDLE SET, jet	1	1	1	
3	16013-064-004	FLOAT SET	1	1	1	
4	16014-064-004	TOP SET	1	1	1	
5	16015-064-004	CHAMBER SET, float	1	1	1	
6	16016-063-004	SCREW SET	1	1	1	
7	16022-063-004	VALVE SET, throttle	1	1	1	
8	99201-063-0550	JET SET, main (≠ 55) (B-NL) (40km/h.)	1	1	1	
	99201-063-0620	JET SET, main (≠ 62) (F-GB-I) (B > 40km/h.)	1	1	1	
9	16194-063-004	CAP, cable	1	1	1	
10	93500-03005-0A	SCREW, pan, 3 X 5	1	1	1	
11	93500-04012-0A	SCREW, pan, 4 X 12	2	2	2	
12	94111-03000	WASHER, spring, 3 mm.	1	1	1	
13	94111-04000	WASHER, spring, 4 mm.	2	2	2	
14	95001-35150	TUBE, fuel, 3,5 X 150	1	1	1	
15	95002-02070	CLIP, tube	1	1	1	

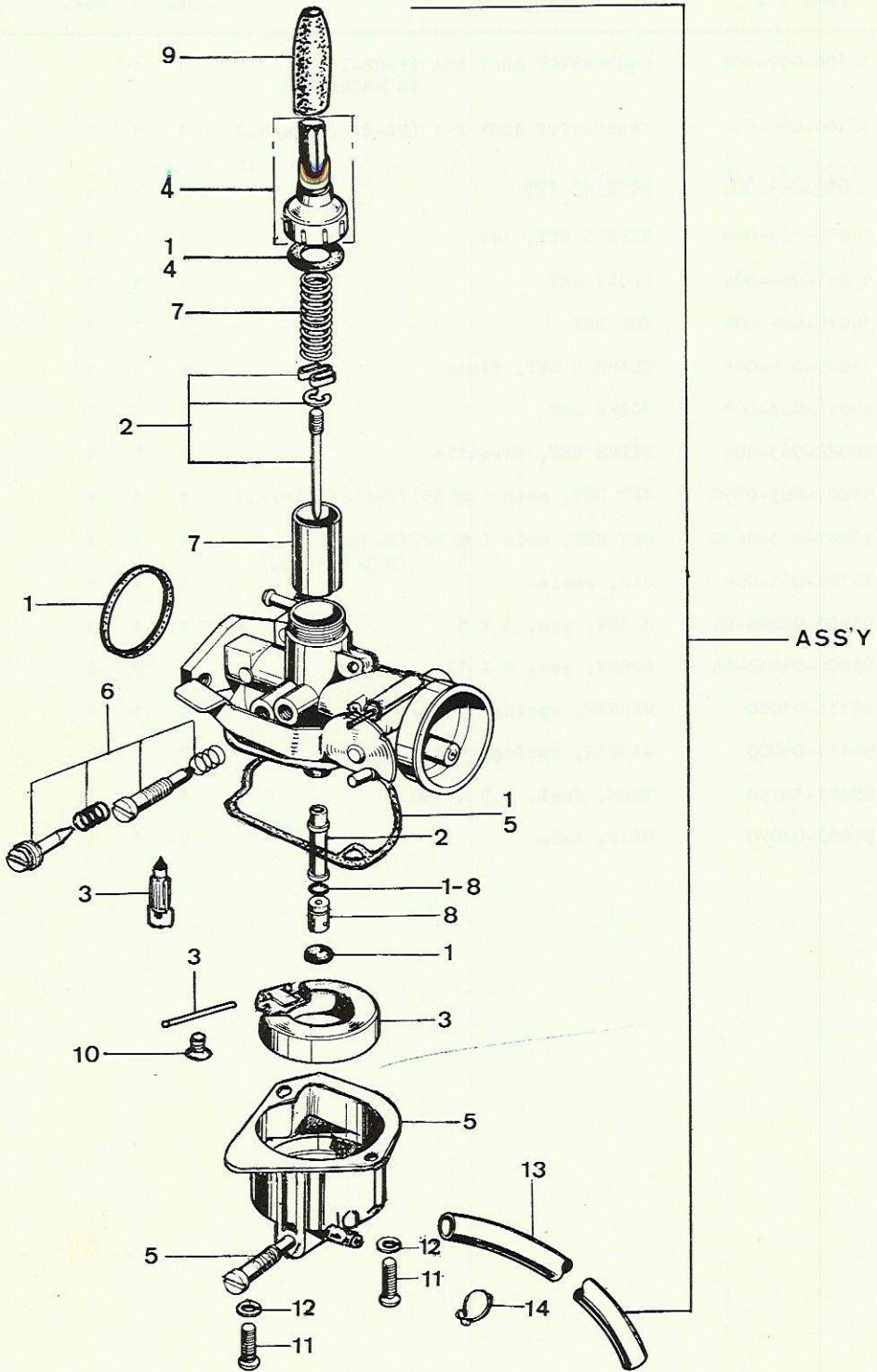



REF. N°.	PART N°.	DESCRIPTION	St.	R	NoR	REMARKS.
	16100-099-693	CARBURATOR ASSY (PA 01-09)(B-NL) (40km/h.)	1	1	1	
	16100-081-024	CARBURATOR ASSY (PA 00-10)(F-GB) (>40km/h.)	1	1	1	
1	16010-081-004	PACKING SET	1	1	1	
2	16012-099-690	NEEDLE SET, jet (B-NL) (40 km/h.)	1	1	1	
	16012-081-014	NEEDLE SET, jet (F-GB)(>40 km/h.)	1	1	1	
3	16013-143-680	FLOAT SET	1	1	1	
4	16014-081-004	TOP SET	1	1	1	
5	16015-081-004	CHAMBER SET, float	1	1	1	
6	16016-143-620	SCREW SET	1	1	1	
7	16022-143-620	VALVE SET, throttle (B-NL) (40km/h.)	1	1	1	
	16022-081-004	VALVE SET, throttle (F-GB)(>40km/h.)	1	1	1	
8	99201-099-065	JET SET, main ( # 65) (B-NL) (40km/h.)	1	1	1	
	99201-081-070	JET SET, main ( # 70) (F-GB)(>40km/h.)	1	1	1	
9	16118-086-004	CAP, cable	1	1	1	
10	93500-04005-OA	SCREW, pan, 4 X 5	1	1	1	
11	93500-04012-OA	SCREW, pan, 4 X 12	2	2	2	
12	94111-04000	WASHER, spring, 4 mm.	2	2	2	
13	95001-35150	TUBE, fuel , 3,5 X 150	1	1	1	
14	95002-02070	CLIP, tube	1	1	1	

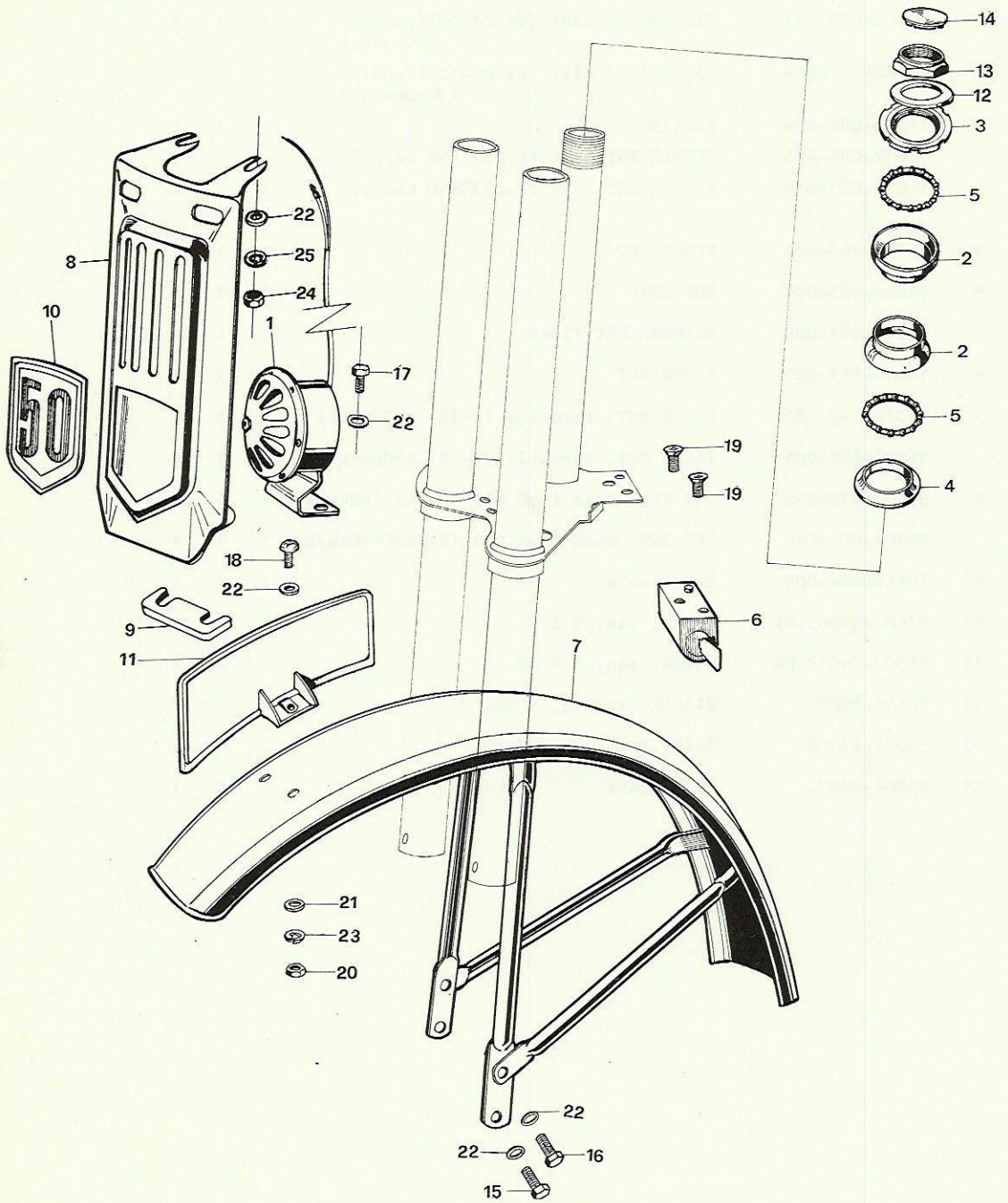

PF 50 F-1

FRONT FENDER

REF. No.	PART N°.	DESCRIPTION	St.	R	NoR	REMARKS
1	38100-099-600	HORN (GB - F)	1	1	1	
2	50301-093-003	RACE, steering ball	2	2	2	
3	53211-093-003	RACE TOP, steering cone	1	1	1	
4	53212-093-003	RACE BOTTOM, steering cone	1	1	1	
5	53213-093-003	CAGE, ball assy	2	2	2	
6	53600-044-000	LOCK, steering handle (all areas except GB)	1	1	1	
7	61100-099-000XL	FENDER, front (Ivory White)	1	1	1	
8	64310-117-000	COVER, top front	-	1	1	see colour
9	51519-117-000	JOINT, top cover	-	1	1	chart
10	87130-117-000	EMBLEM, top cover	-	1	1	
	87130-143-000	EMBLEM, top cover (F - RDX)	-	1	-	
11	87900-099-690	PLATE, ornament (NL)	1	1	1	
12	90201-093-000	WASHER, plain 26 mm.	1	1	1	
13	90301-093-003	NUT, steering head stem	1	1	1	
14	90302-093-000	CAP, steering nut	1	1	1	
15	92000-06012	BOLT, hex, 6 X 12	2	2	2	
16	92000-06015	BOLT, hex, 6 X 15	2	2	2	
17	92000-06018	BOLT, hex, 6 X 18	2	2	2	
18	93500-04012	SCREW, pan 4 X 12	2	2	2	
19	93600-06012	SCREW, flat 6 X 12	2	2	2	
20	94001-04000	NUT, hex, 4 mm.	2	2	2	
21	94101-04000	WASHER, plain, 4 mm.	4	4	4	
22	94101-06000	WASHER, plain, 6 mm.	6	6	6	
23	94111-04000	WASHER, spring, 4 mm.	2	2	2	
24	94001-06000	NUT, hex, 6 mm.	2	2	2	
25	94111-06000	WASHER, spring 6 mm.	2	2	2	

STEERING SET = N° 2 — 5 + 12 + 14

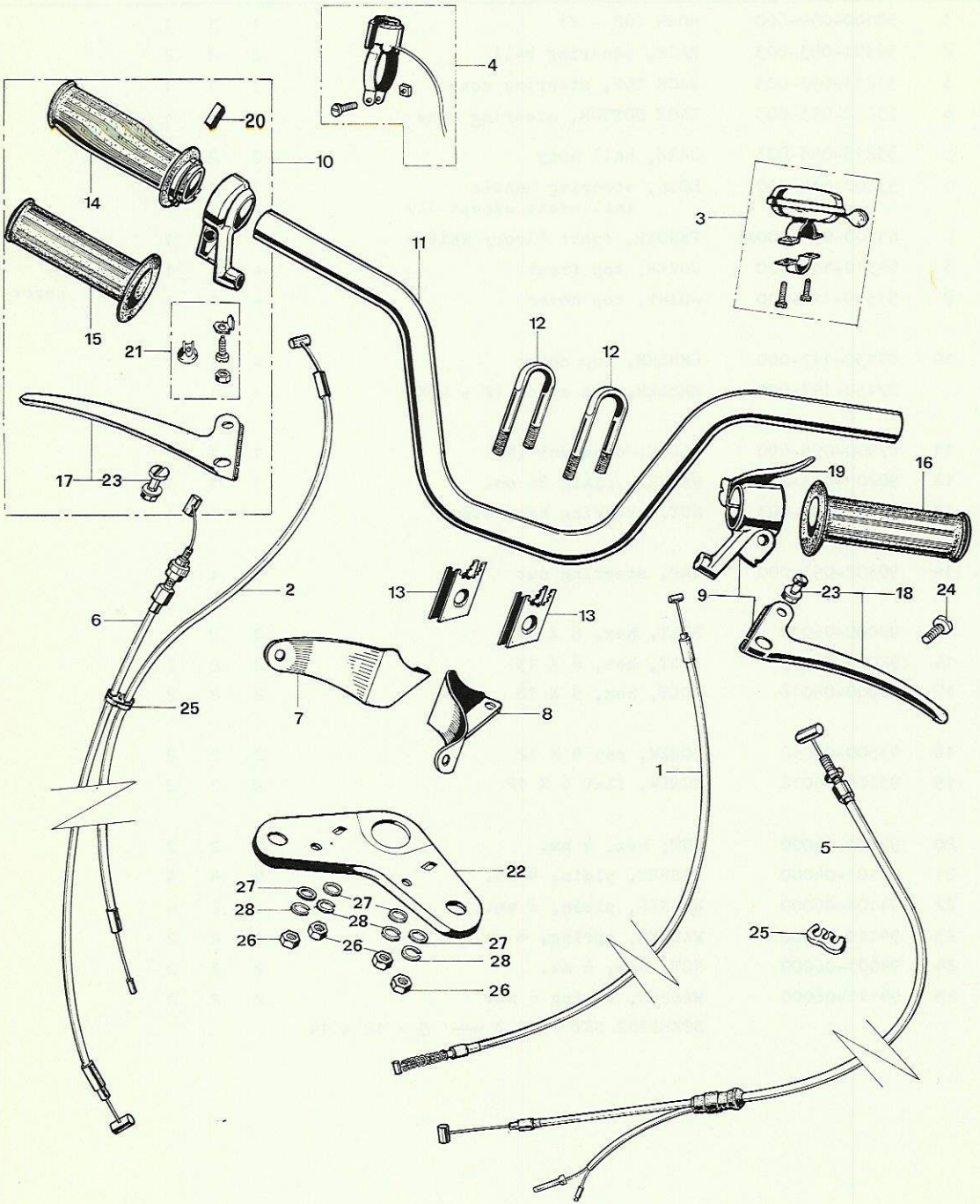

PF 50 F - 2

## STEERING HANDLE

REF. N <sup>o</sup> .	PART N <sup>o</sup> .	DESCRIPTION	St.	R	NoR	SERIE N <sup>o</sup> .
1	14950-099-000	CABLE COMP. decomp.	1	1	1	
2	17910-099-000	CABLE COMP., throttle	1	1	1	
	17910-099-010	CABLE COMP., throttle (for Common Carb.)	1	1	1	see note
3	38110-027-610	BELL	1	1	1	
4	38700-050-620	BUTTON, horn	1	1	1	
5	43450-099-000	CABLE COMP., rear brake(+ stop switch) (B & NL.)	1	1	1	/A62696
	43450-099-930	CABLE COMP., rear brake(+ stop switch) (B-NL & F-RDX & DK R & NoR)	1	1	1	-A62697
	43450-099-680	CABLE COMP., rear brake (F & GB & DK & I)	1	-	-	/A57716
	43450-099-681	CABLE COMP., rear brake (F & GB & DK & I)	1	-	-	-A67717
6	45450-093-000	CABLE COMP., front brake	1	1	1	
7	51516-093-000	STAY, headlight, right	1	1	1	
8	51517-093-000	STAY, headlight, left	1	1	1	
9	53001-093-003B	HANDLE GRIP, brake ASSY (Black)	1	-	-	/A62696
	53001-093-013B	HANDLE GRIP, brake ASSY (Black)	1	1	1	-A62697
10	53002-093-013B	HANDLE GRIP, throttle ASSY (Black)	1	1	1	
11	53100-099-000	PIPE COMP., steering handle	1	1	1	
12	53111-093-000	HOLDER, handle pipe	2	2	2	
13	53112-093-000	BASE, handle pipe holder	2	2	2	
14	53141-093-003B	PIPE, throttle grip (Black)	1	1	1	
15	53165-093-003B	RUBBER, right grip (Black)	1	1	1	
16	53166-093-003B	RUBBER, left grip (Black)	1	1	1	
17	53170-093-013	LEVER RIGHT ASSY., handle grip	1	1	1	
18	53180-093-013	LEVER LEFT ASSY., handle grip	1	1	1	
19	53181-093-003	LEVER, decomp.	1	1	1	
20	53154-093-003	SPRING BRAKE, throttle handle grip	1	1	1	
21	53169-093-003	STOPPER holder set	1	1	1	
22	53230-093-000MS	BRIDGE, fork top (Metallic Silver)	1	1	1	
23	90114-093-013	SCREW, handle grip lever pivot	2	2	2	
24	90115-093-003	SCREW, handle grip setting	1	1	1	
25	90504-099-003	CLIP, cable	2	2	2	
26	94001-06000	NUT, hex 6 mm.	4	4	4	
27	94101-06000	WASHER, plain, 6 mm.	4	4	4	
28	94111-06000	WASHER, spring, 6 mm.	4	4	4	

Note : No. 2

<p>-17910-099-000 CABLE COMPL., throttle          For F till frame No. 218800          For UK till frame No. 216763          For B and NL till frame No. ....</p>	<p>-17910-099-010 CABLE COMPL., throttle (Common carb.)          For F from frame No. 218801          For UK from frame No. 216763          For B and NL from frame No. ....</p>
---	--

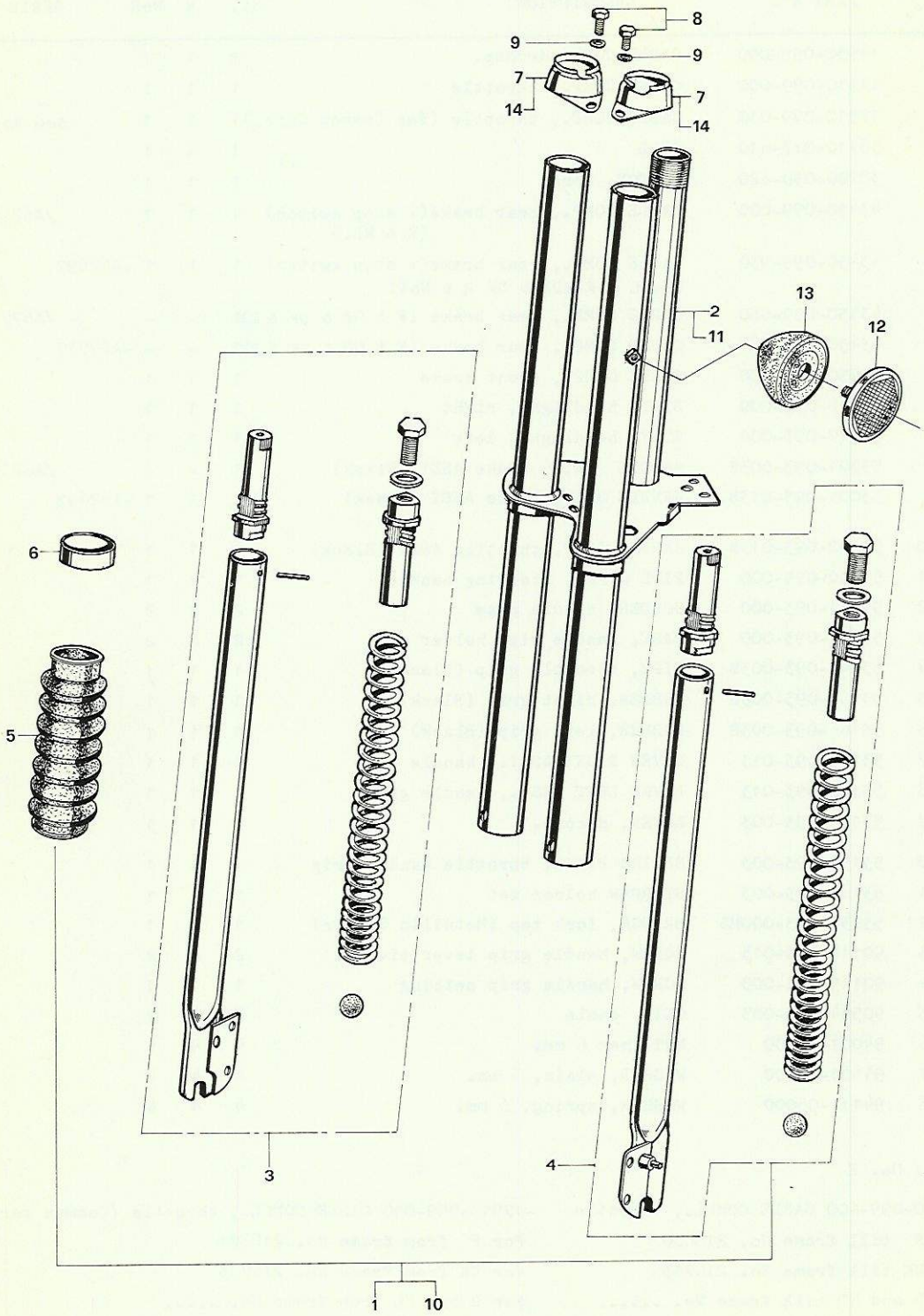

PF 50

F - 3

FRONT FORK

REF. N°.	PART N°.	DESCRIPTION	St.	R	NoR	SERIE N°.
1	51500-099-010	FORK ASSY, front	1	1	1	°
2	51510-099-010	FORK COMP., front	1	1	1	°
3	51520-099-010	PIPE, slide compl., right front fork	1	1	1	°
4	51530-099-010	PIPE, slide compl., left front fork	1	1	1	°
5	51505-093-000B	BOOT, front fork (Black)	2	2	2	
6	51518-093-000	BAND, chrome, front fork	2	2	2	
7	51602-093-000	COVER, front fork	2	2	2	
8	92000-06008	BOLT, hex, 6 X 8 mm.	2	2	2	
9	94101-06000	WASHER, plain 6 mm.	2	2	2	
10	51500-099-303	FORK, ASSY. front (B-only)	-	1	1	-A61647°
11	51510-099-303	FORK COMP., front (B-only)	-	1	1	°
12	33741-099-303	REFLEX, reflector front (B-only)	-	2	2	
13	33744-099-303	BASE, reflector front (B-only)	-	2	2	
14	51602-093-303	COVER, front fork (B-only)	-	2	2	

FORK ASSY FRONT 51500-099-010=N° 1 — 9 + BRIDGE, FORK TOP- (N°53230-093-000)MS

FORK ASSY FRONT 51500-099-303=N° 10 14 + BRIDGE, FORK TOP- (N°53230-093-000)MS

° see colour chart

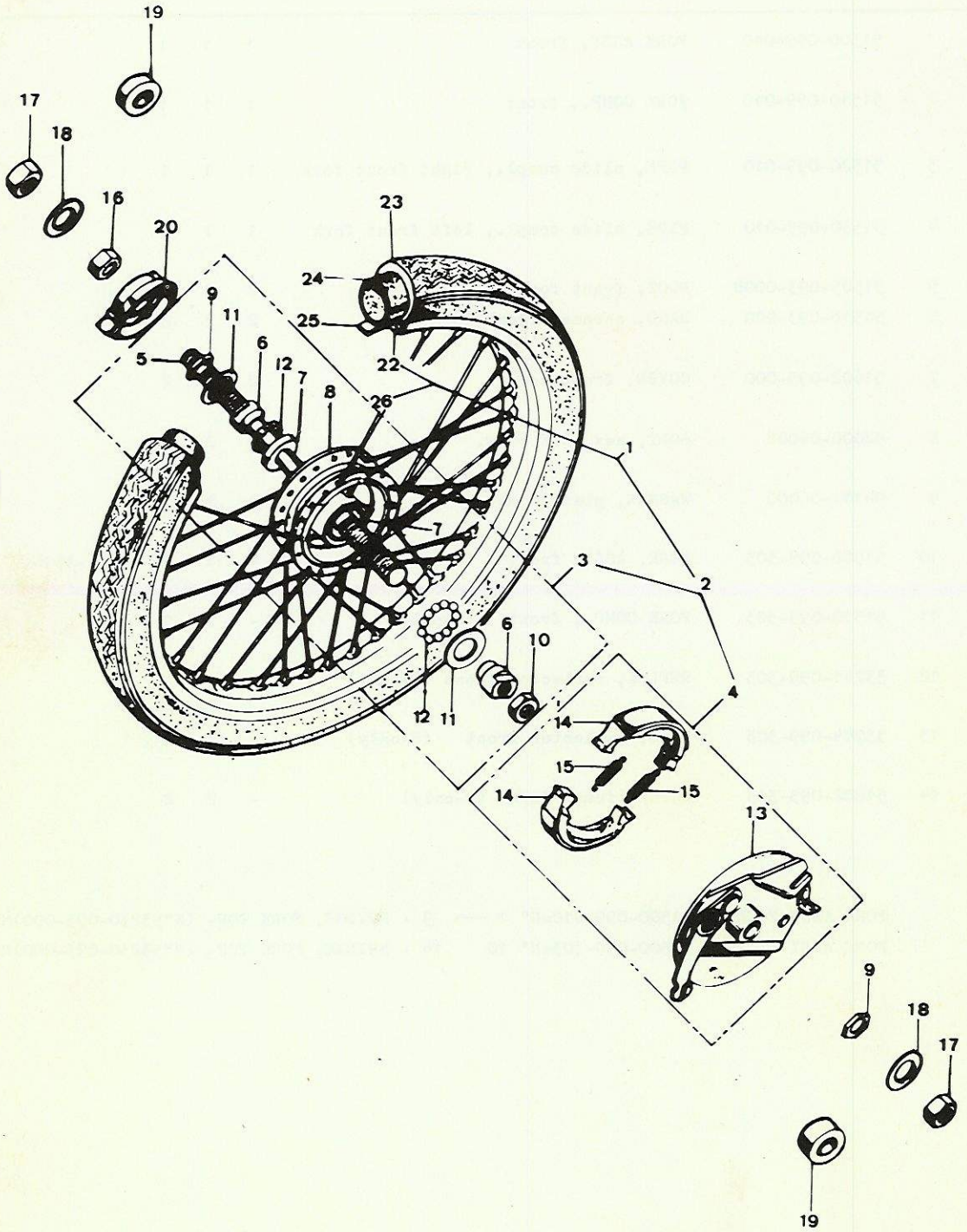



REF. N°.	PART N°.	DESCRIPTION	St.	R	NoR	REMARKS
1	44600-099-000	WHEEL ASSY, front	1	1	1	
0 2	44620-093-000	HUB & PANEL ASSY, front	1	1	1	
3	44610-093-000	HUB ASSY, front	1	1	1	
4	45050-093-001	PANEL ASSY, front brake	1	1	1	
5	44301-093-003	AXLE, front wheel	1	1	1	
6	44302-093-003	CONE RACE, front wheel	2	2	2	
7	44303-093-003	CASE BALL, front wheel	2	2	2	
8	44601-093-003	HUB, front wheel	1	1	1	
9	90313-093-003	NUT B HEX, thin 11 mm.	2	2	2	
10	90314-093-003	NUT A HEX, thin 11 mm.	1	1	1	
11	90505-093-003	WASHER, plain, 29.2 mm.	2	2	2	
12	96211-07000	BALL, steel 5,55 Ø	22	22	22	
0 13	45100-093-013	PANEL COMP., front brake	1	1	1	
14	45120-093-003	SHOE, brake comp.	2	2	2	
15	45133-093-003	SPRING, brake shoe	2	2	2	
16	90312-099-003	NUT, hex, 11 mm. th. 7 mm.	1	1	1	
17	94001-11000	NUT, hex, 11 mm.	2	2	2	
18	94101-11000	WASHER, plain 11 mm. (DIN 126)	2	2	2	
19	44311-093-000	COLLAR R & L, front axle	2	2	2	
20	44800-099-003	GEAR BOX, speedometer	1	1	1	
21	42701-122-690	RIM, wheel 17"	1	1	1	
22	44711-099-158	TIRE, front wheel 17"	1	1	1	
23	44712-099-158	TUBE, front wheel 17"	1	1	1	
24	44713-099-158	FLAP, tire	1	1	1	
25	97463-11214	SPOKE, front # 13	36	36	36	Nipple incl.

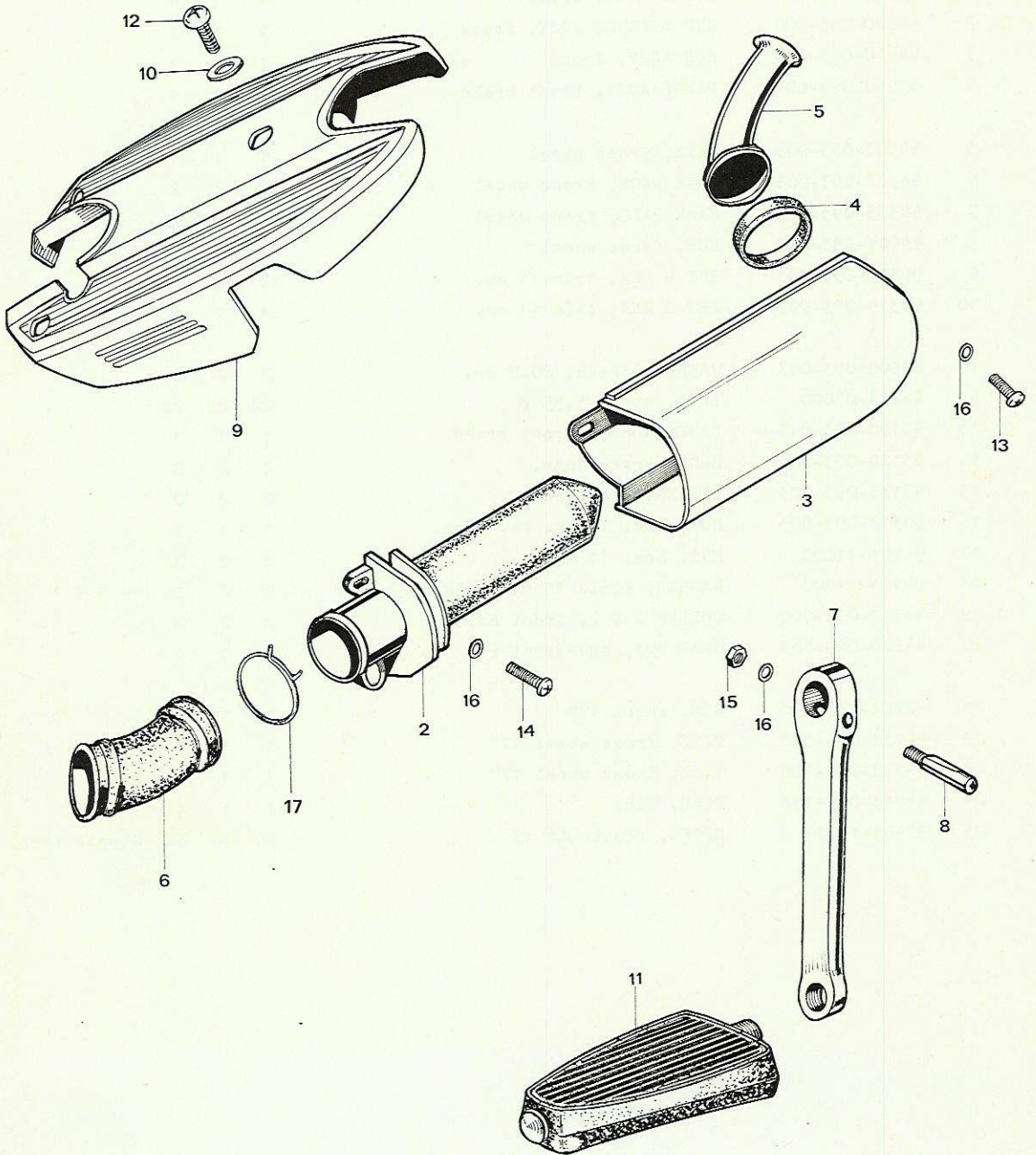

PF 50 F - 5

AIR CLEANER - CRANK ARM - ENGINE COVER

REF. N°.	PART N°.	DESCRIPTION	St.	R	NoR
2	17205-063-020	ELEMENT, air cleaner	1	1	1
3	17225-063-020XL	CASE, air cleaner (Ivory White)	1	1	1
4	17227-063-010	PACKING, inlet tube	1	1	1
5	17251-081-000	TUBE, air cleaner inlet (GB-F-B > 40km/h)	1	1	1
	17251-044-010	TUBE, air cleaner inlet (NL and B 40 km/h)	1	1	1
6	17253-081-000	TUBE, connecting, air cleaner	1	1	1
7	40220-093-000	ARM, crank, right	1	1	1
	40230-093-000	ARM, crank, left	1	1	1
8	40235-093-000	PIN, crank arm, setting	2	2	2
9	83600-117-000XL	COVER, engine (Ivory White)	1	1	1
10	90502-099-000	WASHER, plain, 6,5 mm X 18 X 15	3	3	3
11	28852-099-920	PEDAL ASSY (set L & R) (B-NL-F)	1	1	1
	28852-031-050	PEDAL ASSY (set L & R) (GB & DK) (Monobloc)	1	1	1
12	93500-06012	SCREW, pan 6 X 12	3	3	3
13	93500-06015	SCREW, pan, 6 X 15	1	1	1
14	93500-06018	SCREW, pan, 6 X 18	1	1	1
15	94001-06000	NUT, hex, 6 mm.	2	2	2
16	94101-06000	WASHER, plain, 6 mm.	4	4	4
17	17255-315-670	CLIP, air cleaner connect tube (used with new carburator)	1	1	1

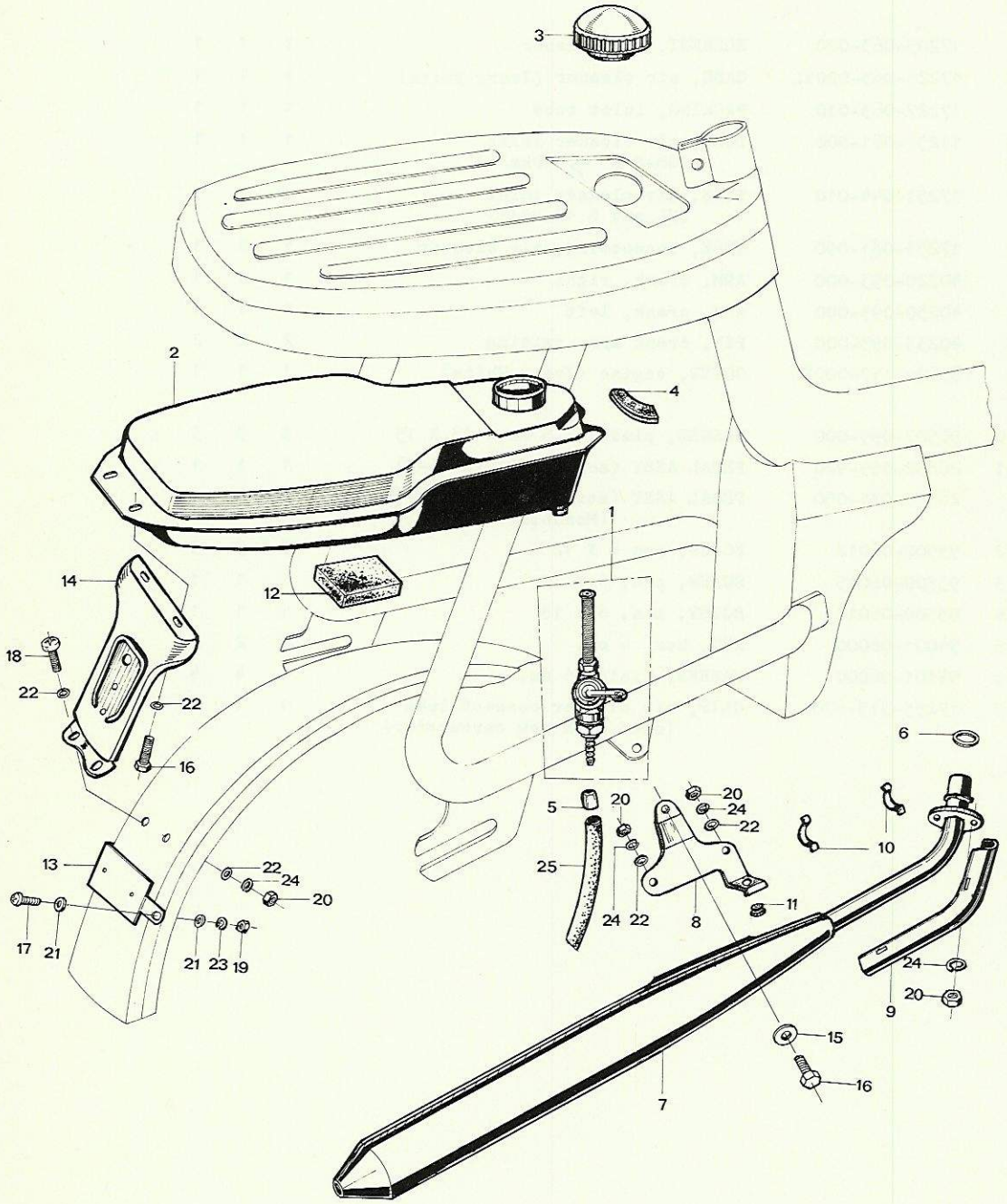

REF. N°.	PART N°.	DESCRIPTION	St.	R	NoR	REMARKS
G 1	16950-099-003	COCK, fuel assy	1	1	-	
	16950-099-159	COCK, fuel assy (F only)	1	-	-	
2	17500-099-010	FUEL TANK	1	1	-	see col.chart
3	17620-093-000	CAP, fuel filler	1	1	1	
4	17651-099-000	RUBBER, tank setting	1	1	-	
5	17722-099-000	CAP, fuel feed tube	2	2	2	
O 6	18291-099-000	GASKET, exhaust pipe	1	1	1	
7	18300-081-622	MUFFLER, comp. exhaust	1	1	1	
8	18351-099-020B	HANGER, muffler (Black)	1	-	-	
9	18400-081-020	COVER, exhaust pipe	1	1	1	
10	18401-063-000	CLIP, exhaust cover	2	2	2	
11	50524-023-000	RUBBER, mainstand stopper	1	-	-	
12	80121-099-000	CUSHION, fender rear	1	1	-	
13	84208-099-690XL	HOLDER, insurance plate (Ivory White) (NL)	1	-	-	
	84208-099-910XL	HOLDER, insurance plate (Ivory White) (NL)	-	1	1	
14	84701-099-010XL	PLATE, taillight (Ivory White) (B - NL - F)	1	-	-	
	84701-099-930XL	PLATE, taillight (Ivory White) (B - NL - F)	-	1	1	
15	90502-099-000	WASHER, plain, 6,5 X 18 X 1,5)	1	-	-	
16	92000-06015	BOLT, hex, 6 X 15 mm.	3	2	2	
17	93500-04012	SCREW, pan, 4 X 12 (NL only)	2	2	2	
18	93500-06012	SCREW, pan, 6 X 12	2	2	2	
19	94001-04000	NUT, hex, 4 mm. (NL)	2	2	2	
20	94001-06000	NUT, hex, 6 mm.	6	4	4	
21	94101-04000	WASHER, plain, 4 mm. (NL)	4	4	4	
22	94101-06000	WASHER, plain, 6 mm.	8	6	6	
23	94111-04000	WASHER, spring, 4 mm. (NL)	2	2	2	
24	94111-06000	WASHER, spring, 6 mm. (NL)	6	4	4	
25	95001-45450	TUBE, fuel 4,5 x 450	1	1	-	
	95001-45540	TUBE, fuel 4,5 x 540 (used with new carburator)	1	1	-	

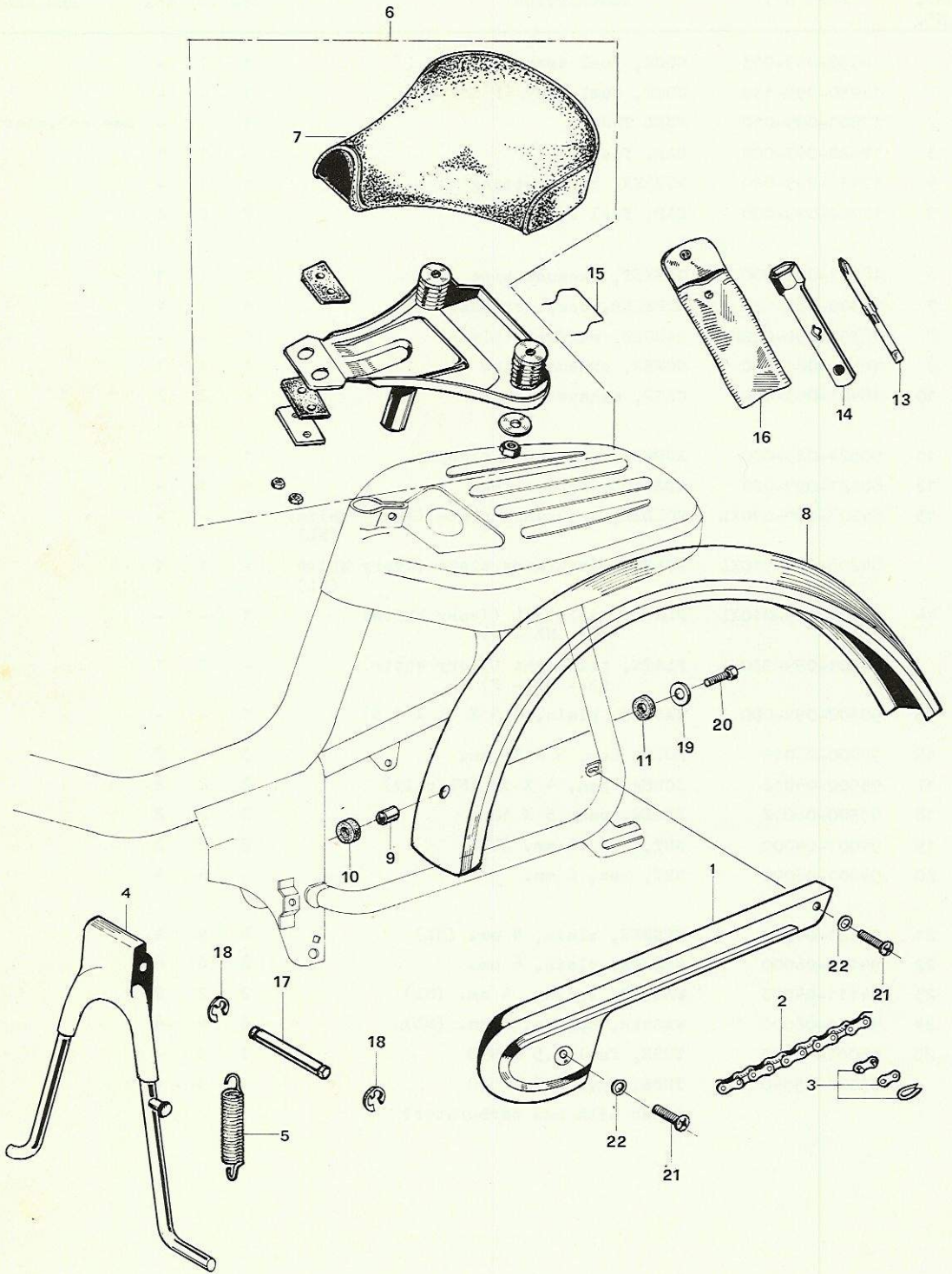

PF 50 F - 7

CHAINCASE - MAINSTAND - SEAT - REAR FENDER

REF. N°.	Part N°.	DESCRIPTION	St.	R	NoR	REMARKS
1	40510-099-000	CASE, drive chain	1	-	-	see col.chart
2	40530-099-690	CHAIN, drive (84 Links) (B & NL)	1	-	-	
	40530-099-620	CHAIN, drive (86 Links) (F & GB & DK)	1	-	-	
3	40531-099-003	JOINT, drive chain	1	7	1	
4	50500-099-010B	STAND MAIN (Black)	1	1	1	
5	50522-099-000	SPRING, mainstand	1	1	1	
6	77100-044-010	SADDLE ASSY	1	1	1	
7	77011-044-010	SEAT	1	1	1	
8	80100-099-010XL	FENDER, rear (Ivory White) (B-NL-F-GB)	1	-	-	
9	80111-099-000	COLLAR, distance rear fender	1	1	1	
10	80112-099-000	RUBBER A, rear fender	1	1	1	
11	80113-099-000	RUBBER B, rear fender	1	1	1	
12						
13	83513-044-000	DRIVER	1	1	1	
14	83517-063-000	WRENCH, spark plug	1	1	1	
15	83541-099-000	SPRING, toolbag fixing	1	1	1	
16	89101-063-000	BAG, tool	1	1	1	
17	90111-099-000	SHAFT, mainstand	1	1	1	
18	90300-099-000	CIRCLIP RS8	2	2	2	
19	90502-099-000	WASHER, plain, 6,5 X 18 x 15	1	1	1	
20	92000-06018	BOLT, hex, 6 X 18	1	1	1	
21	93500-06012	SCREW, pan, 6.X 12	2	2	2	
22	94101-06000	WASHER, plain, 6 mm.	2	2	2	

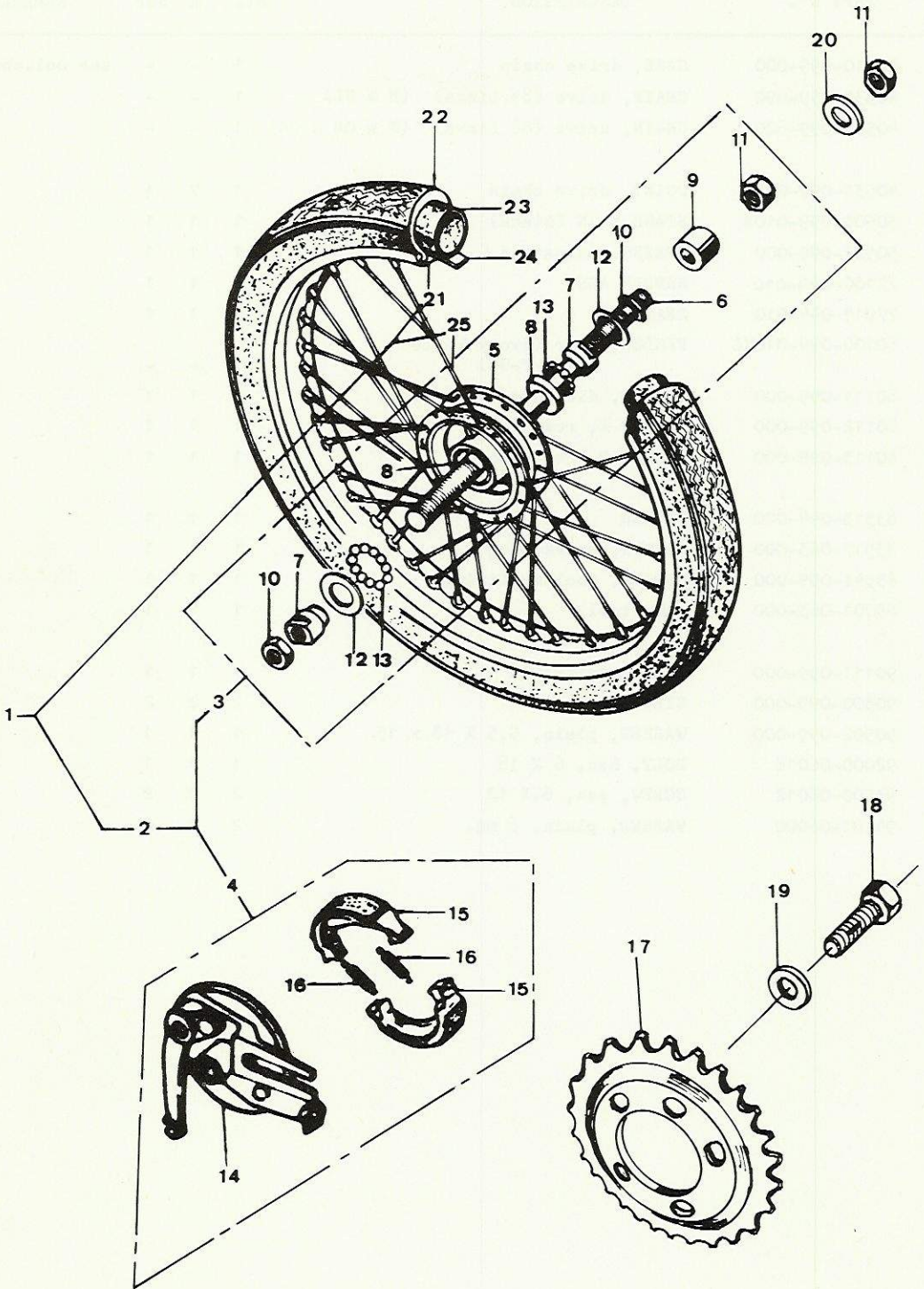



REF. No.	PART N°.	DESCRIPTION	St.	R	NoR	REMARKS
1	42600-099-000	WHEEL assy rear	1	1	1	n°1=2+21+25
0 2	42620-099-000	HUB and PANEL assy rear	1	1	1	n°2=3 + 4
3	42610-099-003	HUB assy rear	1	1	1	
0 4	43050-099-013	PANEL assy rear brake	1	1	1	
5	42601-099-003	HUB, rear wheel	1	1	1	
6	42301-099-003	AXLE, rear wheel	1	1	1	
7	42602-099-003	CCNE RACE, rear wheel	2	2	2	
8	42603-099-003	RACE BALL, rear wheel	2	2	2	
0 9	42315-099-003	COLLAR, distance rear axle	1	1	1	
10	90313-099-003	NUT, hex, thin 12 mm. (p.100)	2	2	2	
11	90315-099-003	NUT, hex, rear axle	3	3	3	
12	90505-099-003	WASHER, plain 29.1 X 0.2 th.	2	2	2	
13	96211-06000	BALL steel Ø 4.75	26	26	26	
14	43100-099-013	PANEL COMP., rear brake	1	1	1	
15	45120-093-003	SHOE COMP. brake	2	2	2	
16	45133-093-003	SPRING, brake shoe	2	2	2	
17	41201-099-690	SPROCKET, final driven 25 T (B & NL)	1	1	1	
	41201-099-010	SPROCKET, final driven 26 T (GB)	1	1	1	
	41201-099-620	SPROCKET, final driven 28 T (F & DK)	1	1	1	
18	90181-099-000	BOLT, self locking 6 X 16	5	5	5	
19	94101-06000	WASHER, plain 6 mm.	5	5	5	
20	94101-12000	WASHER, plain 12 mm.	2	2	2	
21	42701-122-690	RIM, wheel 17" rear	1	1	1	
22	44711-099-158	TIRE, wheel 21" x 2	1	1	1	
23	44712-099-158	TUBE, wheel 17"	1	1	1	
24	44713-099-158	FLAP, tire	1	1	1	
25	97524-21220	SPOKE, rear $\frac{11}{12}$	36	36	36	Nipple incl.

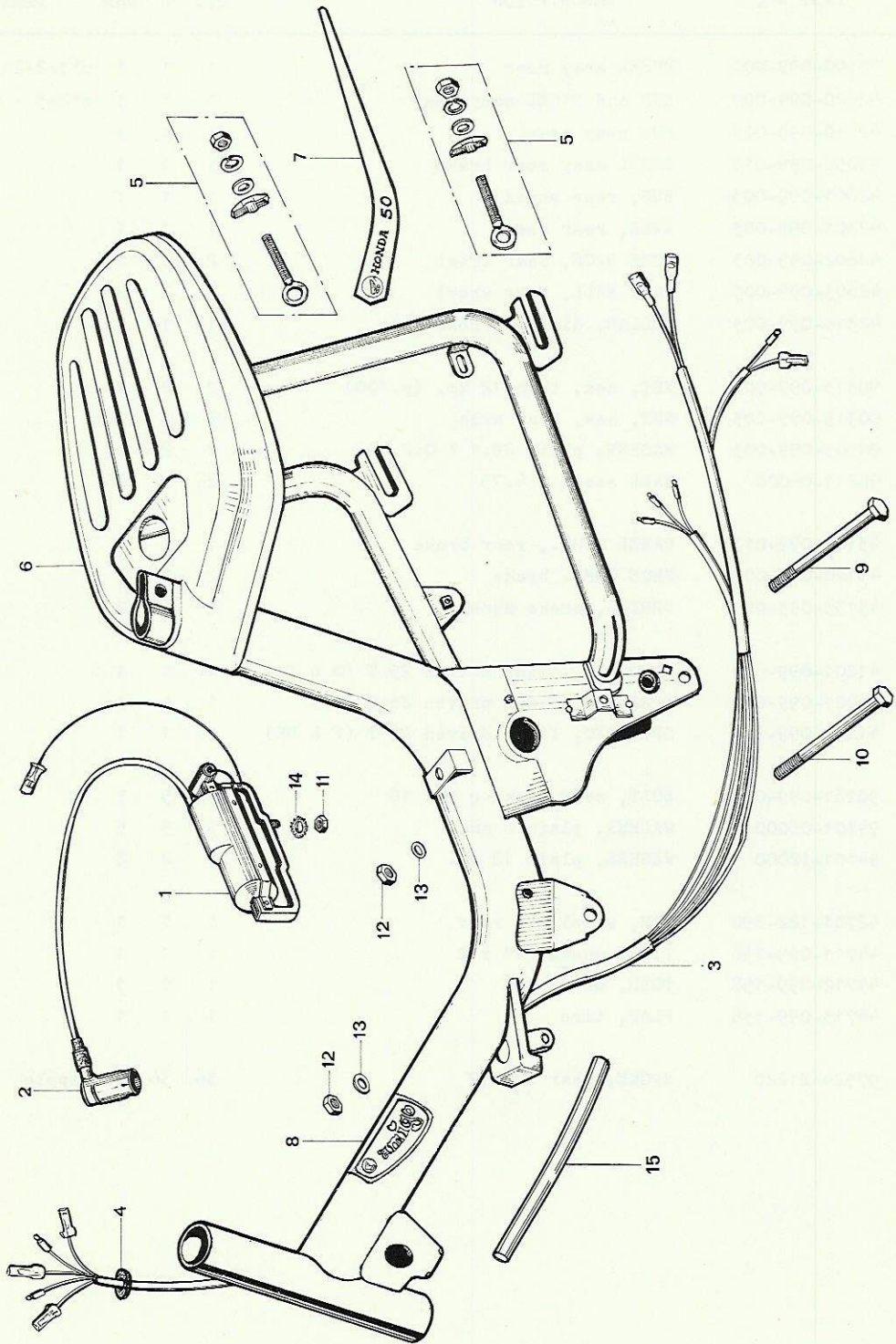

REF. N°.	PART N°.	DESCRIPTION	St.	R	NoR	REMARKS
1	30500-099-004	COIL, ignition	1	1	1	
2	30700-063-681	CAP, noise suppressor	1	1	1	
3	32100-099-000	HARNESS, wire (B & NL - F NoR)	1	1	1	
	32100-099-620	HARNESS, wire (F & DK)	1	-	-	
	32100-099-600	HARNESS, wire (GB)	1	1	1	
4	32983-063-000	GROMMET, wire cord	2	2	2	
5	40543-099-000	ADJUSTER, drive chain	2	2	2	
6	50100-099-000	BODY, comp. frame	1	-	-	see col. chart
7	87121-099-000	EMBLEM, right rear carrier	1	1	1	
	87181-143-000	EMBLEM, right rear carrier (F - RDX)	-	1	-	
	87122-099-000	EMBLEM, left rear carrier	1	1	1	
	87122-143-000	EMBLEM, left rear carrier (F - RDX)	-	1	-	
	87123-099-000	EMBLEM, frame (AMIGO) (B-NL-F)	1	1	-	
	87123-099-920	EMBLEM, frame (AMIGO) (F-RDX)	-	2	-	
9	92020-08080	BOLT, hex, 8 X 80	1	1	1	
10	92020-08090	BOLT, hex, 8 X 90	1	1	1	
11	94001-06000	NUT, hex, 6 mm.	1	1	1	
12	94001-08000	NUT, hex, 8 mm.	2	2	2	
13	94101-08000	WASHER, plain, 8 mm.	2	2	2	
14	94111-06000	WASHER, fan, 6 mm.	1	1	1	
15	91405-099-000	TUBE, cable cover	1	1	-	

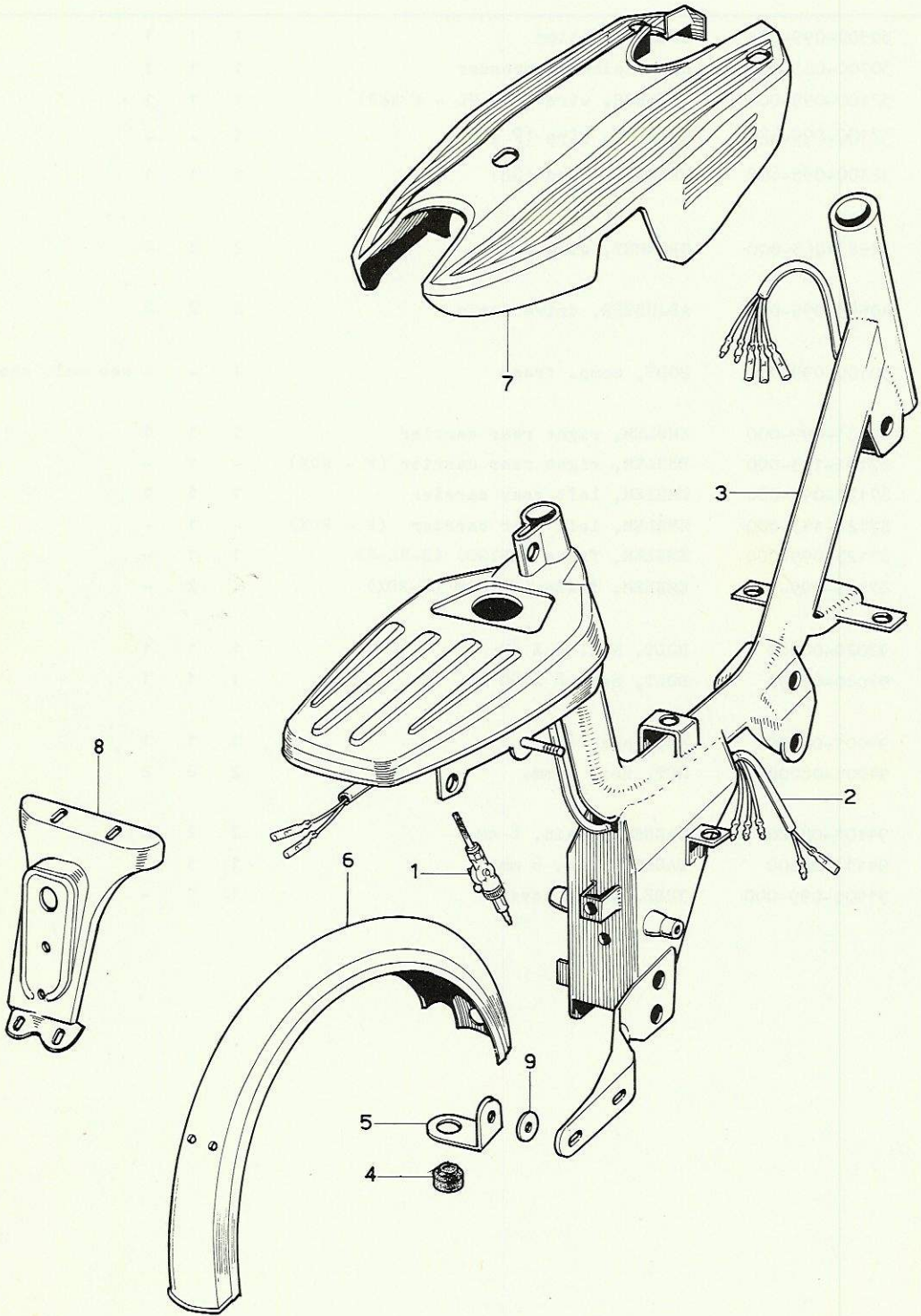

PF 50

F-10

FRAME BODY - REAR FENDER

REF. N°.	PART N°.	DESCRIPTION	St.	R	NoR	REMARKS
1	16950-099-003	COCK ASSY., fuel	1	1	-	
2	32100-099-000	HARNESS, wire (B & NL)	1	1	1	
	32100-099-600	HARNESS, wire (GB)	1	1	1	
	32100-099-620	HARNESS, wire (F & DK)	1	-	-	
3	50100-099-930	BODY COMP., frame	-	1	-	see colour
	50100-117-930	BODY COMP., frame	-	-	1	chart
4	50524-023-000	RUBBER, mainstand stopper	1	1	1	
5	50525-099-930	STAY, mainstand stopper	-	1	1	
6	80100-099-930XL	FENDER COMP., rear (Ivory White)	-	1	1	
7	83600-117-000XL	COVER, engine (Ivory White)	1	1	1	
8	84701-099-930XL	PLATE, taillight (Ivory White)	-	1	1	
9	90502-099-000	WASHER, plain 6,5 X 18 X 1,5	-	1	-	

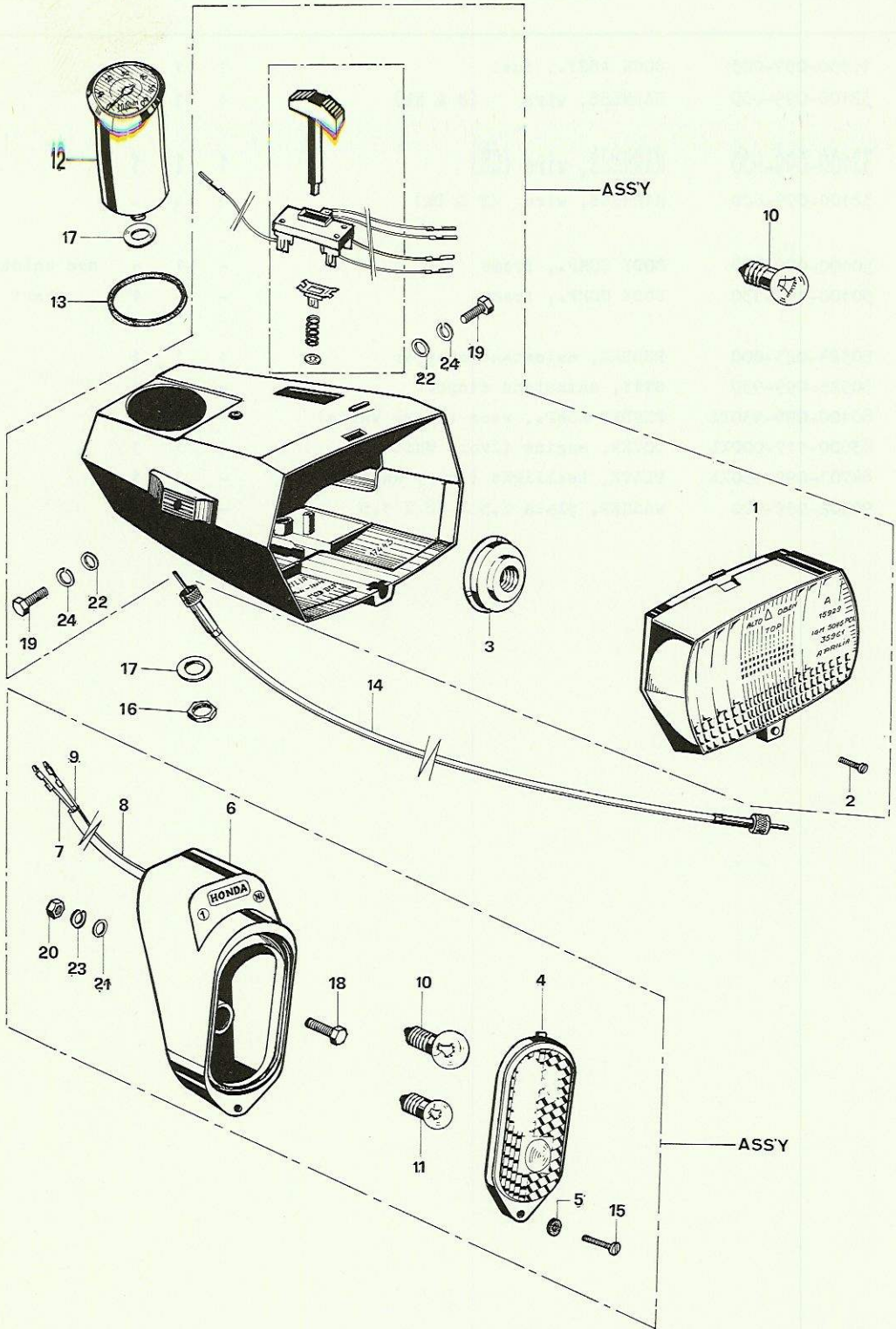

PF 50 F-11

## HEADLIGHT - TAILLIGHT (used in B - NL)

REF. N°	PART N°.	DESCRIPTION	St.	R	NoR	REMARKS
	33100-099-159	LIGHT ASSY., head (Aprilia) (used in B & NL.)	1	1	1	
1	33121-099-159	LENS, headlight	1	1	1	
2	33122-099-159	SCREW, lens headlight 3 X 12 mm.	1	1	1	
3	33130-099-159	SOCKET, headlight	1	1	1	
	33700-099-000	LIGHT ASSY., tail (B-NL-F)	1	1	1	
4	33701-064-621	LENS, taillight (B-NL-F)	1	1	1	
5	33702-064-620	PACKING, taillight lens	1	1	1	
6	33705-064-690	BODY, taillight	1	1	1	
7	33708-099-000	CORD, taillight	1	1	1	
8	33709-094-000	TUBE, taillight cord	1	1	1	
9	33712-099-000	CORD, stoplight	1	1	1	
10	34901-063-690	BULB, headlight (6V-6W) (used in B & NL.)	2	2	2	(Head & stop- light)
11	34906-093-000	BULB, taillight (10V-0,32A)	1	1	1	
12	37200-099-003	SPEEDOMETER (km/h.) (used in B-NL-F)	1	1	1	
13	37202-099-000	JOINT, speedometer	-	1	-	
14	44830-099-003	CABLE, speedometer	1	1	1	
15	90131-093-000	SCREW, tapping 3 X 13 mm.	1	1	1	
16	90310-099-003	NUT, thin, speedometer setting	1	1	1	
17	90548-099-003	WASHER, plain 10 mm.	2	2	2	
18	92000-05012	BOLT, hex, 5 X 12	1	1	1	
19	92000-06020	BOLT, hex, 6 X 20	2	2	2	
20	94001-05000	NUT, hex, 5 mm.	1	1	1	
21	94101-05000	WASHER, plain 5 mm.	1	1	1	
22	94101-06000	WASHER, plain 6 mm.	2	2	2	
23	94111-05000	WASHER, spring 5 mm.	1	1	1	
24	94111-06000	WASHER, spring 6 mm.	2	2	2	

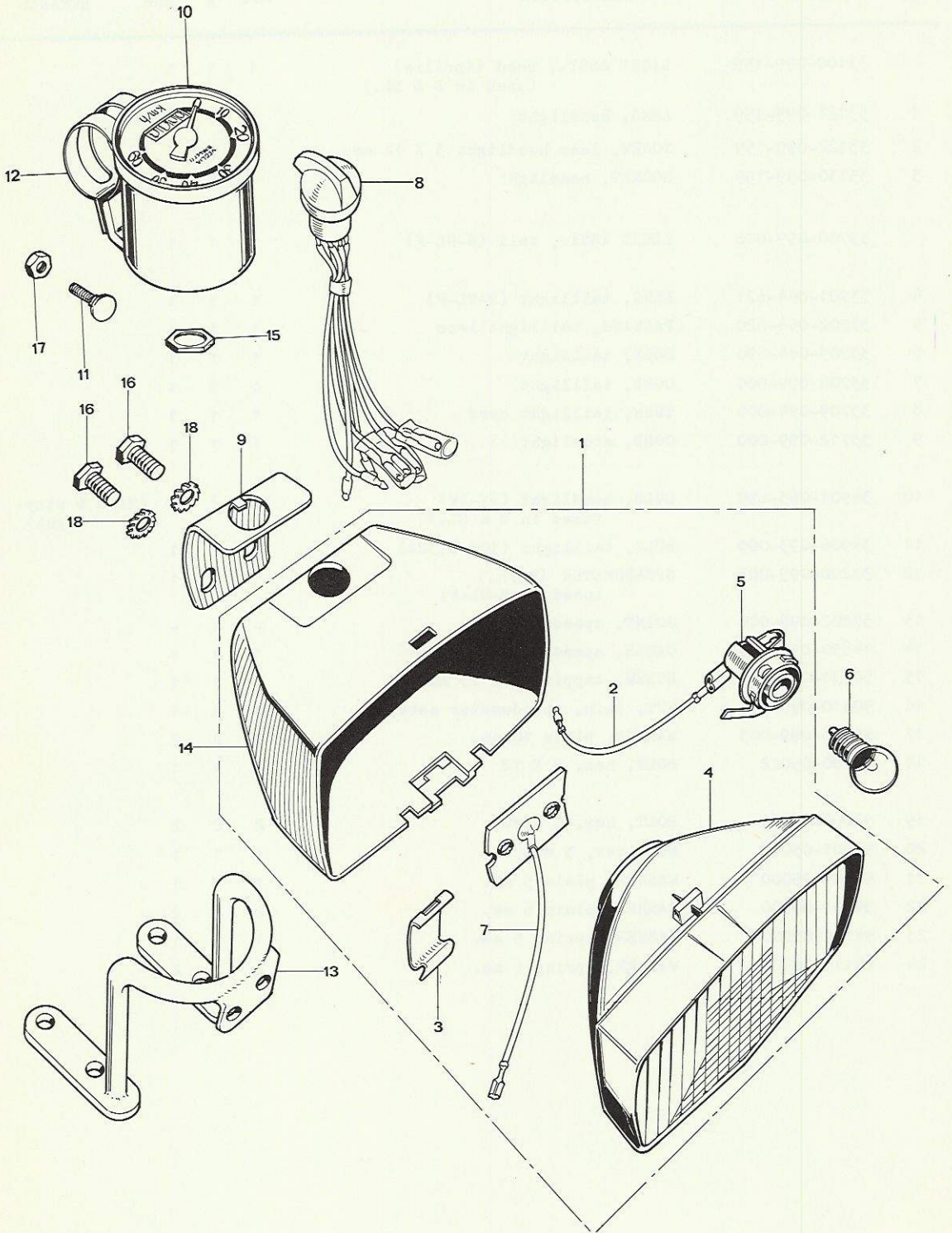



PF 50 F - 12

## HEADLIGHT (used in B - NL - F - DK)

REF. N <sup>o</sup> .	PART N <sup>o</sup> .	DESCRIPTION	St.	R	NoR	REMARKS
1	33100-099-930	LIGHT ASSY, head (Soubitez)(B & NL) (F-DK/R type)	1	1	1	
2	33105-094-620	CORD, switch headlight	1	1	1	
3	33108-099-620	CLAMP, lens setting	1	1	1	
4	33121-099-621	LENS, headlight	1	1	1	
5	33130-099-620	SOCKET, headlight	1	1	1	
6	34901-050-621	BULB, headlight (6V-6W) (F)	-	1	-	
	34901-063-690	BULB, headlight (6V-6W) (B & NL & DK)	1	1	1	
7	34902-099-620	EARTH, headlight	1	1	1	
8	35100-099-690	SWITCH ASSY, lighting	1	1	1	
9	35110-094-620XL	PLATE, switch lighting setting (Ivory White)	1	1	1	
10	37200-117-620	SPEEDOMETER ASSY (km/h.)	1	1	1	
11	37203-117-620	SCREW, speedometer assy	1	1	1	
12	37210-117-620	HOLDER, speedometer setting	1	1	1	
13	51516-099-621	STAY, headlight	1	1	1	
14 <sup>o</sup>						
15	90310-099-003	NUT, thin, speedometer	1	1	1	
16	92000-06012	BOLT, hex, 6 X 12	2	2	2	
17	94001-04000	NUT, hex, 4 mm.	1	1	1	
18	94111-06000	WASHER, fan, 6 mm.	2	2	2	

<sup>o</sup> Not available separately

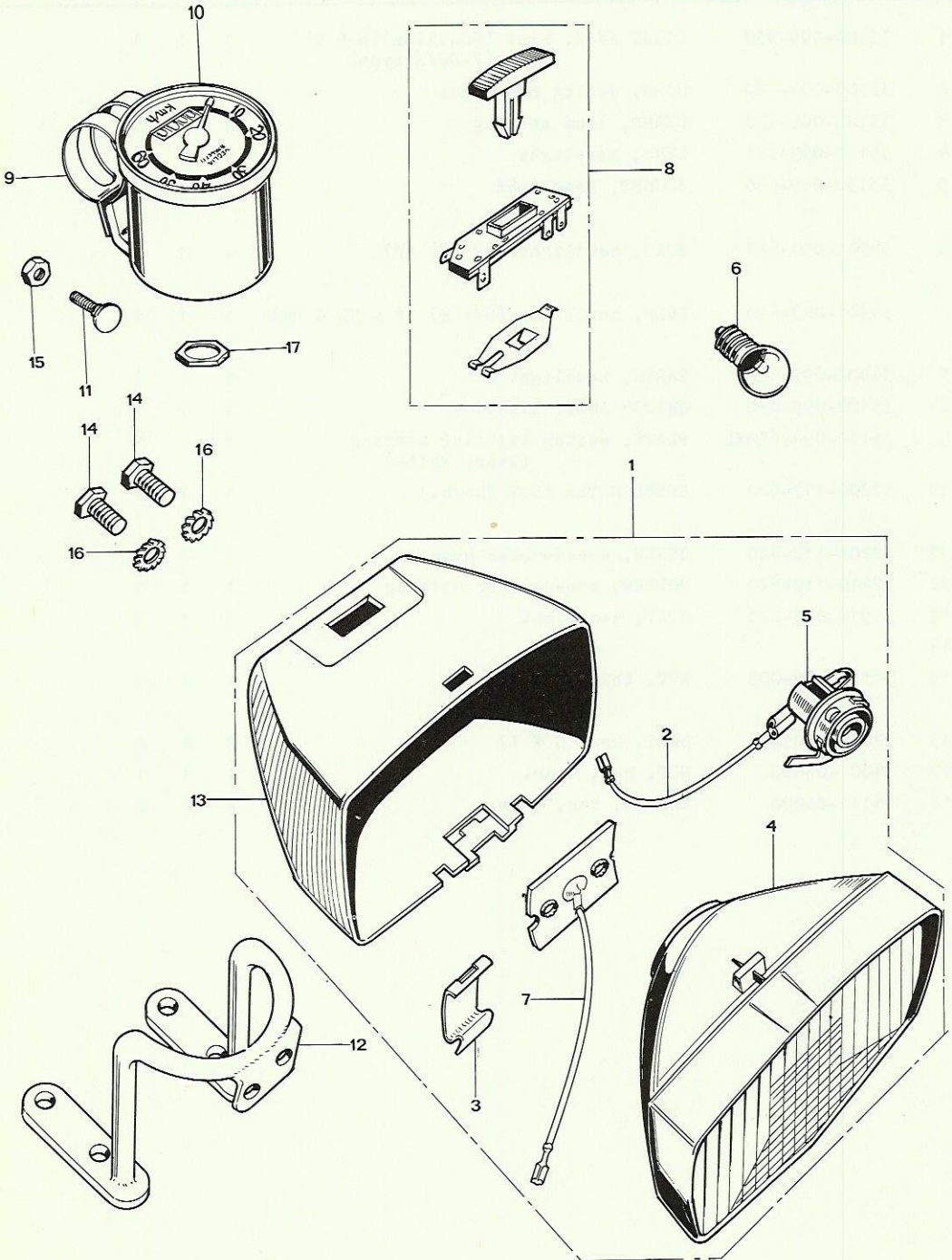

REF. N°.	PART N°.	DESCRIPTION	St.	R	NoR	REMARKS
1	33100-099-621	LIGHT ASSY, head (Soubitez)	1	-	-	
2	33105-099-620	CORD, switch headlight	1	-	-	
3	33108-099-620	CLAMP, lens setting	1	-	-	
4	33121-099-621	LENS, headlight	1	-	-	
5	33130-099-620	SOCKET, headlight	1	-	-	
6	34901-063-690	BULB, headlight (6V-6W) (DK)	1	-	-	
	34901-050-621	BULB, headlight (6V-6W) (F)	1	-	-	
7	34902-099-620	EARTH, headlight	1	-	-	
8	35100-099-620	SWITCH ASSY, lighting	1	-	-	
9	37210-117-620	HOLDER, speedometer setting	1	-	-	
10	37200-117-620	SPEEDOMETER ASSY, (km/h.)	1	-	-	
11	37203-117-620	SCREW, speedometer assy	1	-	-	
12	51516-099-621	STAY, headlight	1	-	-	
13°						
14	92000-06012	BOLT, hex, 6 X 12	2	-	-	
15	94001-04000	NUT, hex, 4 mm.	1	-	-	
16	94111-06000	WASHER, fan, 6 mm.	2	-	-	
17	90310-099-003	NUT, thin, speedometer	1	-	-	

° Not available separately

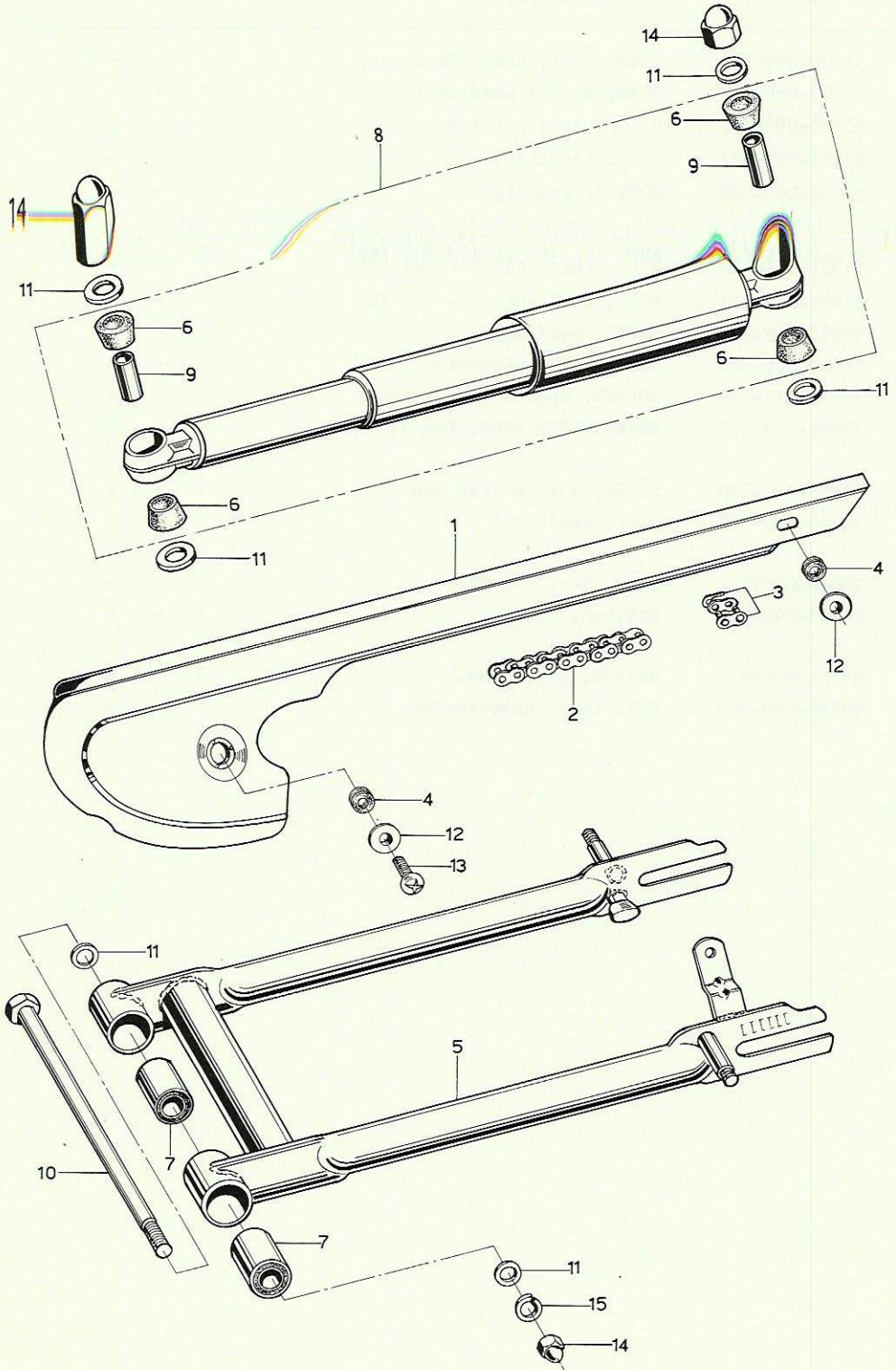

PF 50 F - 14

REAR CUSHION - CHAIN CASE

REF. N°	PART N°.	DESCRIPTION	St.	R	NoR	REMARKS
1	40510-099-930	CASE, drive chain	-	1	1	see col.chart
2	40530-099-930	CHAIN, drive (88 Links)	-	1	1	B-NL-GB
	40530-099-680	CHAIN, drive (90 Links)	-	1	1	F-DK
3	40531-099-003	JOINT, drive chain	-	1	1	
4	40618-099-930	RUBBER, chain case setting	-	2	2	
5	52100-099-930	FORK COMP. , rear	-	1	1	see col.chart
6	52144-027-000	BUSHING, rubber rear cushion	-	8	8	
7	52181-023-300	BUSHING, rear fork pivot rubber	-	2	2	
8	52400-099-930	CUSHION ASSY., rear	-	2	2	see col.chart
9	52485-093-000	COLLAR, rear cushion upper	-	4	4	
10	90121-063-000	BOLT, rear fork pivot	-	4	4	
11	90401-099-930	WASHER, bolt rear fork pivot setting	-	10	10	
12	90543-099-930	WASHER, CUP, chain case setting	-	2	2	
13	93500-06012	SCREW, pan 6 X 12	-	2	2	
14	94022-10000	NUT, blind 10 mm.	-	5	5	
15	94111-10000	WASHER, spring 10 mm.	-	1	1	

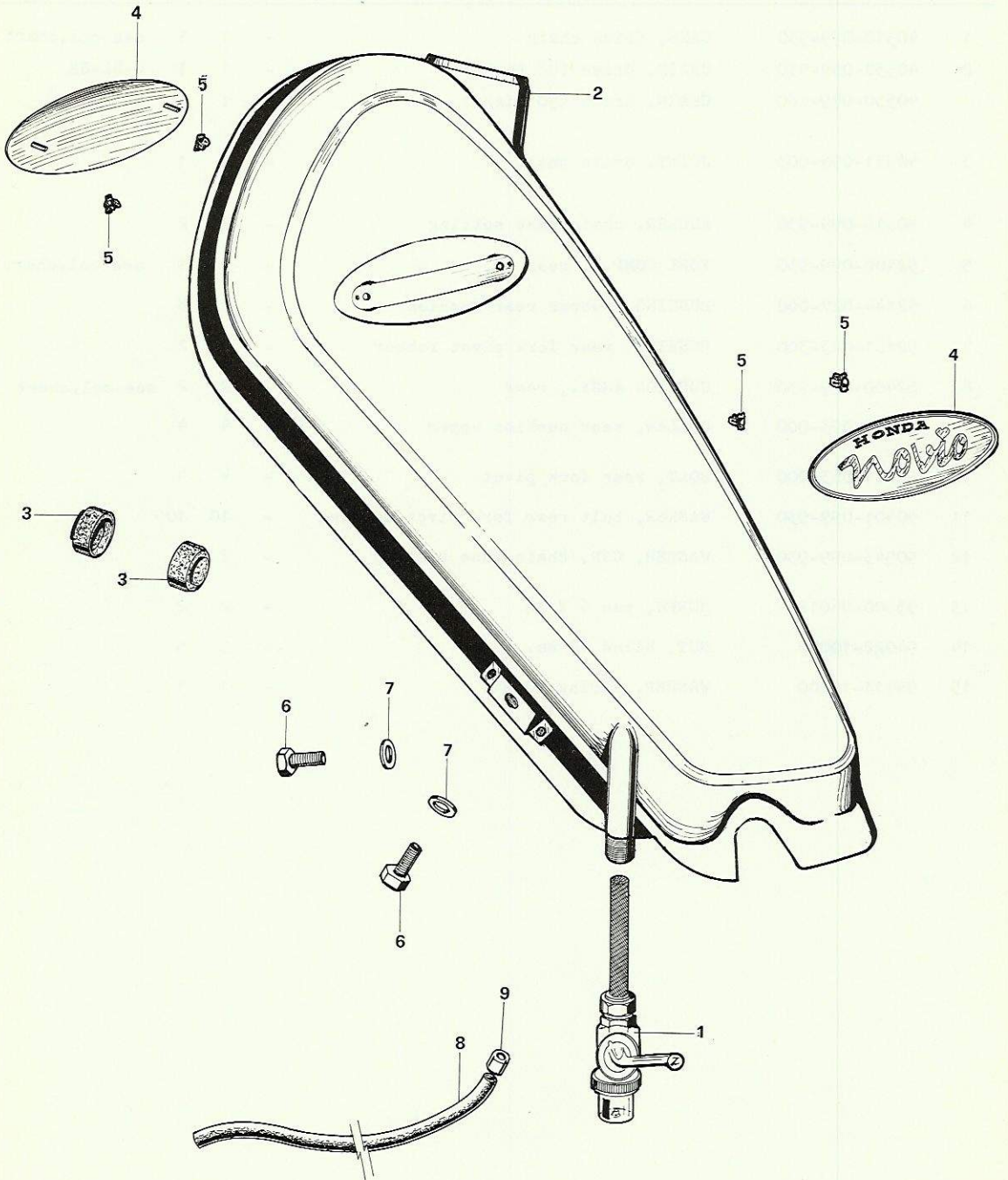

REF. N°	PART N°.	DESCRIPTION	St.	R	NoR	REMARKS
1	16950-117-003	COCK ASSY, fuel	-	-	1	
2	17500-117-000	TANK, fuel	-	-	1	see col.chart
3	17611-117-000	CUSHION, fuel tank front	-	-	2	
4	87123-117-000	EMBLEM, fuel tank	-	-	2	
5	87311-516-000	NUT CLAMP, rear ornament	-	-	4	
6	92000-06012	BOLT, hex, 6 X 12	-	-	2	
7	94101-06000	WASHER, plain, 6 mm.	-	-	2	
8	95001-45140	TUBE, fuel 4,5 X 140	-	-	1	
9	17722-099-000	CAP, fuel feed tube	-	-	2	

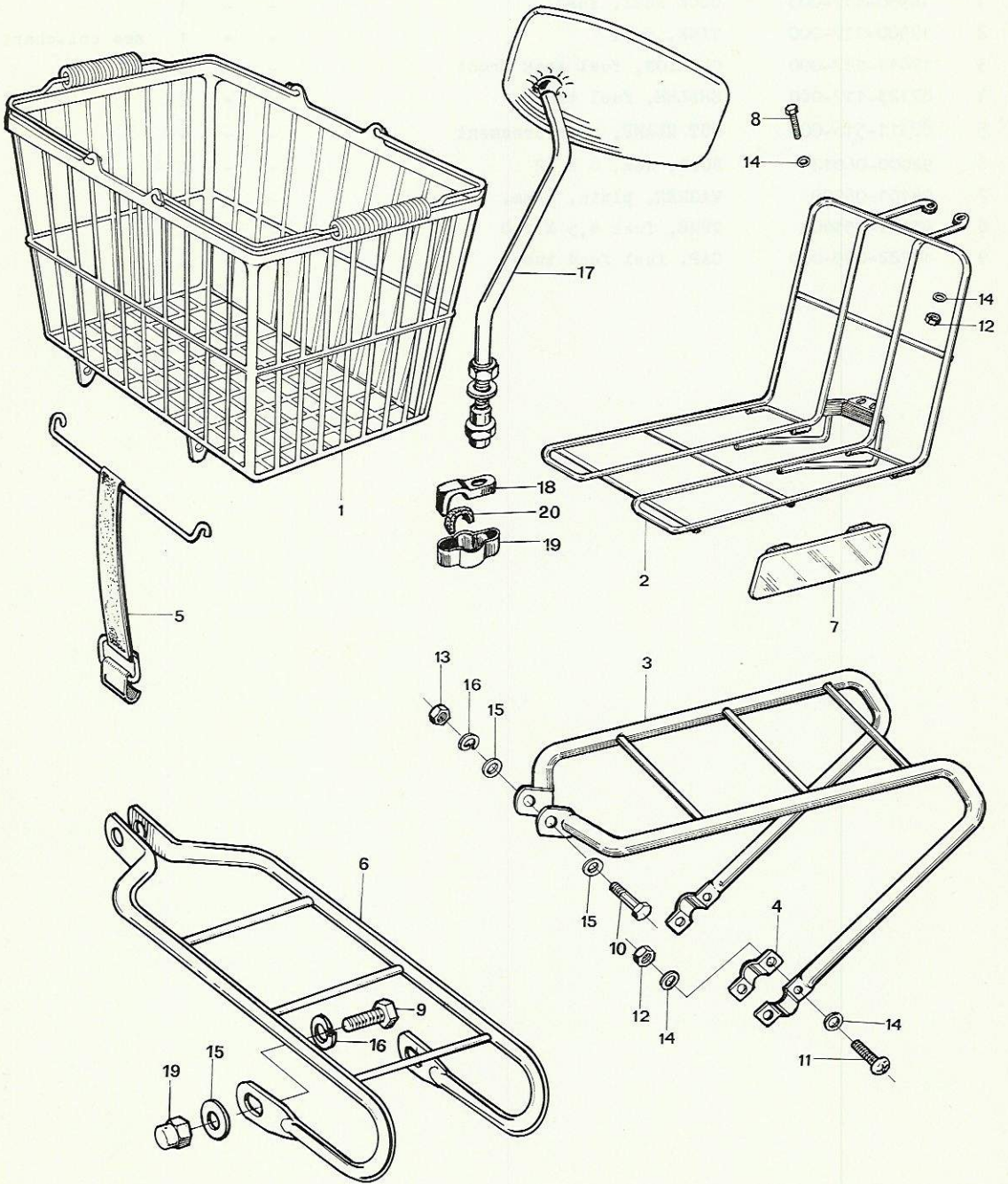



REF. N°	PART N°.	DESCRIPTION	St.	R	NoR
1	08101-093999	BASKET	1	1	1
2	81200-093-000	CARRIER, front	1	1	1
3	81200-099-890	CARRIER, rear	1	-	-
4	81201-099-890	BRACKET, rear carrier setting	2	-	-
5	81221-044-811	HOOK, A, basket	1	1	1
6	81200-099-930XW	CARRIER, rear (chromed)	-	1	1
7	87900-044-690	PLATE, ornament right (NL-mach.with front carrier)	1	1	1
	87900-044-690	PLATE, ornament left (NL-mach. with front carrier)	1	1	1
8	92000-06012	BOLT, hex., 6 X 12	2	2	2
9	92000-08015	BOLT, hex, 8 X 15	-	2	2
10	92000-08025	BOLT, hex, 8 X 25 (used for mach. without carrier)	1	1	1
	92000-08032	BOLT, hex, 8 X 32 (used for machines with carrier)	1	1	1
11	93500-06018	SCREW, pan, 6 X 18	4	-	-
12	94001-06000	NUT, hex, 6 mm.	6	2	2
13	94001-08000	NUT, hex, 8 mm.	1	1	1
14	94101-06000	WASHER, plain, 6 mm.	8	4	4
15	94101-08000	WASHER, plain, 8 mm.	2	4	4
16	94022-08000	NUT, blind, 8 mm.	-	2	2
17	88120-011-810	MIRROR, back, left	1	1	1
18	88131-011-020	BRACKET, back mirror upper	1	1	1
19	88132-011-020	BRACKET, back mirror under	1	1	1
20	88191-011-000	PACKING, back mirror	2	2	2

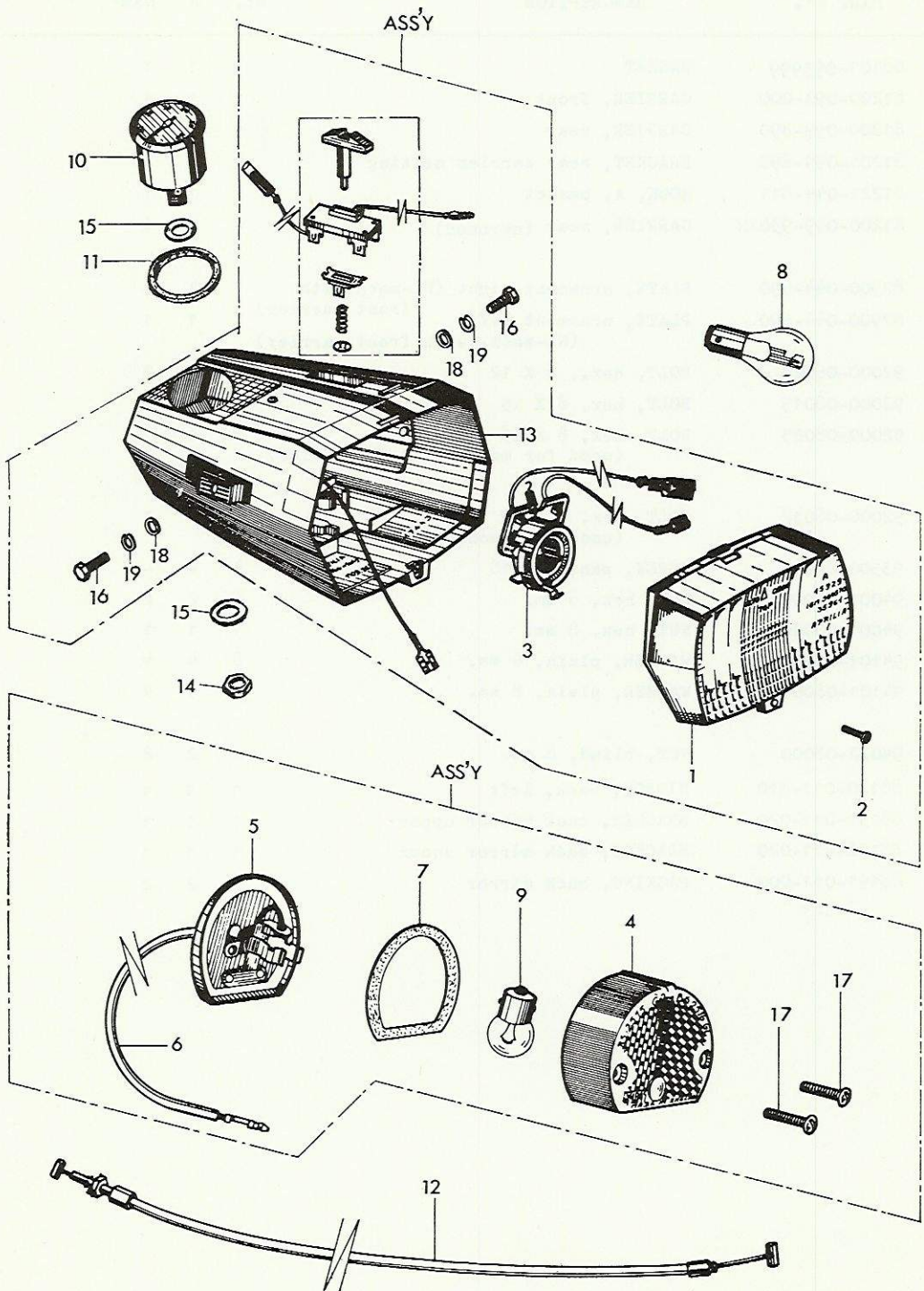

REF. N°.	PART N°.	DESCRIPTION	St.	R	NoR	SERIE N°.
	33100-099-600	LIGHT, assy head (Aprilia)	1	1	1	No bulb
1	33121-099-600	LENS, headlight	1	1	1	
2	33122-099-159	SCREW, lens headlight 3 X 12 mm.	1	1	1	
3	33130-099-600	SOCKET, headlight	1	1	1	
	33700-099-601	LIGHT, assy tail (Wipac)	1	1	1	Assy + bulb
4	33701-099-601	LENS, taillight	1	1	1	-A44268
5	33705-099-600	PLATE, taillight lens holder	1	1	1	
6	33708-099-600	CORD, taillight	1	1	1	
7	33709-099-600	PACKING, lens taillight	1	1	1	
8	34901-001-812	BULB, headlight (6V 15/15W)	1	-	-	A16210/A61346
	34901-099-600	BULB, headlight (6V 18/18W)	1	1	1	-A61347
9	34906-099-600	BULB, taillight (6V 6W)	1	1	1	
10	37200-143-600	SPEEDOMETER, Mile/h.	1	1	1	
11	37202-099-920	JOINT, speedometer	1	1	1	
12	43450-099-680	CABLE, rear brake (without stop sw.)	1	-	-	A16210/A71047
	43450-099-681	CABLE, rear brake (without stop sw.)	1	1	1	-A71048
13°						
14	90310-099-003	NUT, thin speedometer	1	1	1	
15	90548-099-003	WASHER, plain 10 mm.	2	2	2	
16	92000-06020	BOLT, hex, 6 X 20	2	2	2	
17	93500-05022	SCREW, pan head 5 X 22	2	2	2	
18	94101-06000	WASHER, plain, 6 mm.	2	2	2	
19	94111-06000	WASHER, spring, 6 mm.	2	2	2	

° Not available separately

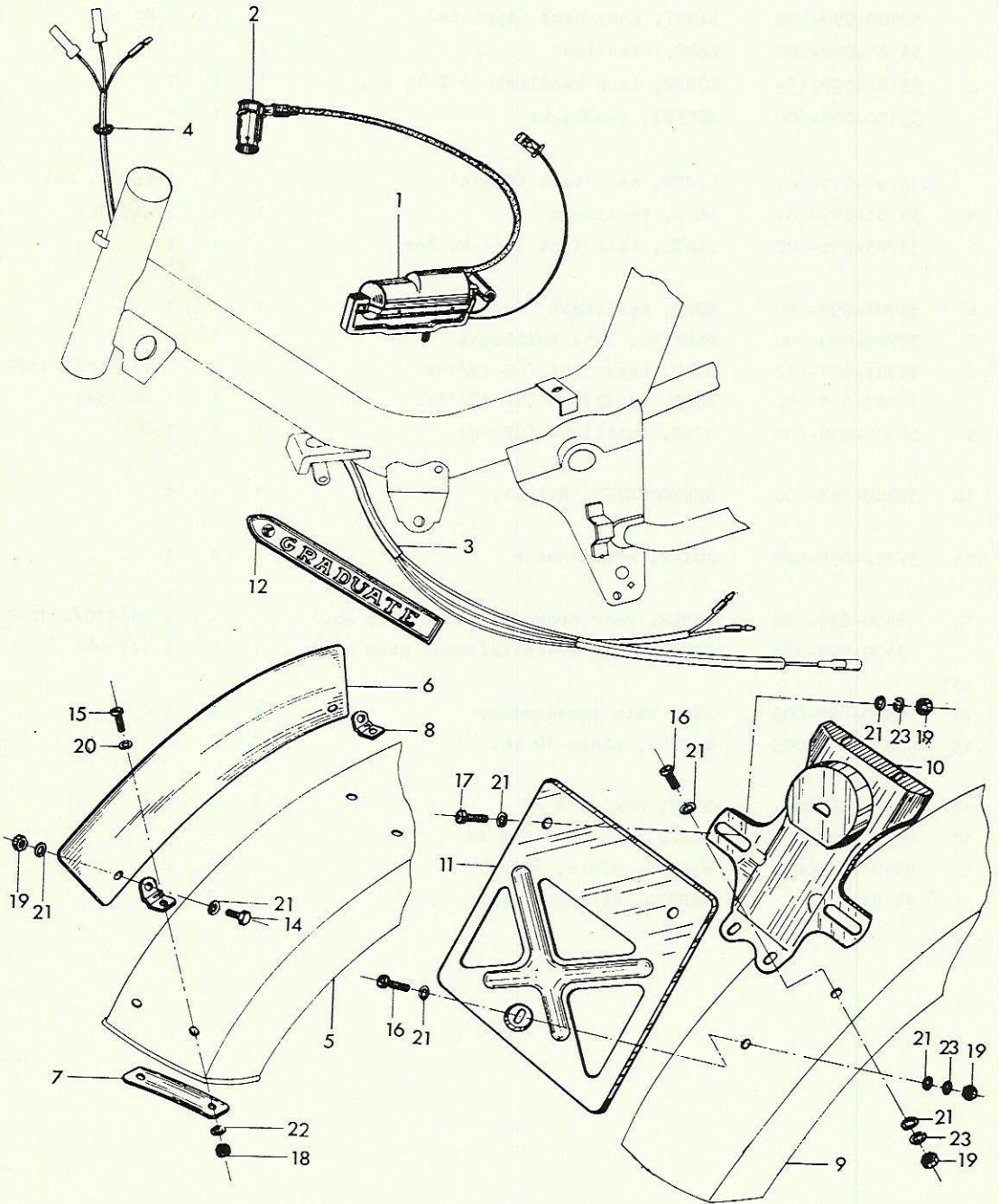

REF. N°.	PART N°.	DESCRIPTION	St.	R	NoR	REMARKS
1	30500-099-004	COIL IGNITION	1	1	1	
2	30700-063-681	CAP, assy noise suppressor	1	1	1	
3	32100-099-600	HARNESSE, wire (GB)	1	1	1	
4	32983-063-000	GROMMET, wire cord	2	2	2	
5	61100-099-600CB	FENDER, front (Cambridge blue)	1	-	-	
	61100-099-600XL	FENDER, front (Ivory White)	1	1	1	
	61130-099-600	NUMBER PLATE, front comp. (comp.set)	1	1	1	
6°		NUMBER PLATE, front	1	1	1	
7°		WASHER, number plate setting	2	2	2	
8°		BRACKET, front, number plate	4	4	4	
9	80100-099-600CB	FENDER, rear (Cambridge Blue)	1	-	-	
	80100-099-600XL	FENDER, rear (Ivory White)	1	-	-	
	80100-099-900XL	FENDER, rear (Ivory White)	-	1	1	
	84701-099-600B	BRACKET A, number plate (Black)	1	1	1	
11	84702-099-600B	BRACKET B, number plate (Black)	1	1	1	
12	87123-099-600	EMBLEM, frame R/H	1	1	-	
	87124-099-600	EMBLEM, frame L/H	1	1	-	
13°						
14	92000-06012	BOLT, hex, 6 X 12	2	2	2	
15	93500-04012	SCREW, cross, 4 X 12	4	4	4	
16	93500-06012	SCREW, pan head, 6 X 12	3	3	3	
17	93500-06015	SCREW, pan head, 6 X 15	2	2	2	
18	94001-04000	NUT, hex, 4 mm.	4	4	4	
19	94001-06000	NUT, hex, 6 mm.	7	7	7	
20	94101-04000	WASHER, plain, 4 mm.	4	4	4	
21	94101-06000	WASHER, plain, 6 mm.	14	14	14	
22	94111-04000	WASHER, spring, 4 mm.	4	4	4	
23	94111-06000	WASHER, spring, 6 mm.	5	5	5	

° Not available separately

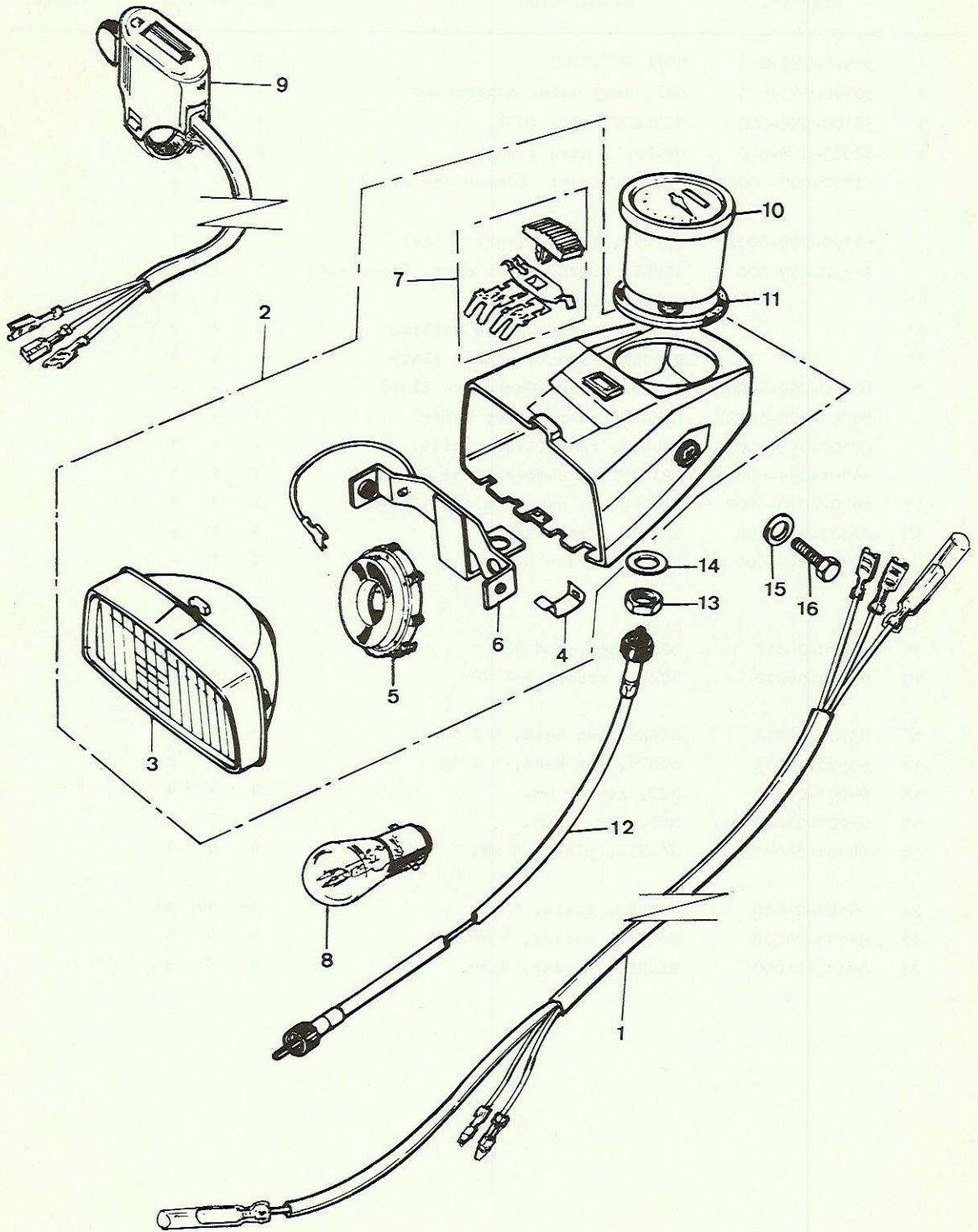

REF. N°	PART N°	DESCRIPTION	St.	R	NoR	REMARKS
1	32100-143-600	WIRING HARNESS	-	-	1	
2	33100-143-600	LIGHT ASSY, head (Soubitez)	-	-	1	
3	33121-143-600	LENS, headlight	-	-	1	
4	33108-099-620	CLAMP, lens setting	-	-	1	
5	33130-143-600	SOCKET, headlight	-	-	1	
6	34902-122-690	EARTH, headlight	-	-	1	
7	35100-143-600	SWITCH ASSY, lighting	-	-	1	
8	34901-099-600	BULB, headlight (6V-18/18W)	-	-	1	
9	35300-143-603	SWITCH ASSY, dimmer	-	-	1	
10	37200-143-600	SPEEDOMETER ASSY (Mile/h.)	-	-	1	
11	37202-099-920	JOINT, speedometer	-	-	1	
12	44830-099-003	CABLE, speedometer	-	-	1	
13	90310-099-003	NUT, thin speedometer setting	-	-	2	
14	90548-099-003	WASHER, plain, 10 mm.	-	-	1	
15	94101-06000	WASHER, plain, 6 mm.	-	-	2	
16	92000-06022	BOLT, hex, 6 X 22	-	-	2	

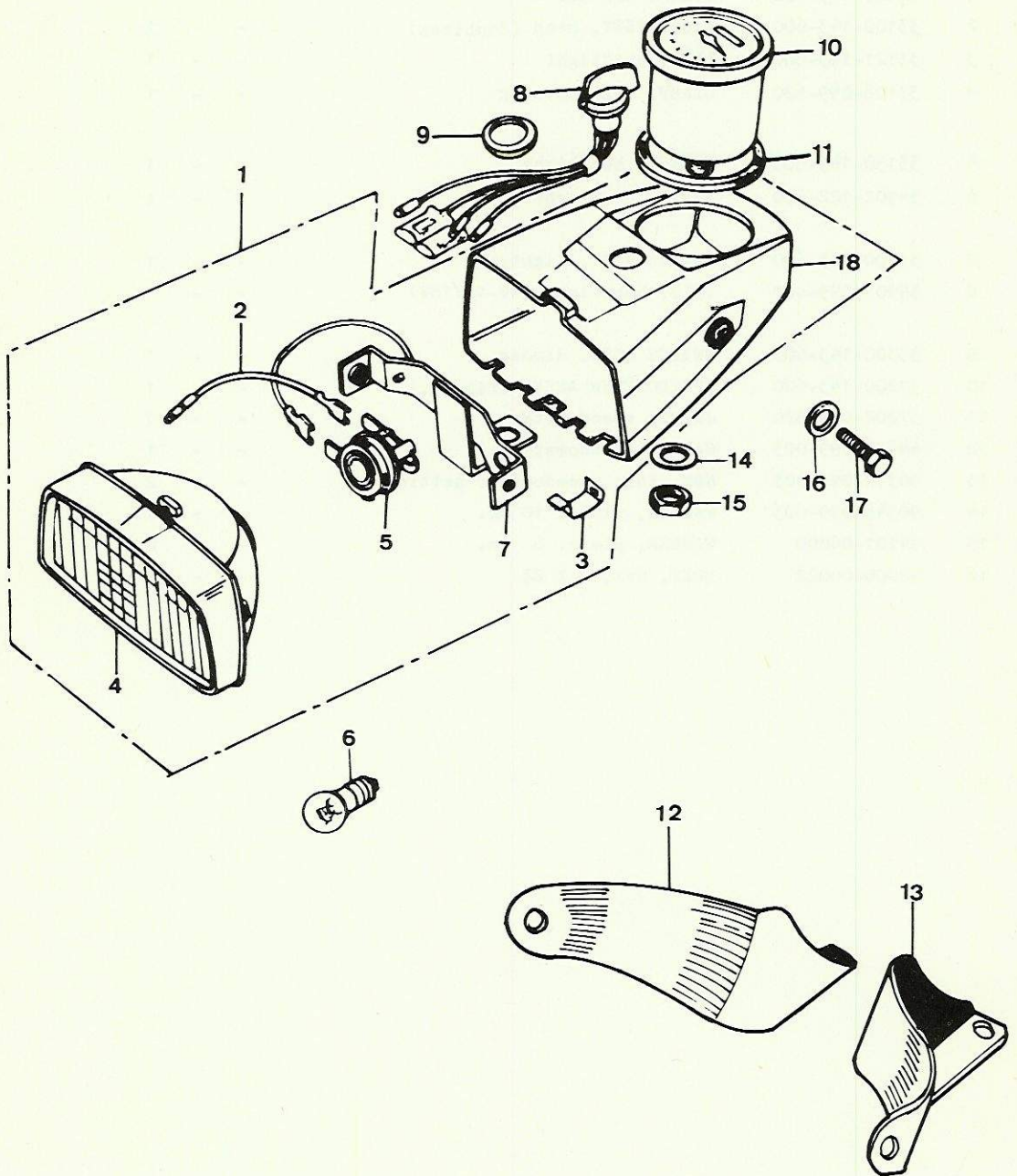



# HONDA

PF 50

F - 20

## HEADLIGHT (used in B - NL - F (RDX))

REF. N°.	PART N°.	DESCRIPTION	St.	R	NoR	REMARKS
1	33100-122-690XL	LIGHT ASSY, head (Ivory White) (B - NL - F (RDX))	1	1	1	
2	33105-094-620	CORD, switch headlight	1	1	1	
3	33108-099-620	CLAMP, lens setting	1	1	1	
4	33121-099-621	LENS, headlight	1	1	1	
5	33130-099-620	SOCKET, headlight	1	1	1	
6	34901-050-621	BULB, headlight (6V-6W) F (RDX)	1	1	1	
	34901-063-690	BULB, headlight (6V-6W) (B & NL)	1	1	1	
7	34902-122-690	EARTH, headlight	1	1	1	
8	35100-099-690	SWITCH ASSY, lighting	1	1	1	
9	90514-122-690	WASHER, switch headlight	1	1	1	
10	37200-099-920	SPEEDOMETER ASSY (V.D.O.)	1	1	1	
11	37202-099-920	JOINT speedometer (V.D.O.)	1	1	1	
12	51516-093-000	STAY, headlight, right	1	1	1	
13	51517-093-000	STAY, headlight, left	1	1	1	
14	90548-099-003	WASHER, plain, 10 mm.	1	1	1	
15	90310-099-003	NUT, thin, speedometer	1	1	1	
16	94101-06000	WASHER, plain 6 mm.	2	2	2	
17	92000-06022	BOLT, hex, 6 X 22	2	2	2	
18°	61301-122-690XL	CASE, headlight (Ivory White)	1	1	1	

° Not available separately

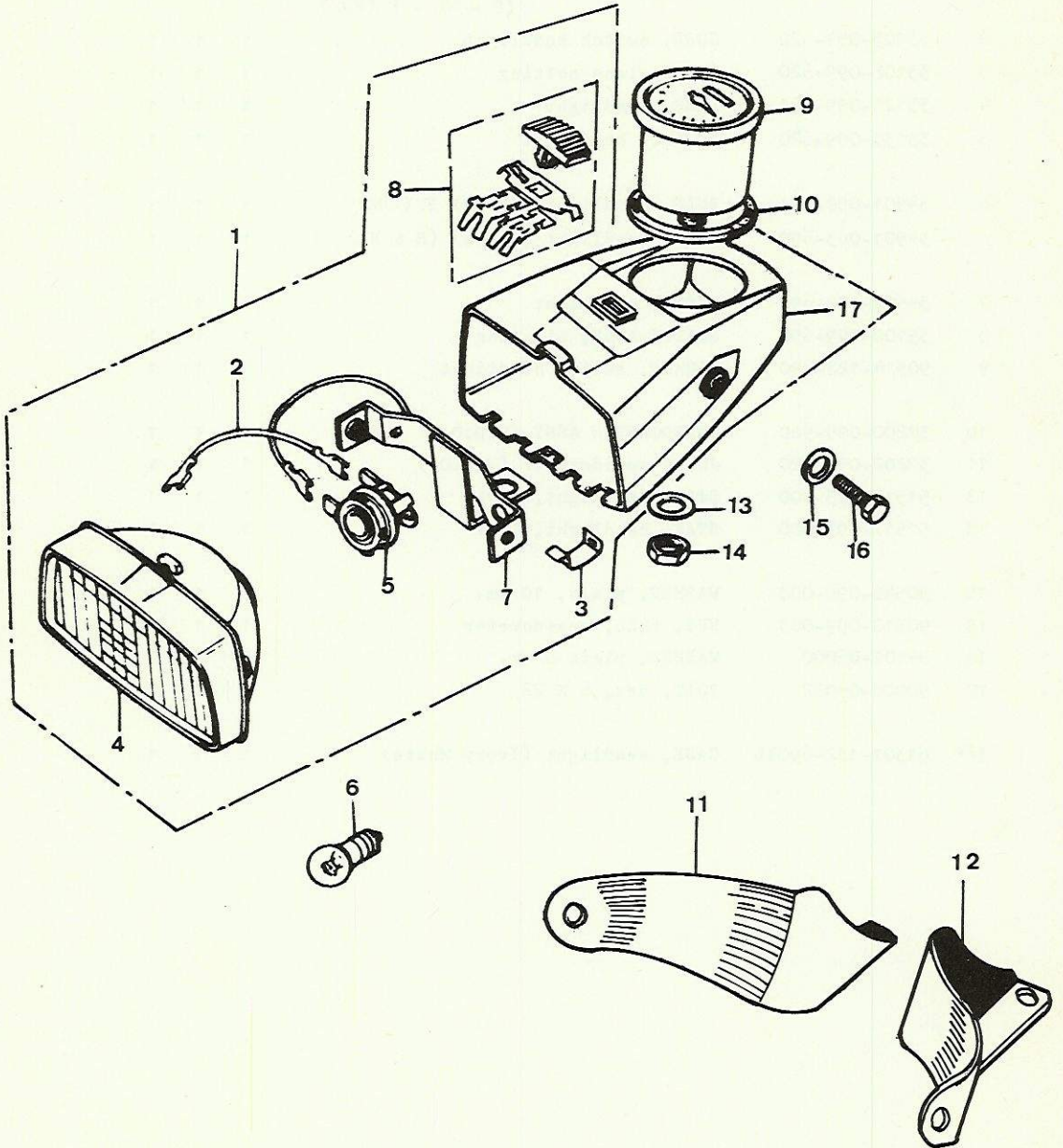

PF 50

F - 21

HEADLIGHT (used in F - DK)

REF. N <sup>o</sup> .	PART N <sup>o</sup> .	DESCRIPTION	St.	R	NoR	REMARKS
1	33100-099-003XL	LIGHT ASSY, head (Ivory White) (F-DK)	1	-	-	
2	33105-099-620	CORD, switch headlight	1	-	-	
3	33108-099-620	CLAMP, lens setting	1	-	-	
4	33121-099-621	LENS, headlight	1	-	-	
5	33130-099-620	SOCKET, headlight	1	-	-	
6	34901-050-621	BULB, headlight (6V-6W)(YELLOW)F	1	-	-	
	34901-063-690	BULB, headlight (6V-6W)(WHITE)DK	1	-	-	
7	34902-122-690	EARTH, headlight	1	-	-	
8	35100-143-600	SWITCH ASSY, lighting	1	-	-	
9	37200-099-920	SPEEDOMETER ASSY., (V.D.O.)	1	-	-	
10	37202-099-920	JOINT speedometer (V.D.O.)	1	-	-	
11	51516-093-000	STAY, headlight, right	1	-	-	
12	51517-093-000	STAY, headlight, left	1	-	-	
13	90548-099-003	WASHER, plain, 10 mm.	1	-	-	
14	90310-099-003	NUT, thin, speedometer	1	-	-	
15	94101-06000	WASHER, plain 6 mm.	2	-	-	
16	92000-06022	BOLT, hex, 6 X 22	2	-	-	
°17	61301-143-600XL	CASE, headlight (Ivory White)	1	-	-	

° Not available separately.

# COLOUR CHART PF 50

COLOUR	COLOUR CODE	PF 50 STANDARD «AMIGO»							PF 50 REAR CUSHION «AMIGO-R»					PF 50 NOVIO-REAR CUSHION «NOVIO-R»						
		BELGIUM	NETHERLAND	FRANCE	GREAT-BRIT.	ITALY	DENMARK	EXPORT	BELGIUM	NETHERLAND	FRANCE	FRANCE-RDX	GREAT-BRIT.	DENMARK	PORTUGAL	BELGIUM	NETHERLAND	GREAT-BRIT.	FRANCE	
SCARLET RED	C	•	•	•	•	•	•	•					•	•	•			•		
MEDIO BLUE	ME	•			•			•	•	•	•	•	•	•	•	•	•	•	•	
ORIENTAL YELLOW	OY	•			•			•	•	•	•	•	•	•	•	•	•	•	•	
BLACK	B		•																	
ENGLISH GREEN	EG	•	•	•		•	•	•	•					•						
IVORY WHITE	XL			•																
PASTEL BLUE	PB								•	•	•			•	•	•		•		
IRIS GREEN	IG			•																
CANNES BLUE	BC									•							•			
NATIONA ORANGE	NO									•							•			
ITALIAN YELLOW	IY									•								•		

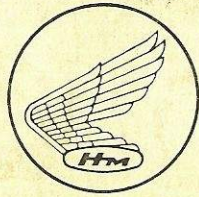

**HONDA MOTOR**

DD-5-7-75

# IceniCAM On-Line Library

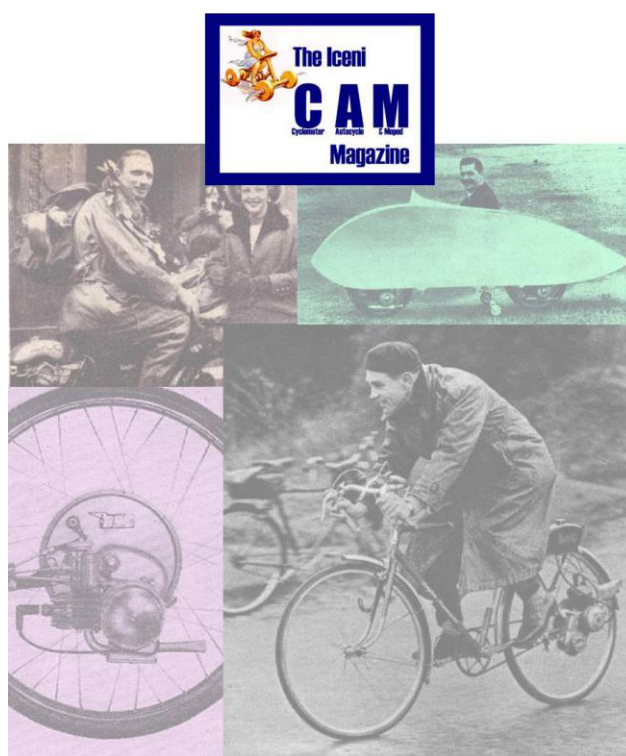

[www.icenicam.org.uk](http://www.icenicam.org.uk)