

IceniCAM On-Line Library

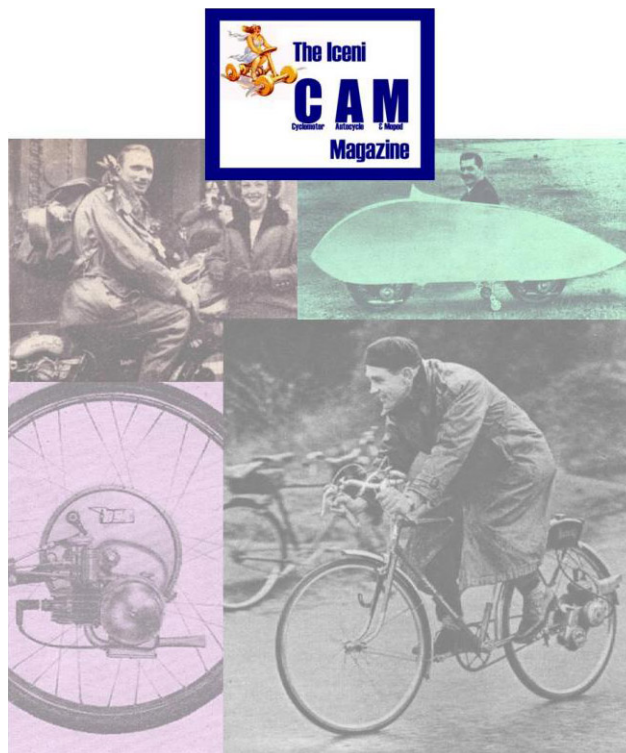

www.icenicam.org.uk

WORKSHOP MANUAL

moped

model 210

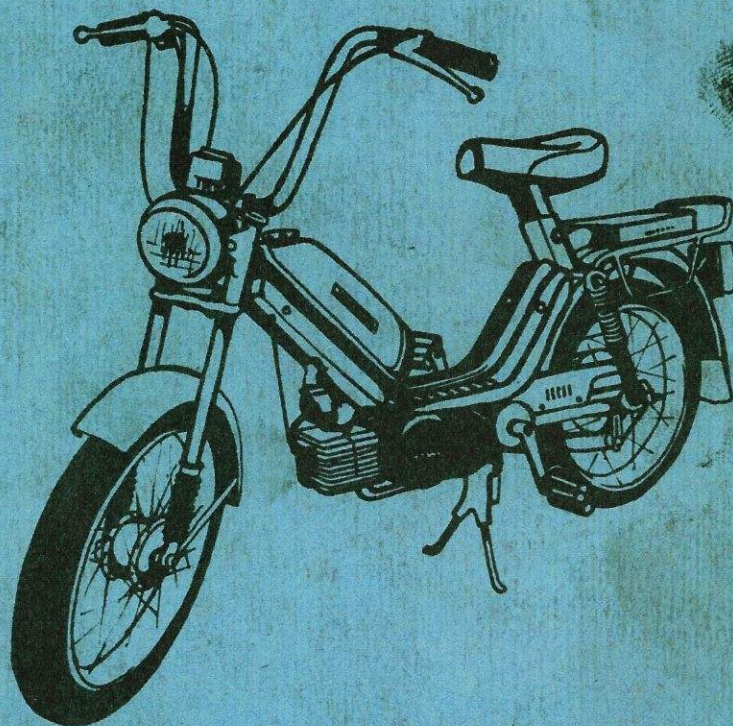

**ZVL - POVAŽSKÉ STROJÁRNE,
koncernový podnik
POVAŽSKÁ BYSTRICA**

CONTENTS

This workshop manual is intended primarily for all repair shops and their workers concerned with repairs of our model 210 moped. It does not contain servicing jobs and repairs described in the Rider's Manual but only repairs for which special assembly tools and jigs are required. The purpose of this manual is to facilitate the work of the repairmen and to improve servicing of our products. Any changes and deviations from standard procedures will be announced in our Service Bulletins.

**ZVL concern
Považské strojárne
Klementa Gottwalda works
sales and technical service
department**

CONTENTS

I. Moped specifications

II. General technical data

1. Assembly tools and jigs
2. Moped lubrication — Lubrication Chart
3. List of bearings, sealing rings and bushes
4. Engine torque transmission — diagram and description

III. Engine

1. Removing engine from frame
2. Removing cylinder head, cylinder and piston
3. Grading of cylinders and pistons
4. Clutch dismantling
5. Carburettor
6. Crankshaft

IV. Frame

1. Front telescopic fork
2. Front and rear wheel
3. Rear wheel telescopic suspension

V. Electrical equipment

1. Alternator
2. Ignition system
3. Wiring diagram
4. Diagnosing electronic ignition defects

VI. Causes of defects and their removal

1. MOPED SPECIFICATIONS

Engine type	air cooled, two-stroke single-cylinder unit
Swept volume	49 c.c.
Cylinder bore × piston stroke	39 × 41 mm
Engine power output	1.75 kW at 5,000 r.p.m. ± 8 %
Clutches	automatic, dry, centrifugal
Gearbox	two-speed unit
Engine to rear wheel transmission ratio	1st-speed overall ratio — 1 : 24.4231 2nd-speed overall ratio — 1 : 13.7305
Primary transmission	indented belt
Secondary transmission	link chain
Pedal drive transmission ratio	1 : 0.692
Pedal-actuated starting gear	overall ratio 1 : 0.0504
Front suspension	telescopic fork without shock absorbers — 60 mm stroke
Rear suspension	telescopic suspension units without shock absorber — 60 mm stroke
Brakes	internal expanding shoe — brakes controlled by levers on handlebars
Brake dimensions	85 × 20 mm
Tyres	2 1/4 × 16"
Inflation pressures — front tyre	196 kPa (2 atm.)
— rear tyre	245 kPa (2.5 atm.)
Moped dry weight	51 kg
Moped running weight	54 kg
Road speed — sustained	35 km/hr.
— maximum	40 km/hr. ± 5 %
Fuel tank filling capacity	4 litres
Fuel reserve	0,7 litres
Maximum climbable gradient with rider weighing 75 kg	25 %
Noise	70 decibels
Ignition system	6-volt, contactless with semiconductor elements
Spark plug	PAL N 7 R
Headlamp	6 V/21 W
Tail lamp	6 V/5 W
Speedometer lighting	6 V/2 W
Fuel consumption	1.8 litres/100 km at 27 km/hr.
Load capacity, maximum	90 kg including 5 kg luggage on carrier

Note:

When exceeding the load capacity, it is necessary to decrease the maximum speed proportionally.

**Tightening Torques of Screws, Bolts and Nuts
Engine.**

Tightened part	Thread dimension mm	Tightening torque Nm
Engine (crankcase) covers	6	8
Cylinder head	6	7
Starting clutch	10	25
2nd-speed clutch drum	10	20
Frame		
Steering head nut	12	50
Handlebars	6	
Front wheel spindle	12	50
Rear wheel spindle	12	50
Engine fastening screws	8	30
Saddle	8	30
Pedals	14	65
Pedal crank	6	10
Rosette	6	19

LOCATION OF MOPED SERIAL No.

- a) on steering head
- b) on right-hand bottom side of engine

IGNITION ADVANCE

1 to 1.5 mm before piston top dead centre (TDC)

FUEL — OIL/PETROL MIXING RATIO

- 1:25 during running-in period
- 1:33 after running-in period

**WHEN ORDERING SPARE PARTS, INDICATE
THE YEAR OF MANUFACTURE AND ENGINE
No.**

II. GENERAL TECHNICAL DATA

1. Assembly tools and jigs (Fig. 1)

Ord. No.	Proprietary No.	Name	Use
1	3T 210-10 000-14.5	Crankcase halves separator	Engine dismantling
2	928-1000-1.5	Clutch drum retaining jig	Clutch drum loosening
3	50-1200-1.1	Gudgeon pin drift	Gudgeon pin removal and reinstallation
4	4T 210-2100	Starting clutch compressor	Starting clutch removal and reinstallation
5	4T 210-2200-01	Clutch drum drag	Clutch drum removal
6	975-1400-1.1	Ignition advance gauge	Advance adjustment
7	4T 928-1200-01.03	GUFERO sealing ring installer	Protection of GUFERO sealing ring during installation
8	928-6000-1.1	Rotor drag	Alternator rotor removal
9	MN 1100-7.1	Hook	Installation of starting clutch springs
10	4T 928-1200-01.4	Pilot pin-A	Piston removal and reinstallation
	4T 928-1200-01.5	Pilot pin-B	
11	4MT 28-1000-1 2	Piston ring compressing sleeve	For compressing piston rings on installation

Fig. 1

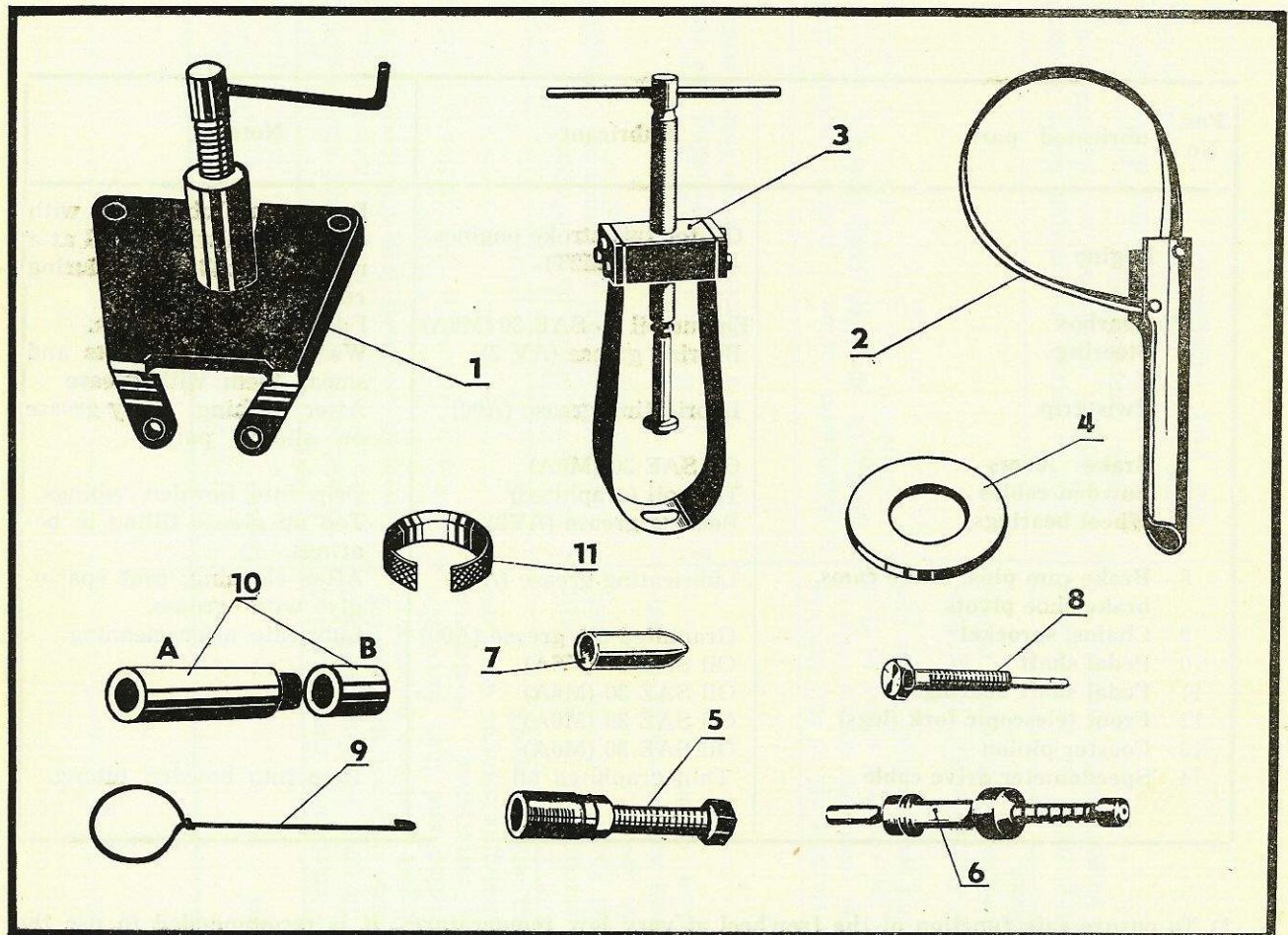

2. Moped Lubrication — Lubrication Chart (Fig. 2)

Fig. 2

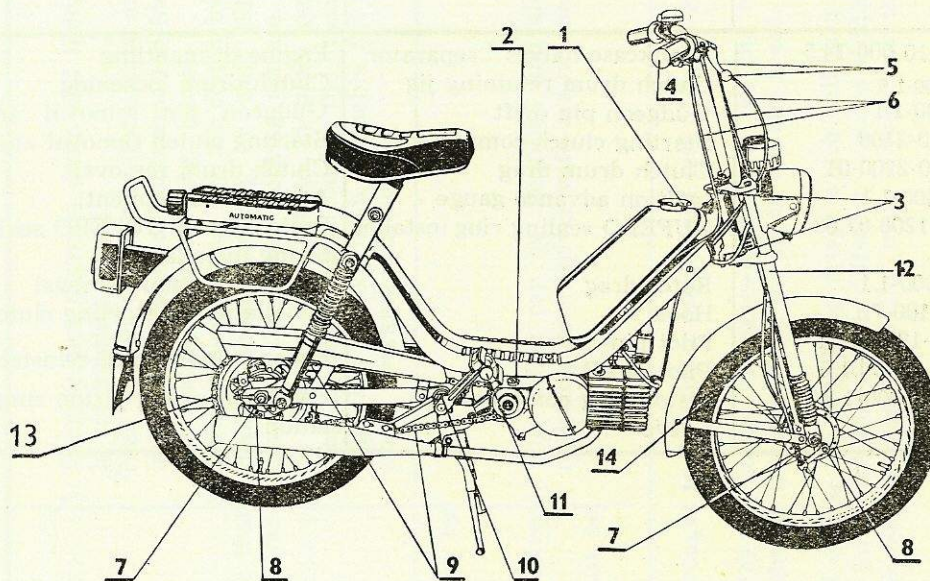

Pos. No.	Lubricated part	Lubricant	Note
1	Engine	Oil for two-stroke engines — SAE 30 (M2T)	Permanent lubrication with oil admixed with petrol at a ratio of 1:33 (1:25 during running in).
2*	Gearbox	Engine oil — SAE 30 (M6A)	Filling — 0.08 litres.
3	Steering	Bearing grease (AV 2)	Wash dismantled parts and smear them with grease
4	Twistgrip	Lubricating grease (A00)	After washing, apply grease on sliding parts.
5	Brake levers	Oil SAE 30 (M6A)	Drip into bowden tubings.
6	Bowden cables	Thin oil (graphited)	
7	Wheel bearings	Bearing grease (AV2)	Top up grease filling in bearings.
8	Brake cam pins, brake cams, brake-shoe pivots	Lubricating grease (A00)	After cleaning, coat sparingly with grease.
9	Chains, sprocket	Lubricating grease (A00)	Lubricate after cleaning.
10	Pedal shaft	Graphited oil, grease (A00)	
11	Pedal shaft bearings	Oil SAE 30 (M6A)	
12	Front telescopic fork (legs)	Oil SAE 30 (M6A)	
13	Coaster pinion	Oil SAE 30 (M6A)	
14	Speedometer drive cable	Thin graphited oil	Drip into bowden tubing.

*) To ensure safe function of the freewheel at very low temperatures, it is recommended to use the M3A oil (thinner).

Fig. 3

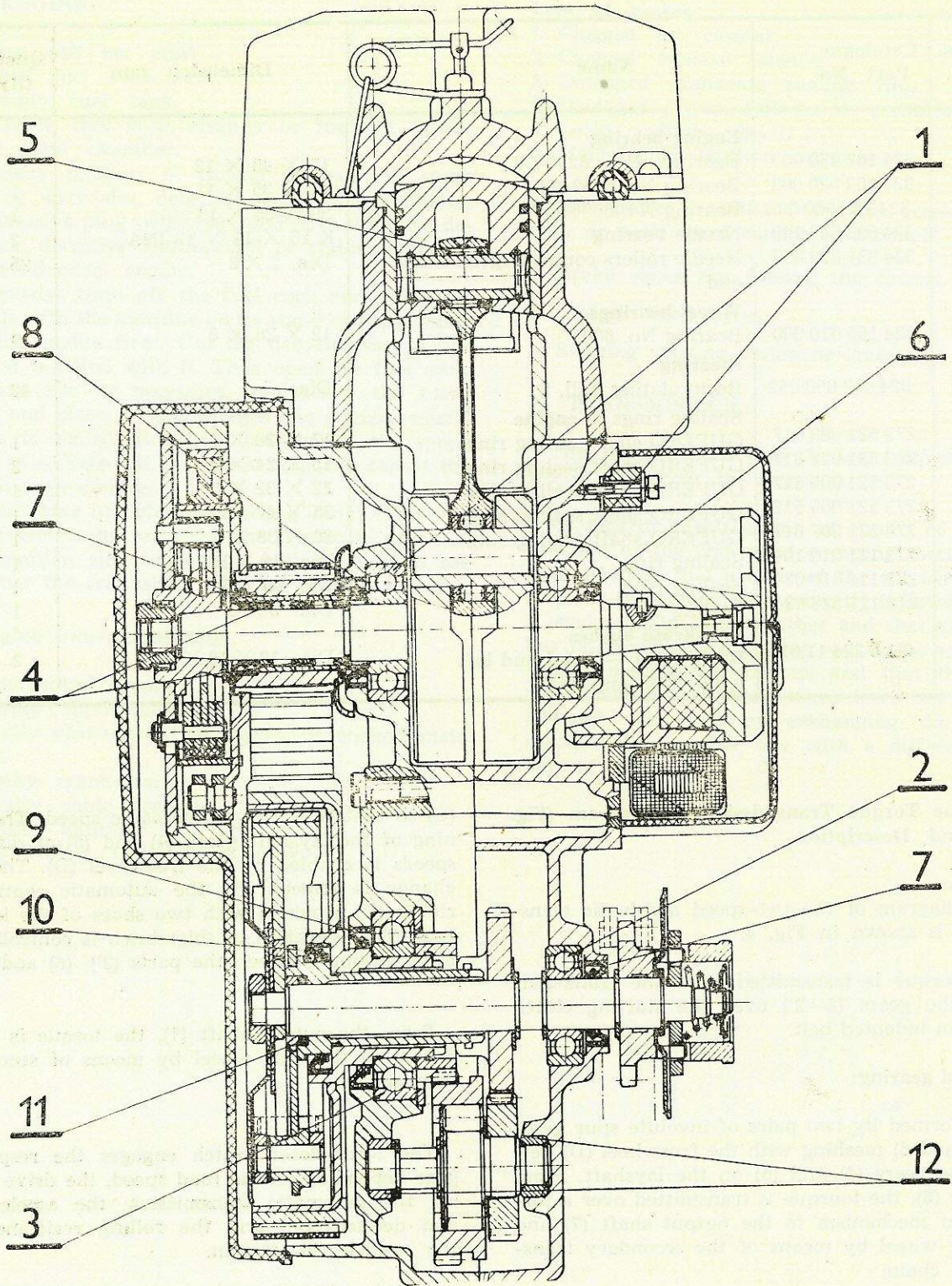

3. List of Bearings, Sealing Rings, and Bushes (Fig. 3)

Pos. No.	Catalogue Part No.	Name	Dimension mm	Quantity
		Engine bearing		
1	324 162 030 003	Bearing No. 6203/C3	17 × 40 × 12	2
2	324 162 020 003	Bearing No. 6202/C3	15 × 35 × 11	1
3	324 165 060 003	Bearing No. 6006/C3	30 × 55 × 13	1
4	324 592 523 149	Needle bearing	K 15 × 19 × 13 INA	2
5	324 931 020 053	Needle rollers-connectingrod small end	Dia. 2 × 8	25
		Wheel bearings		
	324 165 010 000	Bearing No. 6001	12 × 28 × 8	4
		Steering		
	324 912 050 052	Recirculating ball, 5	Dia. 5	42
		Sealing rings in engine		
6	273 521 003 517	GUFERO shaft sealing ring	17 × 28 × 7	1
7	273 521 002 617	GUFERO shaft sealing ring	15 × 24 × 7	2
8	273 521 005 317	GUFERO shaft sealing ring	22 × 32 × 7	1
9	273 521 009 517	GUFERO shaft sealing ring	35 × 47 × 7	1
10	273 521 007 617	GUFERO shaft sealing ring	28 × 38 × 7	1
11	273 111 010 104	Sealing ring	Dia. 19 × 15	1
	273 111 010 024	Sealing ring	Dia. 9 × 5	1
	273 111 526 025	Sealing ring	Dia 8 × 2	1
		Crankcase bushes		
12	451 9 224 11 018	Bush, right — hand and left hand crankcase half	Dia 12 × 18 × 8	2

4. Engine Torque Transmission — Diagram (Fig. 4) and Description

Gearbox

The diagram of the two-speed automatic transmission is shown in Fig. 4.

The torque is transmitted from the crankshaft (1) to the gears (2—2') over the starting clutch (B) by an indented belt.

1st-speed gearing:

It is formed by two pairs of involute spur gears (3, 4, 5 and 6) meshing with the freewheel (D) between the gears (4) and (5) on the layshaft. From the gear (6), the torque is transmitted over a force closed mechanism to the output shaft (7) and the rear wheel by means of the secondary transmission chain.

2nd-speed gearing:

Parts (3), (6), and (7) are coupled with the clutch

(C) so that they run at the same speed. The running of the layshaft gears (4) and (5) at different speeds is enabled by the freewheel (D). The gear change is effected by the automatic centrifugal clutch (C) provided with two shoes of the leading type. The operation of this clutch is controlled by force closing between the parts (2'), (6) and (7).

From the output shaft (7), the torque is transmitted to the rear wheel by means of secondary transmission.

The force-closed clutch engages the respective gear depending on the road speed, the drive taken off the automatic transmission, the acceleration and deceleration, and the rolling resistances of the vehicle in terrain.

The output shaft (7) with the gear-change mechanism runs in two ball bearings. The layshaft is supported by two bronze bushes.

Fig. 4.

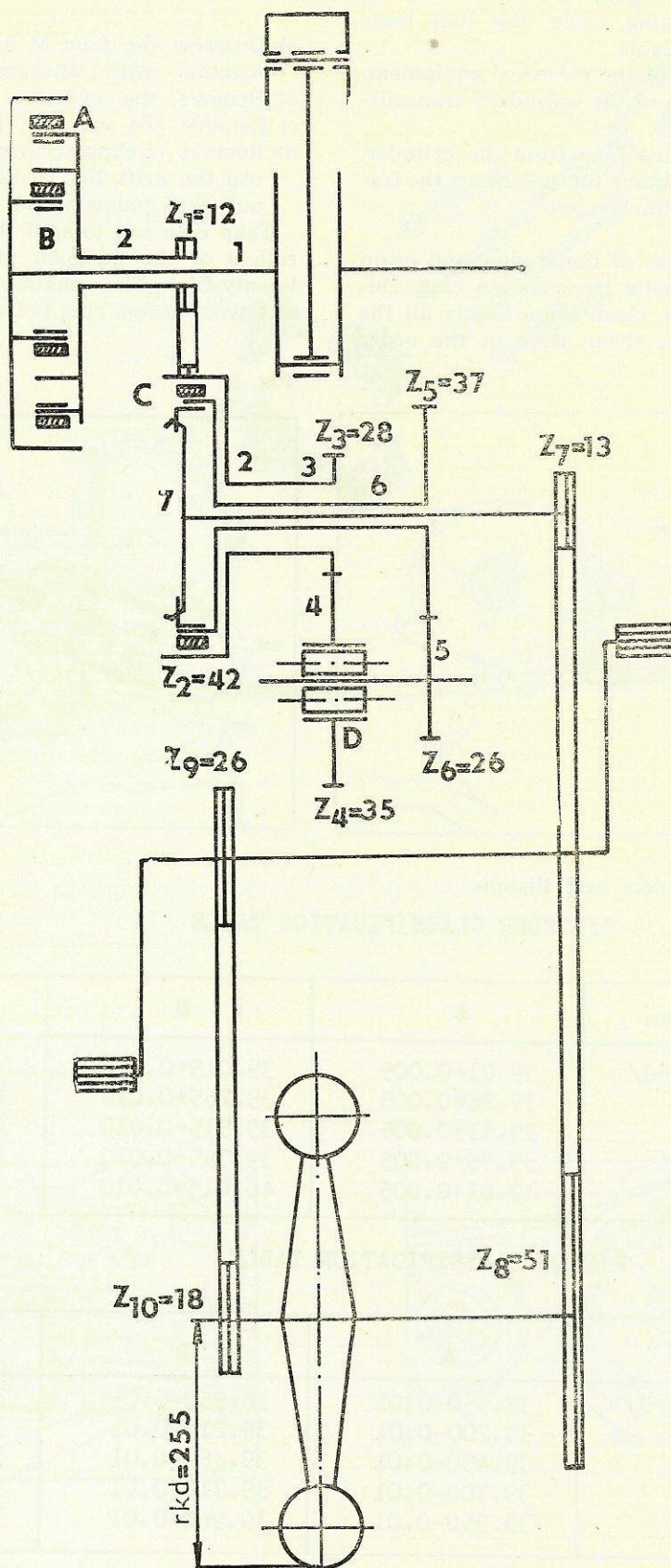

III. ENGINE

1. Removing engine from frame

- Remove the engine guards.
- Detach the spark plug cable, the fuel hose, and the throttle cable.
- Disconnect the leads of the electrical equipment.
- Disconnect the chain of the secondary transmission.
- Disconnect the exhaust pipe from the cylinder.
- Remove screws fastening the engine to the frame, and lift off the engine.

Clean well the surfaces of the engine, and drain the oil from the automatic transmission case. During engine dismantling, clean immediately all the removed parts and put them aside in the order

Fig. 5

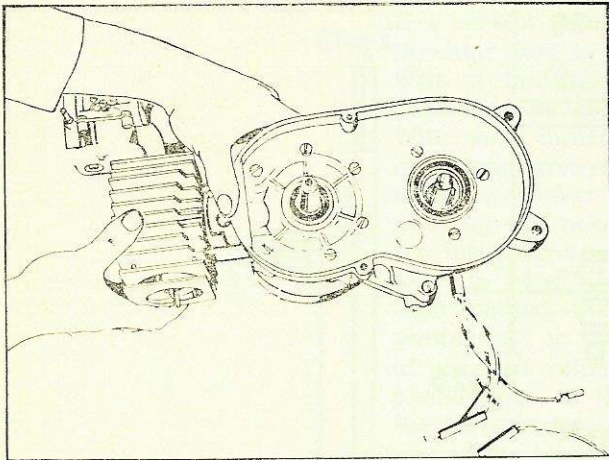

of their removal so that they can be reassembled correctly and in the shortest possible time.

2. Removing Cylinder Head, Cylinder and Piston

- Unscrew the four M 6 nuts and lift them off together with washers from the studs.
- Remove the cylinder head.
- Remove the cylinder (Fig. 5).
- Remove circlips securing the gudgeon pin and use the drift No. 50-12000-1.1 (Fig. 6) to drive out the gudgeon pin.

Take care not to spill the dia. 2×8 mm needle rollers of the gudgeon pin (there are altogether twenty-five). The maximum permissible ring gap of a worn piston ring is from 0.6 to 0.8 mm.

Fig. 6

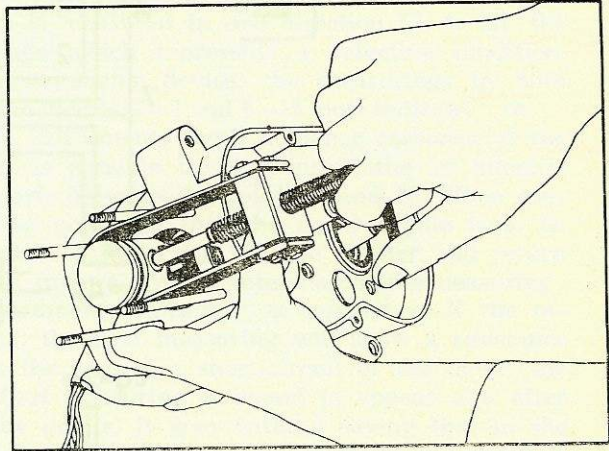

3. Grading of Cylinders and Pistons

CYLINDER CLASSIFICATION TABLE

Cylinder class	A	B	C
Normal /standard/	39.01+0.005	39.015+0.010	39.025+0.010
1 st rebore	39.26+0.005	39.265+0.010	39.275+0.010
2 nd rebore	39.51+0.005	39.515+0.010	39.525+0.010
3 rd rebore	39.76+0.005	39.765+0.010	39.775+0.010
4 th rebore	40.01+0.005	40.015+0.010	40.025+0.010

PISTON CLASSIFICATION TABLE

Piston class	A	B	C
Normal /standard/	38.950-0.01	38.960-0.01	38.970-0.01
1 st rebore	39.200-0.01	39.210-0.01	39.220-0.01
2 nd rebore	39.450-0.01	39.460-0.01	39.470-0.01
3 rd rebore	39.700-0.01	39.710-0.01	39.720-0.01
4 th rebore	39.950-0.01	39.960-0.01	39.970-0.01

Check the dimension for grading the pistons in the individual classes 34.5 mm from the piston base (Fig. 7).

Fig. 7

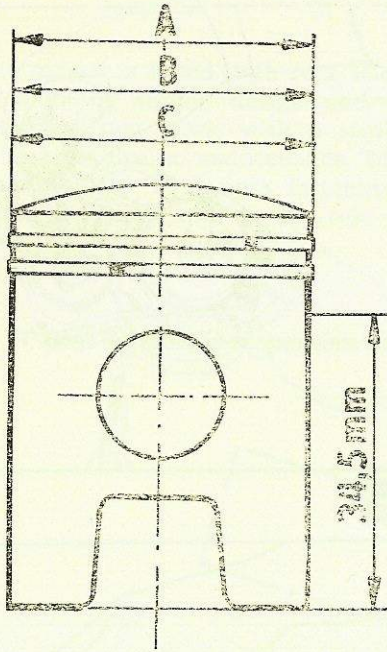

4. Clutch Dismantling

After removing two M 5×30 screws, lift off the left-hand clutch cover.

Using the clutch drum retaining jig No. 928-1000-1.5 retain the starting clutch drum and loosen the nut with the spanner No. 17 (Fig. 8). Pull off the clutch drum using the drag No. 4T 210-2200-01 (Fig. 9). With a screwdriver remove three circlips

Fig. 8

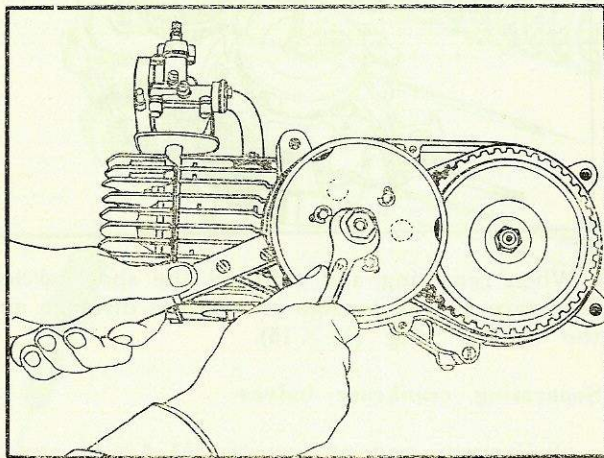
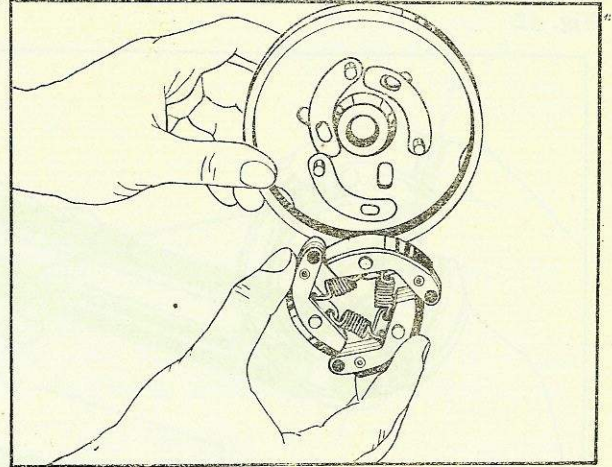

Fig. 10



from the recesses to loosen the clutch starting shoes (Fig. 10).

For reassembly use the washer No. 4T 210-2100 and clutch drum drag No. 4T 210-2200-01 and secure the clutch with the circlips (Fig. 11).

Fig. 9

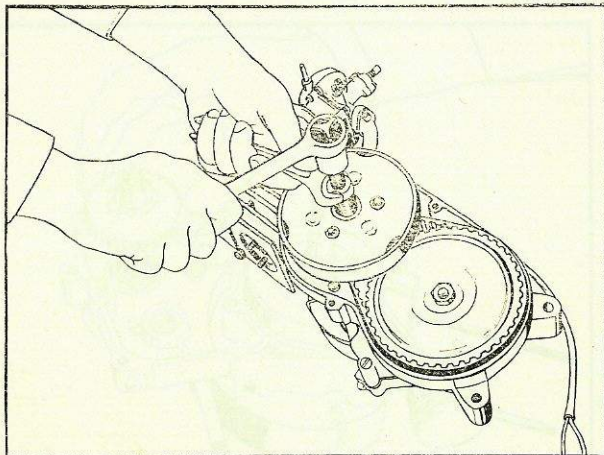
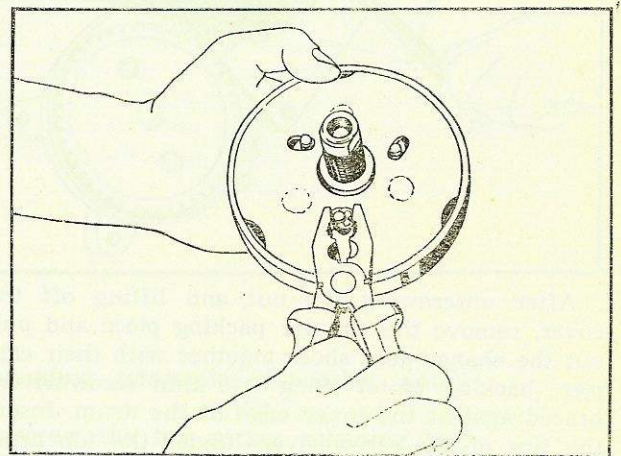

Fig. 11



After having removed the drum with starting shoes, rotate and gently pull the starting drum with the small pulley to remove it together with the indented belt.

Work carefully so as not to damage the needle bearings and washers.

For the removal and refitting of the starting shoes use the jig (hook) No. MN 1100-7.1 (Fig. 12) or flat pliers.

Loosen the nut of the drum housing the change-gear shoes with the spanner No. 17 while holding the output shaft with the spanner No. 10 on the side of the drive (power take-off) gear to prevent its rotation. It is recommended to put the engine on the work bench with the ignition side down to prevent the oil from getting into the 2nd-speed clutch drum.

Fig. 12

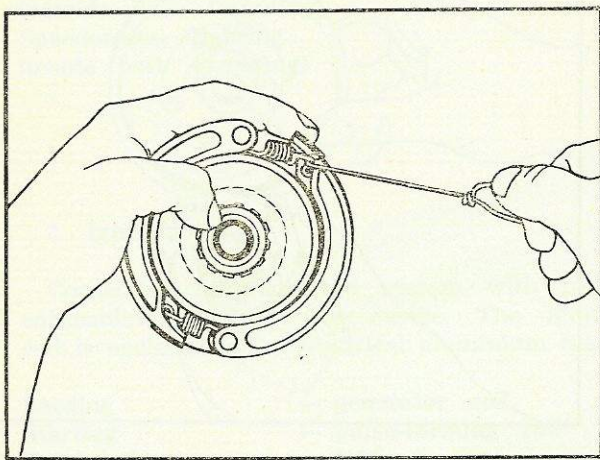
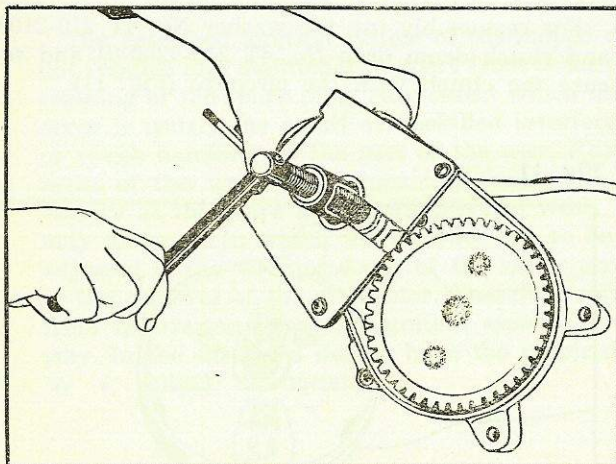

Fig. 13



After unscrewing the nut and lifting off the cover, remove the circular packing piece and pull out the change-gear shoes together with their carrier (backing plate) using two thin screwdrivers braced against the inner edge of the drum. Insert the tips of the screwdrivers under the top arms of the shoe near the pivots and opposite each other. By carefully pushing the screwdriver handles downward you will lift the carrier with the shoes out of the drum.

Wipe the oil off the parts immediately and put the parts in a clean place. If the drum or the shoe linings are stained with oil, they have to be degreased thoroughly. Finally remove the drum of the change-gear clutch.

Fig. 14

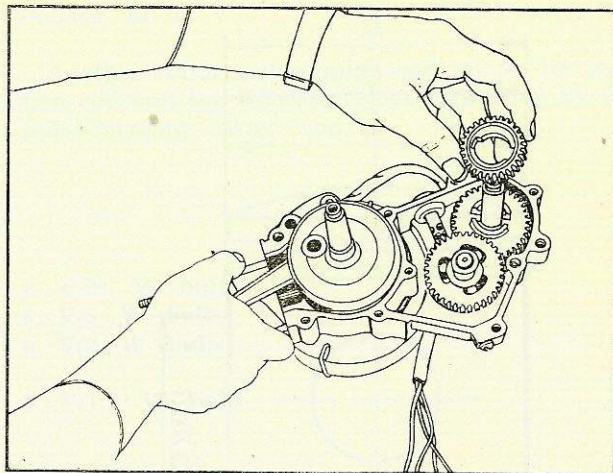
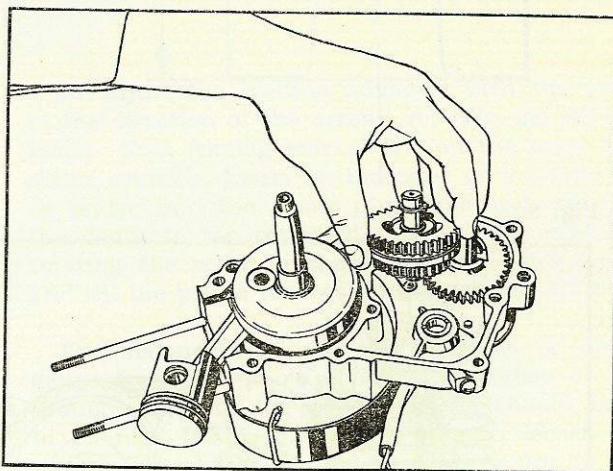

Fig. 15



When removing and refitting the shoe carrier, take care not to damage or lose the distance and the sealing ring (19 × 15).

Separating crankcase halves

- Unscrew and remove ten M 6 × 45 screws from the left-hand crankcase half.
- Fit the jig (crankcase halves separator) No.

Fig. 16

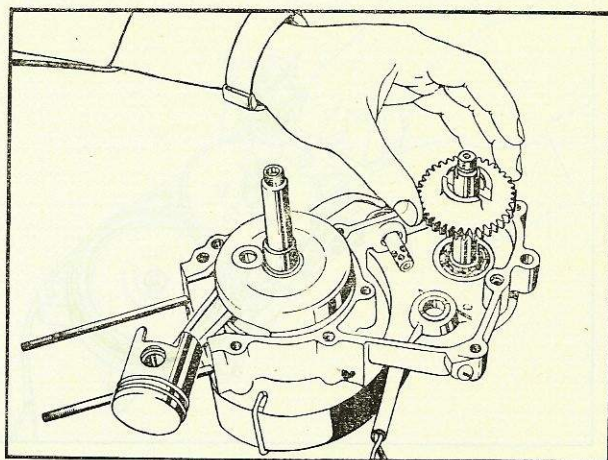

3T 210-10 000-14.5 on the studs and fasten it by two screws on the left-hand half of the crankcase.

c) Pull off the left-hand crankcase half (Fig. 13).

Removing gears

a) Removing driving gear (28 teeth) from output shaft — see Fig. 14.

b) Removing coaster pinion — see Fig. 15.

c) Removing driven gear — see Fig. 16.

Removing driver assembly

a) Using a screwdriver, loosen the circlip and pull the washer, the volute spring and the complete driver off the output shaft (Fig. 17).

b) Using circlip pliers, loosen the circlip and pull the washer, the cap, and the sprocket off the shaft (Fig. 18).

c) After loosening the circlip, press the output shaft out of the case.

When reassembling the output shaft, use the sealing ring installer (Fig. 19) to protect the shaft sealing rings from damage.

Fig. 17

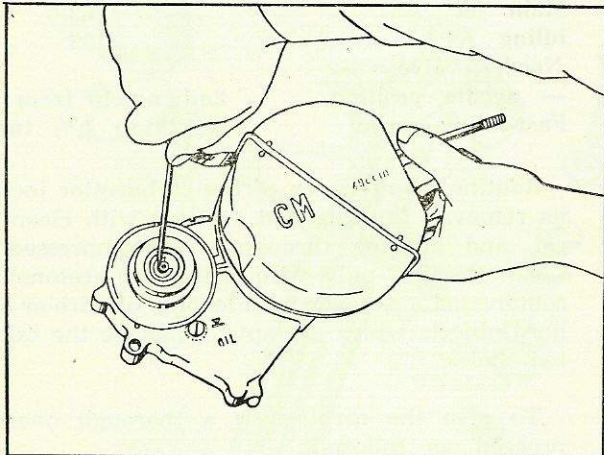

Removing alternator

a) Use a screwdriver to loosen the alternator cover retaining spring, and remove the cover. Then unscrew the M 5×25 screw holding down the rotor.

b) Using the rotor drag No. 928-6000-1.1 pull off the rotor (Fig. 20) and then loosen the lock pin.

c) Remove two M 4×22 screws fastening the stator, and pull the stator out of the crankcase right-hand half together with the leads.

After having removed the transmission clutch and the alternator, use a hand press to press the crankshaft out of the crankcase.

Engine reassembly

To reassemble the engine, reverse the procedure for its dismantling.

a) Warm up the right-hand of the crankcase up to about 70 to 80 °C and press in the crankshaft.

b) Reassemble and reinstall the transmission.

c) Press on the left-hand half of the crankcase (warmed up to about 70 to 80°C).

Fig. 18

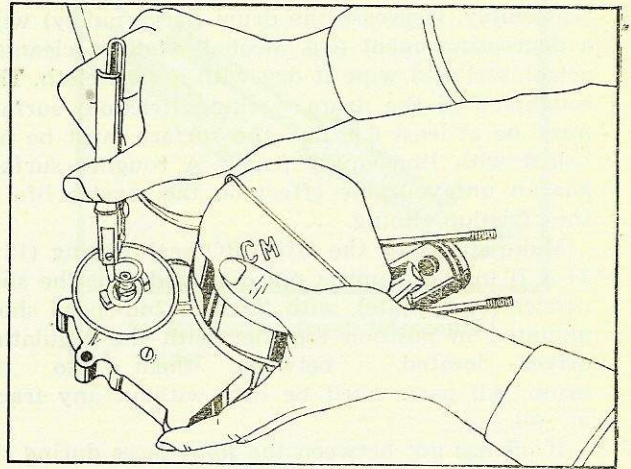

Fig. 19

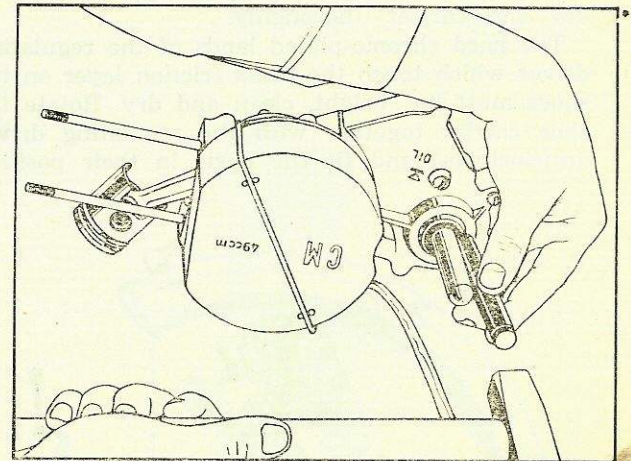
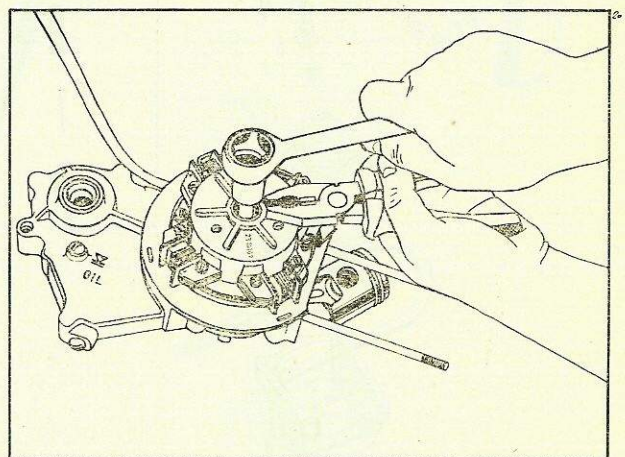

Fig. 20



d) Reassemble and reinstall the clutch.

e) Reinstall the reassembled alternator and the assembled driver (engine drive engaging and disengaging device).

f) Reinstall the piston, the cylinder, and the cylinder head.

If any of the parts are worn beyond the acceptable measure, replace them with new ones.

Reassembling 2nd-speed clutch

Observe utmost cleanliness during the clutch reassembly. Degrease the drum (large pulley) with a degreasing agent (e.g. alcohol, acetone, cleaning petrol, etc) and wipe it dry with a clean cloth. The roughness of the drum working (friction) surface must be at least 0.8, i. e. the surface must be polished with fine emery paper. A rougher surface has an unfavourable effect on the service life of the friction lining.

Make sure that the GUFERO sealing ring (15 × 24 × 7) in the drum is not damaged. Put the shoe carrier (bade plate), with the two 2nd-speed shoes mounted in position together with the regulating driver located between them into the drum. All parts must be dry, without any traces of oil.

If oil has got between the joint faces during the dismantling, remove the 2nd-speed shoes and dip the carrier in a solvent (degreasing agent). Then dry the carrier thoroughly.

The hard chrome-plated lands of the regulating driver which touch the brass friction layer on the shoes must be bright, clean and dry. Rotate the shoe carrier together with the regulating driver anticlockwise and fit the parts in their position

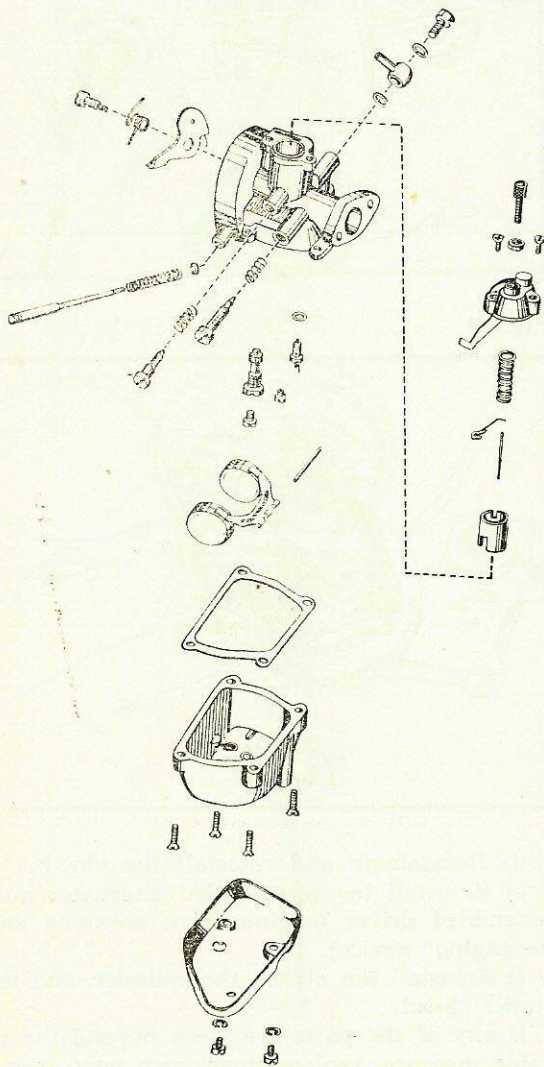

Fig. 21

by a slight pressure of the hand. Never touch the friction lining and the friction surface of the drum with greasy hands. Place the „O“ sealing ring on the recess (clean and undamaged) of the carrier hub and locate the metal bush on the „O“ ring. Then apply a tube of sufficient length and the same diameter as the bush on the bush, and by rotating and pressing down the tube, press the bush through the „O“ ring inside the hub. Then install the inside driver which ensures that the regulating driver controls both shoes at the same time. For this reason, the holes must be perfectly clean and the parts must have a certain clearance along the circumference with the exception of the contact areas.

Locate the circular sheet-metal washer and the clutch cover, and then screw down and tighten well the M 10 × 1.25 nut.

5. Carburettor (Fig. 21)

The moped is fitted with the JIKOV 2912 DC carburettor with the following parts and adjustments:

Main jet	63
Idling jet	35
Needle valve	
— needle position	2nd notch from top
Fast-idling screw	540° (1 to 1 1/2 turns)

Routine maintenance of the carburettor includes its removal, flushing and swilling with clean petrol, and blowing through with compressed air. Clean the jets only with petrol (or acetone) and compressed air, never with lengths of wire or other hard objects which are apt to damage the calibrated holes.

To give the carburettor a thorough overhaul, proceed as follows:

1. Remove the carburettor from the engine, take it apart, and clean its parts thoroughly.
2. Discard worn parts and replace them with new ones.
3. Check the flatness of the flange and true it up if necessary on an abrasive cloth stretched on a flat board.
4. After trueing up the flange clean the carburettor body thoroughly once again.
5. Check the jets and adjustments for compliance with the recommended values.
6. Adjust the needle and the fast-idling screw as recommended and reassemble the carburettor.
7. Refit the carburettor on the engine. Start the engine, warm it up, and adjust the richness of the mixture by means of the air-correction screw. Then adjust the idling speed (from 1,600 to 1,800 r.p.m.) by means of the stop screw, and the needle valve and the free movement of the twistgrip by means of the throttle cable guide.

Checking and adjusting fuel level in float chamber

Check and adjust the fuel level after every renewal of the fuel float or if the fuel leaks from the carburettor and the leakage is not due to a defective float or needle. Fuel level adjusting procedure:

1. Rough (mechanical) adjustment — see Fig. 22

With the carburettor removed from the engine, remove the float chamber cover. Turn the carburettor so that the floats are directed upwards. Check that the floats move freely on the spindle and that they are perpendicular to the carburettor centre line. Check also their height which must reach the level of the venturi tube top edge. If this is not the case, adjust the height of both floats by bending the spindle. Floats adjusted in this way should maintain the fuel in the float chamber at the correct level.

Fig. 22

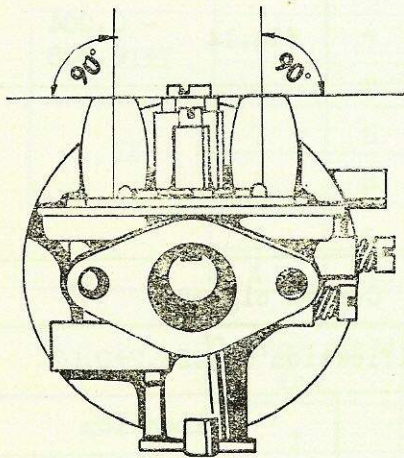

2. Checking fuel level using the jig illustrated in Fig. 22a

After having adjusted, the fuel level mechanically it is recommended to check the adjustment with the help of the jig which you can make of plexiglass (Perspex) according to the drawing. Screw the jig on to the float chamber (bottom drain screw) and admit fuel into the carburettor. Its level should reach the centre index line with a tolerance of ± 1 mm. If this is not the case, adjust the floats by bending the spindle upward or downward as necessary. The fuel level adjusted in this way complies with the manufacturer's requirements. When checking the fuel level in the carburettor removed from the engine, it is necessary to observe the same height of the pressure column as exists between the fuel tank and the carburettor fitted on the engine.

Fig. 22a

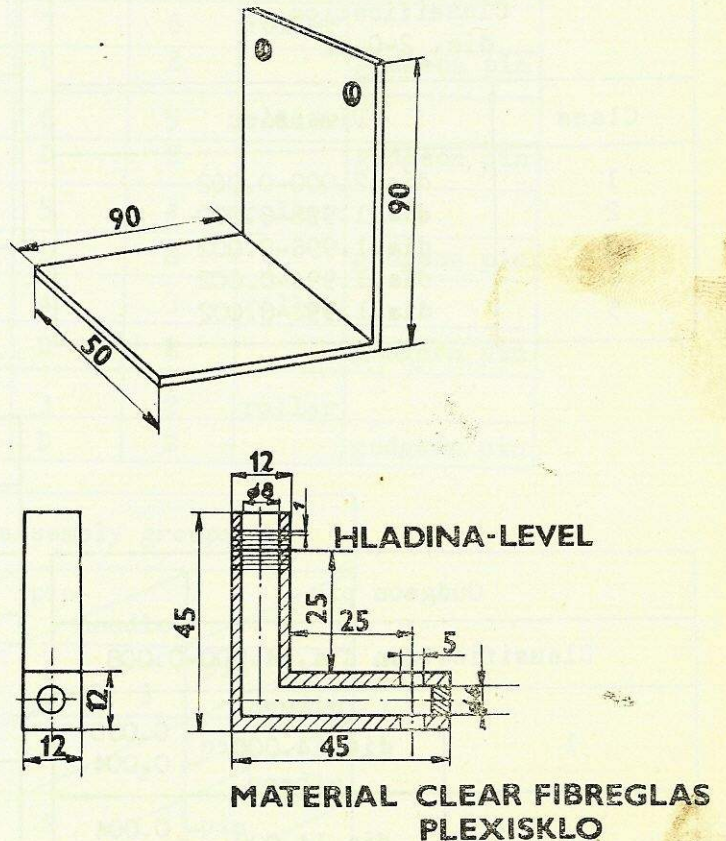

Classification Tables

Conrod small end	
Classification dia.17.984+0.016	
Class	Dimension
I	dia.17.984+0.004
II	dia.17.988+0.004
III	dia.17.992+0.004
IV	dia.17.996+0.004

Conrod small end	
Classification dia.18.003+0.010	
Class	Dimension
I	dia.18.003+0.003
II	dia.18.006+0.003
III	dia.18.009+0.003

Small end needles /rollers/	
Classification dia. 2-0.01	
Class	Dimension
1	dia.2.000-0.002
2	dia.1.998-0.002
3	dia.1.996-0.002
4	dia.1.994-0.002
5	dia.1.992-0.002

Piston - gudgeon pin hole	
Classification dia.14 - 0.004 - 0.012	
Class	Dimension
X	dia.14 - 0.008 - 0.012
Y	dia.14 - 0.004 - 0.008

Gudgeon pin	
Classification dia.14.000-0.008	
Class	Dimension
1	dia.14.000 - 0.000 - 0.004
2	dia.14.000 - 0.004 - 0.008

Conrod big end	
Classification dia.26.2+0.02	
Class	Dimension
I	dia. 26.200+0.002
II	dia. 26.202+0.002
III	dia. 26.204+0.002
IV	dia. 26.206+0.002
VI	dia. 26.210+0.002
VII	dia. 26.212+0.002
VIII	dia. 26.214+0.002
IX	dia. 26.216+0.002

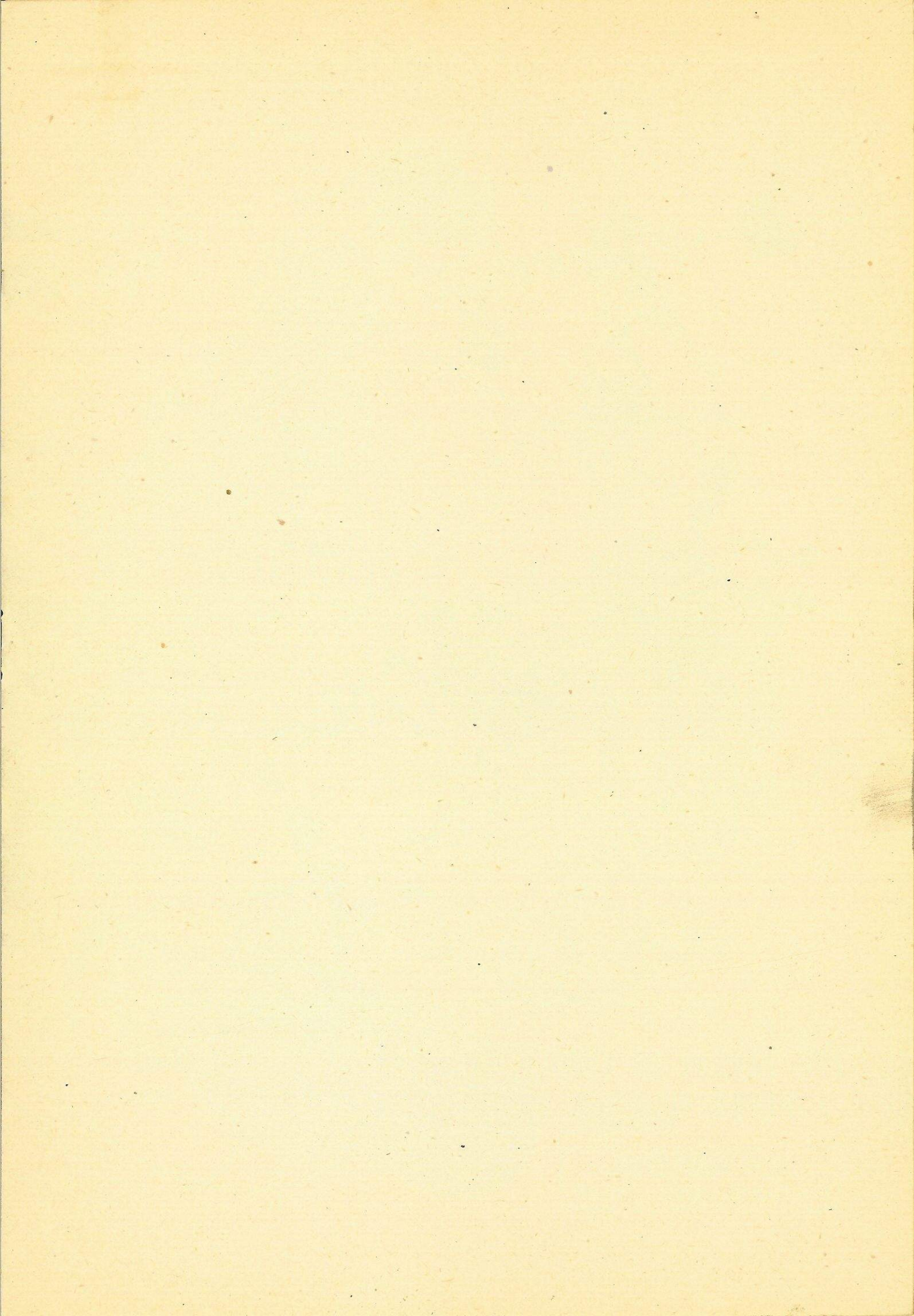

automatic 2 speed F

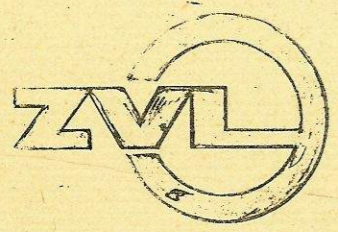
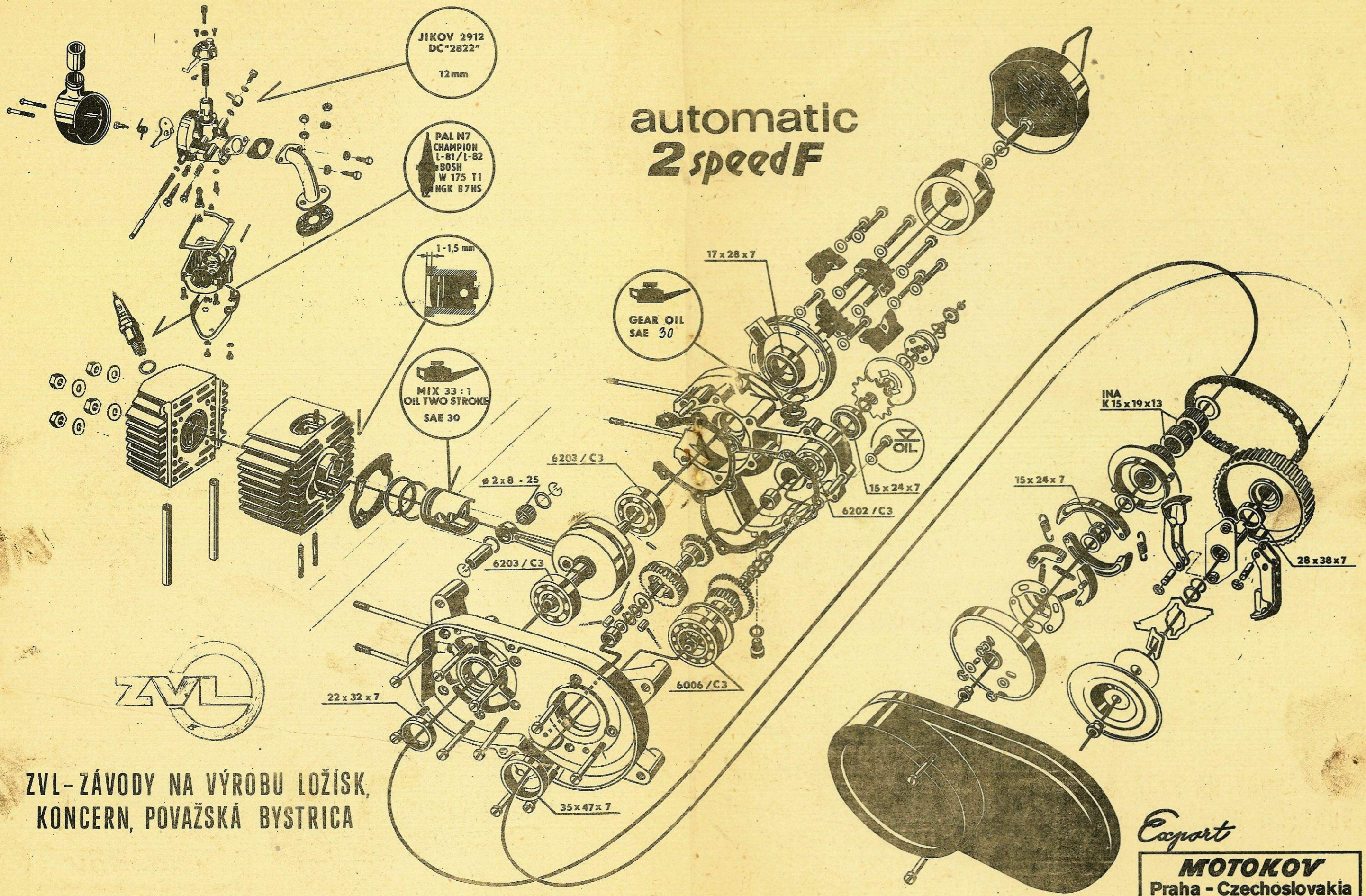

ZVL - ZÁVODY NA VÝROBU LOŽÍSK,
KONCERN, POVAŽSKÁ BYSTRICA

Expert
MOTOKOV
Praha - Czechoslovakia

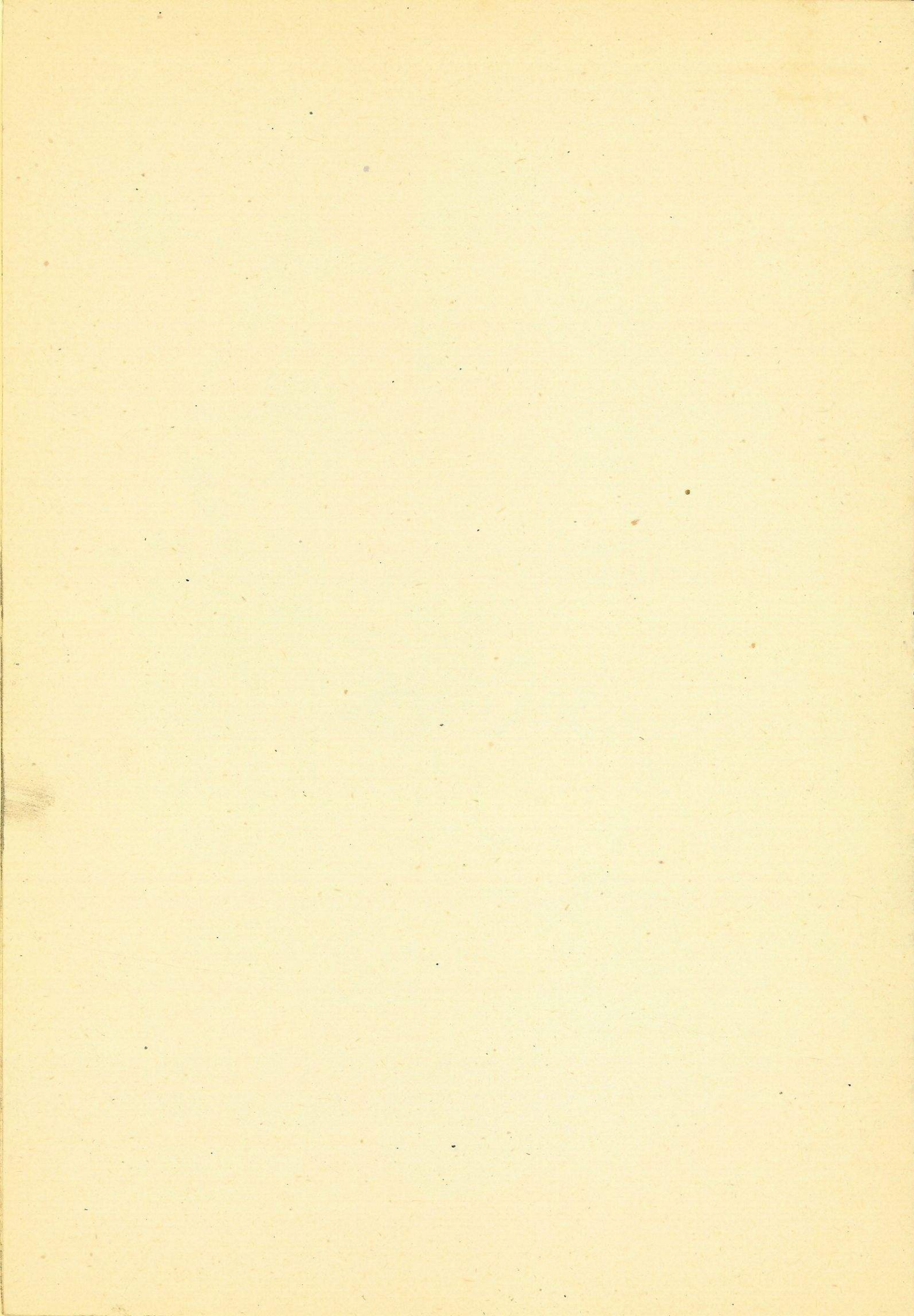

**6. Crankshaft
Removal and reinstallation**

1. Use a press with a pressure of about 50,000 N. Before removing the crankshaft, mark the relative positions of the crankshaft flywheels with index lines using a set square.

2. Press the crankpin out of one half of the crankshaft and then out of the other half.

3. Assemble the connecting rod, the crankpin and the cage with needle rollers according to the classification table.

4. Clean thoroughly all parts of the crankshaft, especially the crankpins, which must be perfectly dry.

5. Press the crankpin in the flywheel till its face is flush with the outer surface of the flywheel.

6. Fit in position the cage with needle rollers and lubricate the needle rollers with lubricating grease.

7. Press the flywheels together — observe the previously made index lines.

8. After reassembly, it is necessary to centre the crankshaft.

Connecting rod	Assembly groups					
I	15	14	13	12	11	roller
	A	B	C	D	E	gudgeon pin
II	14	13	12	11	10	roller
	A	B	C	D	E	gudgeon pin
III	13	12	11	10	9	roller
	A	B	C	D	E	gudgeon pin
IV	12	11	10	9	8	roller
	A	B	C	D	E	gudgeon pin
V	11;12	10;11	9;10	8;9	7;8	roller
	A	B	C	D	E	gudgeon pin
VI	10	9	8	7	6	roller
	A	B	C	D	E	gudgeon pin
VII	9	8	7	6	5	roller
	A	B	C	D	E	gudgeon pin
VIII	8	7	6	5	4	roller
	A	B	C	D	E	gudgeon pin
IX	7	6	5	4	3	roller
	A	B	C	D	E	gudgeon pin
X	6	5	4	3	2	roller
	A	B	C	D	E	gudgeon pin

Conrod small end	Piston assembly groups		
I	1 5	pin needle	
II	1 4	2 3	pin needle
III	1 3	2 2	pin needle
IV	1 2	2 1	pin needle
	Y	X	piston

Roller - conrod big end		
Classification - dia.4		
Designation	Diameter classification group	Class tolerance limits
1	+ 10	± 0,5
2	+ 9	
3	+ 8	
4	+ 7	
5	+ 6	
6	+ 5	
7	+ 4	
8	+ 3	
9	+ 2	
10	+ 1	
11	0	
12	- 1	
13	- 2	
14	- 3	
15	- 4	

Crankshaft aligning

Check the aligning and the permissible untrue run using a special jig with centres and two dial indicators. The crankshaft must be supported in the centres so that it can rotate. The maximum permissible relative run-out of the functional points is 0.016 mm. The functional points in this instance are the shoulders and the manufacturing process guarantee this value. Check the run-out or untrue run before installing the crankshaft in the engine. Misalignment of the crankshaft is usually caused by a crash, rough handling during transport, dropping the crankshaft on the ground or by an unskilled repair. You will obtain the correct axial (lateral) clearance of the crankshaft in the crankcase if you maintain the dimension 38—0.2 mm (distance of the shoulders for the bearings) when pressing the crankshaft together. The minimum distance of the flywheels in place on the crankpin must be 12.2 mm!

Crankshaft aligning and straightening procedure

Check the alignment of crankpins as illustrated in Fig. 23. If the crankshaft halves are mutually set off, remove the crankshaft from the centres,

and using a suitable copper or aluminium pad and a hammer or soft material work on it till the crankpins are aligned as perfectly as possible. The two crankshaft halves are not set off if both dial indicators give the same readings when rotating the crankshaft. If after this procedure the mutual run-out of the functional parts is greater than 0.016 mm, straighten the crankshaft (its axis) by bending both its halves against each other in the required direction.

This procedure is depicted in Fig. 23. Depending on the deflection of the crankshaft axis (ascertained by dial indicators), bend the flywheels toward each other (— — readings) or away from each other (+ + readings). If necessary, repeat the bending on more planes than the one given in the illustration.

Decisive for the final straightening is the maximum permissible untrue run of the functional part (surfaces) of 0.016 mm. If you fail to obtain this value by the described procedure, it means that the crank mechanism is defective and has to be replaced with a new one. As this work requires great skill, it should be done by a highly qualified fitter.

Fig. 23

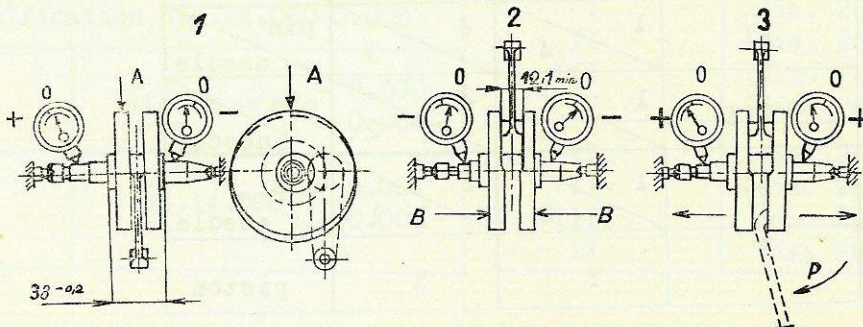

IV. FRAME

1. Front Telescopic Forks

The front fork can be slid out of the frame head after loosening the steering centre bolt. Before refitting the fork thoroughly, lubricate the sliding parts with mineral jelly.

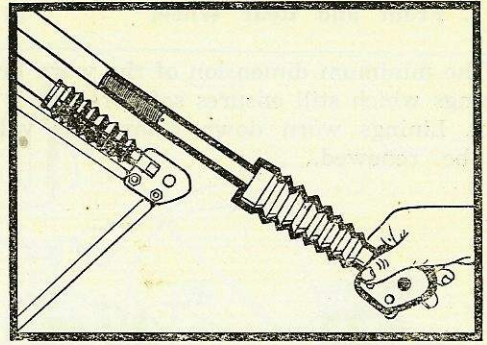
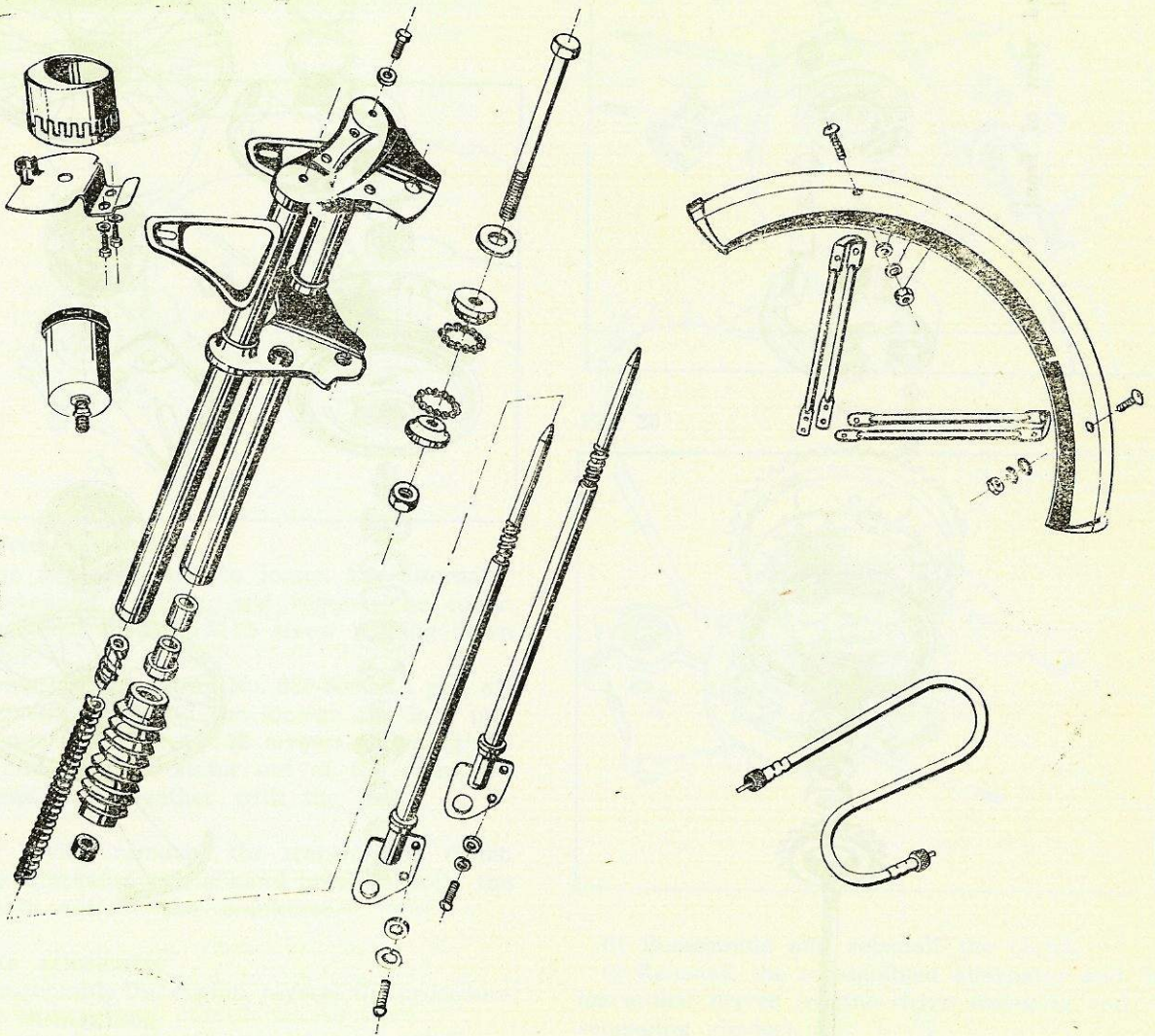

Fig. 24 Removing front telescopic fork slider

Fig. 25 Front telescopic fork



2. Front and Rear Wheel

The minimum dimension of the worn brake-shoe linings which still ensures safe braking is dia. 81.5 mm. Linings worn down below this value have to be renewed.

Fig. 26 Exploded view of front and rear wheel.

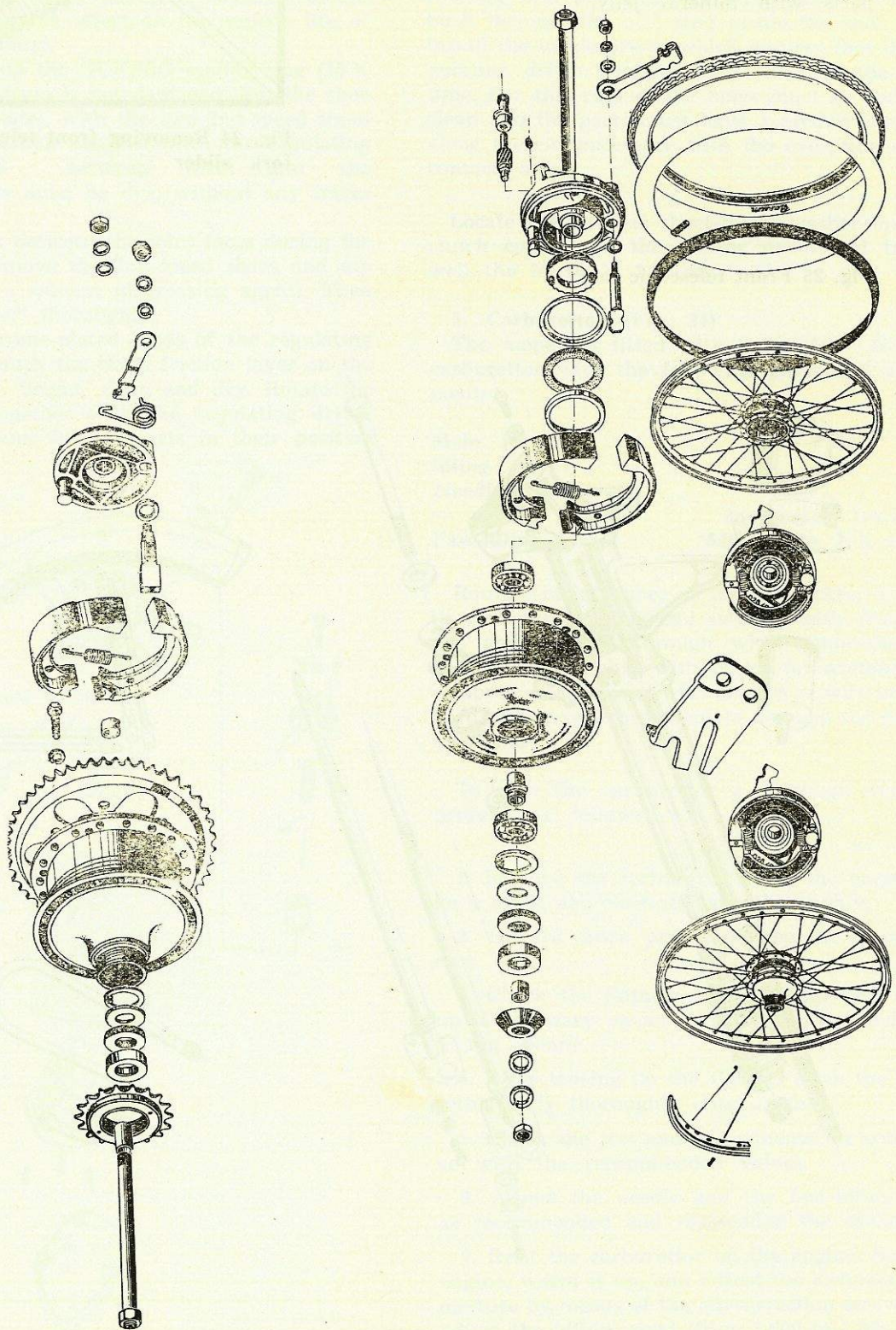

3. Rear Telescopic Suspension Units

The moped is fitted with rear telescopic suspension units of simple design and without shock absorbers. They work with a stroke of 60 mm, and they require no maintenance. To remove them, loosen the two M 8 nuts fastening them to the pins in the frame and to the rear swinging arm.

Fig. 27 Rear telescopic suspension unit.

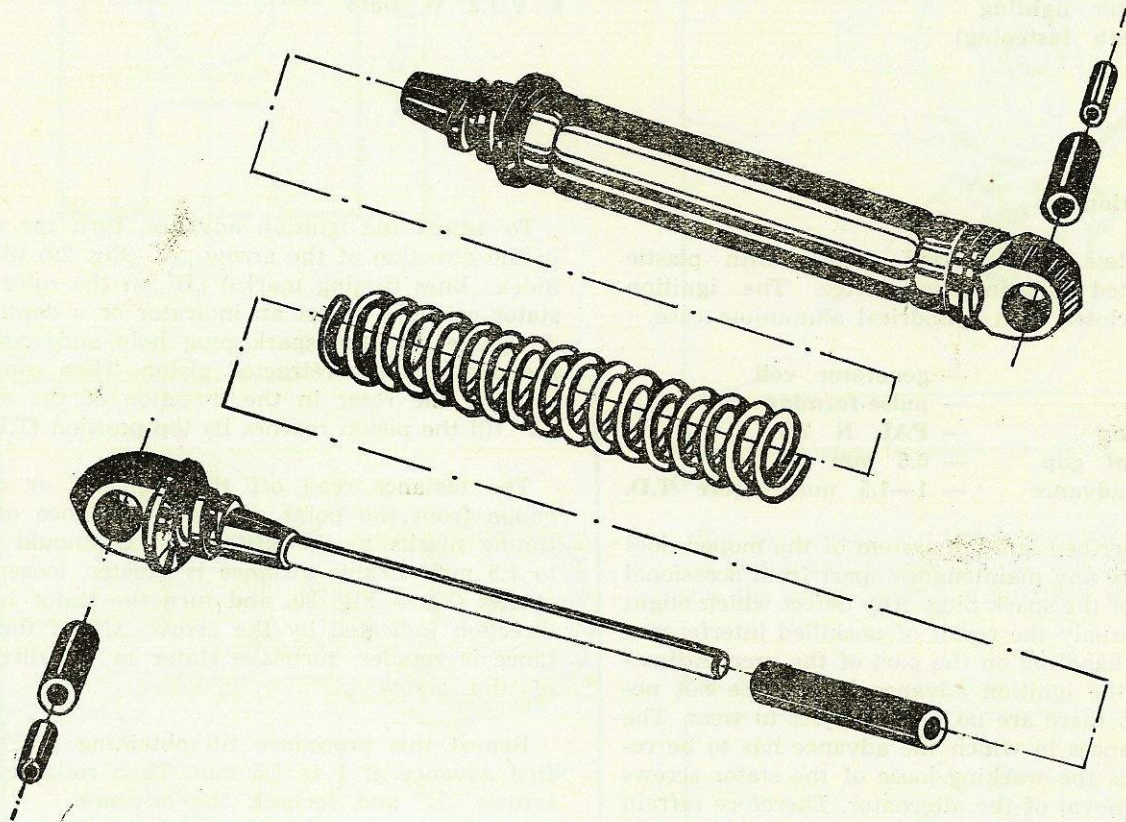

Dismantling telescopic suspension units

- a) unscrew the top spring retaining lug,
- b) screw the spring out of the bottom retaining lug.

Reverse the dismantling procedure to reassemble the telescopic suspension units. Before refitting, lubricate the top lug guide of each unit with lubricating grease.

V. ELECTRICAL EQUIPMENT

1. Alternator

Electric current is supplied by the alternator fitted with a rotor with permanent magnets. The lamps are fed with current from three stator coils

Lamps:

Headlight
Tail light
Speedometer lighting
(outside bulb fastening)
Speedometer lighting
(inside bulb fastening)

connected in series with an output of 20 W at a voltage of 6 V.

Another stator coil supplies current to the ignition coil and the thyristor block controlled by the pulse-forming stator coil.

6 V/21 W bulb

6 V/5 W bulb

6 V/2 W bulb

6 V/1.2 W bulb

2. Ignition

Contactless, thyristorized system with plastic encapsulated semiconductor device. The ignition coil is enclosed in a cylindrical aluminium case.

Feeding — generator coil
Starting — pulse-forming coil
Spark plug — PAL N 7R
Plug point gap — 0.5 mm
Ignition advance — 1—1.5 mm before T.D.

The described ignition system of the moped does not require any maintenance apart from occasional cleaning of the spark plug. Any defect which might occur is usually the result of unskilled interference or rough handling on the part of the user. Adjustment of the ignition advance is likewise not necessary as there are no parts subject to wear. The only instances in which the advance has to be re-adjusted is the working loose of the stator screws or the removal of the alternator. Therefore refrain from interfering with the ignition system in any way. In the case of a defect, have the repair done by a skilled electrician.

To adjust the ignition advance, turn the rotor in the direction of the arrow „A“ (Fig. 29) till the index lines (timing marks) „B“ on the rotor and stator coincide. Insert an indicator or a depth slide gauge into the spark plug hole and measure the depth to the retracted piston. Then continue rotating the rotor in the direction of the arrow „A“ till the piston reaches its top position (T.D.C.).

The distance read off the indicator or depth gauge from the point of the coincidence of the timing marks to the piston T.D.C. should be 1 to 1.5 mm. If this distance is greater, loosen the screws (E) — Fig. 30, and turn the stator in the direction indicated by the arrow „C“. If the distance is smaller, turn the stator in the direction of the arrow „D“.

Repeat this procedure till obtaining the specified advance of 1 to 1.5 mm. Then retighten the screws „E“ and recheck the advance.

3. Moped Wiring Diagram

(is placed on page 30)

Fig. 28 Alternator

The nominal air gap between the rotor and the coils is 0.3 mm.

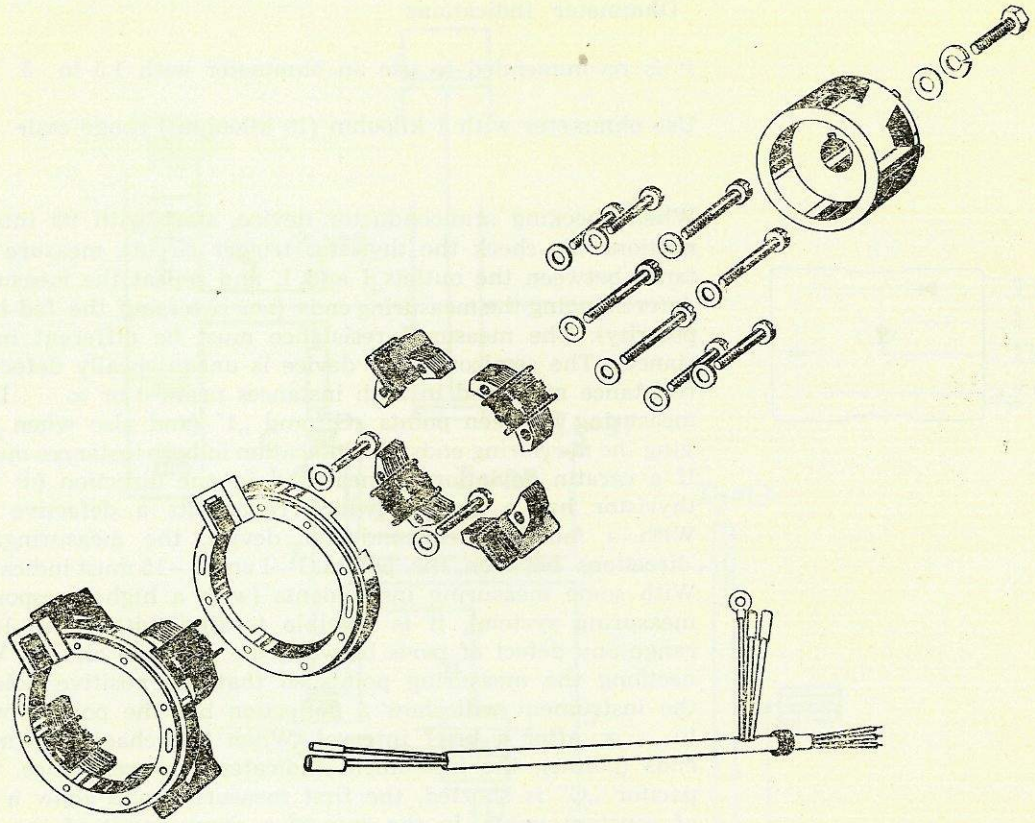

Ignition advance adjustment

Fig. 29

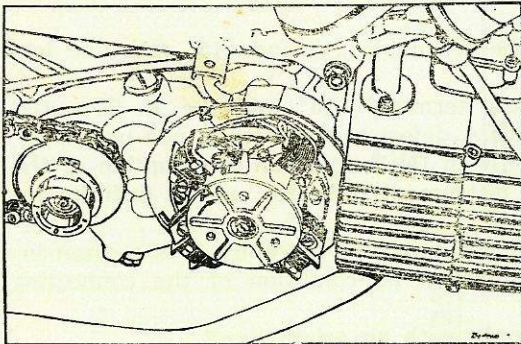
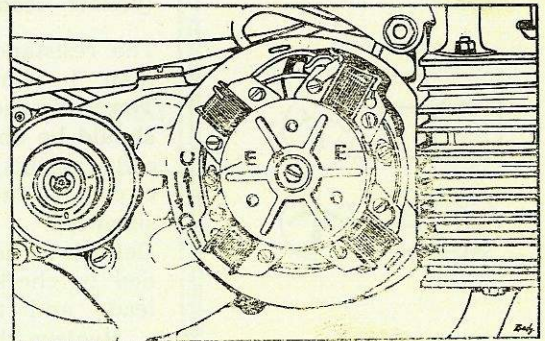

Fig. 30



4. Electronic Ignition Diagnosing Tester

Ohmmeter indications

It is recommended to use an ohmmeter with 1.5 to 3 V in-feed.

Use ohmmeter with 1 kilohm (10 kilohms) range scale.

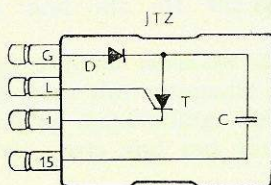

When checking semiconductor device, start with its internal connections. To check the thyristor trigger circuit, measure the resistance between the outlets I and 1, and repeat the measuring after interchanging the measuring ends (i.e. reversing the fed-in voltage polarity). The measured resistance must be different in both instances. The semiconductor device is unequivocally defective if the resistance measured in both instances nears 0 or ∞ . During the measuring between points „G” and „1” (and also when interchanging the measuring ends) the indication in both instances must be ∞ . If a certain deviation is measured in one direction (+ to G), the thyristor has a leakage which represents a defective condition. With a faultless semiconductor device, the measurements in both directions between the points G—I and 1—15 must indicate ∞ . With some measuring instruments (with a higher response of the measuring system), it is possible to find within the 10 kilohm range any defect of parts between the points G and 15. When connecting the measuring points so that the positive pole is to G, the instrument will show a deflection but the pointer will return to ∞ after a brief interval. When interchanging the measuring ends (points), the instrument indicates ∞ resistance. If the capacitor „C” is shorted, the first measuring will show a resistance of constant value. In the case of a short-circuit of the diode, the phenomenon of the first measuring is bound to appear also after the interchange of the points. It goes without saying that in the case of the interruption of „D” or „C”, ∞ would be measured in both directions. We should like to point out that with the phenomenon accompanying the first measuring, the capacitor becomes charged to the voltage of the measuring instrument and the check can be repeated only after the spontaneous discharging of this capacitor which might take several minutes up to an hour.

A faultless ignition pole should give an ohmmeter reading of about 220 ± 10 ohms between pole core, vehicle frame (ground) and pole outlet (red lead).

A faultless pulse-forming coil should give an ohmmeter reading of about 17 ± 1 ohms between the stator carrier and its outlet (yellow lead).

The resistance between the terminals „1” and „15” must be less than 1 ohm.

The resistance between the terminal „15” and the H. T. outlet should be about 6,000 ohms. A defect can be ascertained unequivocally by this measuring only in the case of an interruption of the circuit — the measuring instrument indicates ∞ (infinite resistance).

Defects of the ignition coil are rare and therefore it is recommended to check before its renewal the condition of the connecting leads and terminals.

**Replace the H.T. coil only with an original coil,
Part No. 443 212 210 800 — 4 V.**

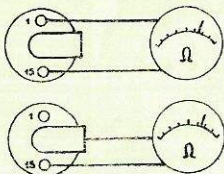

VI. CAUSES OF DEFECTS AND THEIR REMOVAL

A. ENGINE

Engine will not start

1. Shut fuel cock.
2. Empty fuel tank.
3. Choked fuel hose, strainer or fuel jet. Water in float chamber.
4. Faulty ignition — carbon deposits on spark plug electrodes, defective spark plug insulator, excessive plug point gap, defective thyristor device, defective ignition coil or stator carrier.
5. Overflooded engine.

Remedy: Shut off the fuel cock and work the pedals with the machine on its stand or pedal along till the engine fires. Use the decompressor if the moped is fitted with it. Then open the fuel cock. It may also be necessary to unscrew the spark plug and clean it and to turn the engine several times to expell excessive fuel through the spark plug hole. Reinstall the spark plug and repeat the starting procedure.

6. Slipping or defective starting clutch. This you can ascertain by removing the crankcase cover on the ignition side when you will be able to see whether the crankshaft with the rotor is rotating.

Engine runs erratically

1. Overheated engine.
2. Faulty spark plug.
3. Partly obstructed fuel supply or choked main jet.
4. Leaky crankcase.
5. Faulty cable terminal.
6. Faulty ignition.
7. Imperfectly vented fuel tank.

Loss of power

1. Clogged air cleaner.
2. Clogged exhaust silencer.
3. Damaged crankcase sealing ring.
4. Damaged piston, cylinder or piston rings.
5. Leaky cylinder head.
6. Maladjusted ignition advance.

Engine power is satisfactory, but acceleration is poor or peak speed cannot be attained.

1. Brake shoes are fouling the drums.
2. Underinflated tyres.
3. Slipping starting clutch or 2nd-speed clutch.

B. TRANSMISSION

This chapter deals with the less frequent defects which can occur in operation.

As regards identification of causes of incorrect function of the 2nd-speed engaging mechanism, it is assumed that a rider of the specified weight rides on the moped with correctly inflated tyres on a level road in calm weather and that the moped has no contributory rolling resistances as, for instance, maladjusted brakes, and that the secondary transmission mechanisms have not been interfered with, e.g. by exchanging the original sprocket for another one with a different number of teeth.

Defect	Cause	Removal
<p>Engine will not start. Faultless freewheel in rear wheel.</p>	<p>Slipping 2nd-speed clutch 1. Oil on drum friction surface. 2. Water on drum friction surface. 3. Regulating driver (driving dog) clamped between parts does not move and does not expand 2nd-speed shoes. 4. Worn lining of 2nd-speed shoes. Regulating driver strikes against shoe pivot during starting and does not force shoes against drum inner surface.</p>	<p>1. Degrease drum surface and lining 2. Wipe dry drum surface and lining. 3. Work free or renew driver. Possible defect of M 10 x 1.25 nut, e. g. obliquely cut thread. 4. Renew 2nd-speed shoes</p>
<p>Engine starts, but starting is difficult</p>	<p>2nd-speed clutch faultless, indented belt rotates, starting clutch slips. 1. Oil or water on lining. 2. Worn or torn off lining, broken shoe.</p>	<p>1. Degrease or wipe dry. 2. Renew starting shoe.</p>
<p>Engine starts only when pushing down the pedal energetically</p>	<p>Resistances in pedal system (central assembly). 1. Excessive preload of starting shoe springs. 2. Starting shoes move with difficulty. 3. 2nd-speed clutch shoes foul the shoe driver.</p>	<p>Lubricate pedal cranks and shaft and adjust correct tension of chain if it is too taut. 1. Renew or expand springs. 2. Work them free. 3. Work free 2nd-speed shoes.</p>
<p>Rear wheel rotates at idling speed with moped propped on stand.</p>	<p>1. Too high idling speed. 2. GUFERO sealing ring not fully pressed home in small pulley. 3. Starting shoes do not retract fully. 4. Starting shoes driven mostly when starting clutch is warmed up. Probably interchanged shoes.</p>	<p>1. Decrease idling speed. 2. Press sealing ring home (flush with pulley). 3. Check chamfering of leaf spring edges. 4. Install shoes in their correct place.</p>
<p>Slipping starting clutch.</p>	<p>1. Worn friction lining.</p>	<p>1. Renew shoes.</p>

Defect	Cause	Removal
<p>Engine starts and runs, starting clutch in good working condition but moped does not start moving in first gear or moves for only a brief period and then force closing is interrupted. Sometimes force closing is restored when decreasing engine speed.</p> <p>When starting off at full throttle on level road, engine overspeeds in first gear. This may not necessarily be considered a defect.</p>	<p>1. Freewheel in engine does not engage firmly.</p> <p>2. Damaged — worn face for freewheel rollers.</p>	<p>1. Change oil in transmission. Use oil of lower viscosity in frosty weather.</p> <p>2. Renew freewheel gear.</p>
<p>When starting off at full throttle on level road, the engine fails to attain the required speed in first gear and soon changes to the 2nd gear.</p> <p>This is normal when riding downhill because of decreased rolling resistances.</p> <p>Changing from 1st to 2nd gear takes longer than normally.</p>	<p>1. 2nd-speed shoes move sluggishly.</p> <p>2. Increased frictional resistance between regulating driver and shoe brass layer.</p> <p>3. Engine has an output surpassing the recommended output or a different torque characteristic.</p>	<p>1. Work them free.</p> <p>2. Burnish hard chrome-plated lands on regulating driver, or renew the driver. Never lubricate contact areas as friction dampens vibration of 2nd-speed shoes in final gear-change stage.</p> <p>3. Not considered as defect as long as moped peak speed is observed.</p> <p>— Accelerate with only partly open throttle.</p>
<p>When starting off at full throttle on level road, the engine fails to attain the required speed in first gear and soon changes to the 2nd gear.</p> <p>This is normal when riding downhill because of decreased rolling resistances.</p> <p>Changing from 1st to 2nd gear takes longer than normally.</p>	<p>1. Insufficient engine power, moped often cannot attain its specified peak speed.</p>	<p>1. Proceed as per section „Loss of power.“</p>
<p>When starting off at full throttle on level road, the engine fails to attain the required speed in first gear and soon changes to the 2nd gear.</p> <p>This is normal when riding downhill because of decreased rolling resistances.</p> <p>Changing from 1st to 2nd gear takes longer than normally.</p>	<p>1. First to fourth gear change takes longer because of cold clutch which has not yet attained its normal service temperature.</p> <p>2. Oil or grease on regulating driver and shoe contact areas. Light vibration might occur in final stage of 2nd gear engagement.</p>	<p>1. Not regarded as defect.</p> <p>2. Degrease.</p>

Defect	Removal	Cause
<p>Changing from 1st to 2nd gear takes very long or it does not take place at all. When the 2nd speed clutch is sliding it is not allowed to drive more than 1 km. High temperature can reduce the lifetime of driving belt.</p>	<p>Slipping 2nd speed clutch. 1. Dirt or oil on friction areas. 2. Water on friction areas. 3. Interchanged 2nd-speed shoes. It is also possible that the lining touches the drum on the less effective trailing side.</p>	<p>1. Remove dirt, degrease drum and linings with suitable degreasing agent. Then run in the clutch (formation of final friction layer). Find cause of contamination (defective GUFERO sealing ring, O ring, burrs). 2. Without dismantling dry the clutch by letting it slip. 3. Replace shoes correctly or wait till lining settles down on the whole working surface. Gears have to be changed about 20 to 25 times before a new lining, made so that it touches the drum on the leading edge, has settled down to enable the function of the whole working surface.</p>
<p>Changing from 1st to 2nd gear takes a shorter time than normally or a very short time. Exceptionally, the moped even starts from rest in 2nd gear or a change from 2nd to 1st gear takes place when riding uphill.</p>	<p>Imperfect control of retraction of 2nd-speed shoes by regulating driver. 1. Check movability of inner driver (regulating driver) contact under load. Hard chrome-plated lands on inner driver must be bright and undamaged.</p>	<p>1. This defect can be identified and also removed by replacing inner driver with a new one.</p>
		<p>Changed properties of this contact can also be brought to light by a comparison test of 1st-to-2nd-gear change under load (at full throttle): A) Moving along in 2nd gear, decelerate by applying the brakes to change down from the 2nd to the 1st gear. After releasing the brakes, the transmission will change smoothly from the 1st to the 2nd speed. B) Then decelerate by throttling down. This will release the regulating driver which will turn to the opposite side. On acceleration, the changing up from the 1st to the 2nd gear is different — more sudden than in point A). This indicates that the regulating driver does not set readily on the inner driver and that the contact areas (lands) are not in satisfactory condition.</p>

Defect	Removal	Cause
	<p>2. The inner driver must turn and bear against the working surfaces with a certain peripheral clearance.</p> <p>3. Defective chromium layer between regulating driver and brass layer on clutch shoe and or destroyed brass layer. Oxides formed there by pressure increase friction between the parts.</p> <p>Other harmful factors:</p> <p>4. Increased humidity of air in the space of clutches.</p> <p>5. High working temperature of 2nd-speed clutch built up by changing gears in rapid succession (fifteen and more times).</p> <p>6. Thick layer of particles of abraded friction material in the form of scales covering the working surface.</p>	<p>2. Renew the parts. It is not recommended to thin down faces of the parts by grinding.</p> <p>3. Renew regulating driver, renew shoe.</p> <p>4. Heat the space of clutches by a short ride without changing gears. After every washing of the moped, start the engine and let it warm up.</p> <p>5. A 10- to 15-second ride will suffice to restore the original properties of the clutch. This is actually no defect but a normal property of friction linings.</p> <p>6. Find and remove the cause of lining abrasion. Remove the layer mechanically, for instance with fine abrasive (emery) paper, taking care not to change the shape of the settled down (bedded) lining.</p>

Optimum gear change in model 210 moped, 2nd gear — 40 km/hr. at full-throttle acceleration.

(2nd speed clutch warmed up to service temperature).

After starting from rest, the 2nd gear is engaged within a distance of 26 metres.

Permissible gear-change tolerance limits: +30 m, —5 m.

Engagement of 2nd gear begins at a distance of 18 metres and is completed in about 1.5 to 2 seconds.

A cold 2nd-speed clutch prolongs the distance by 9 metres (first to fourth gear change).

An overheated 2nd-speed clutch shortens the distance by 3 metres.

According to speedometer readings, the moped should attain about 24 km/hr. in 1st gear at full throttle and the change to the 2nd gear should be completed at a speed of about 28 km/hr.

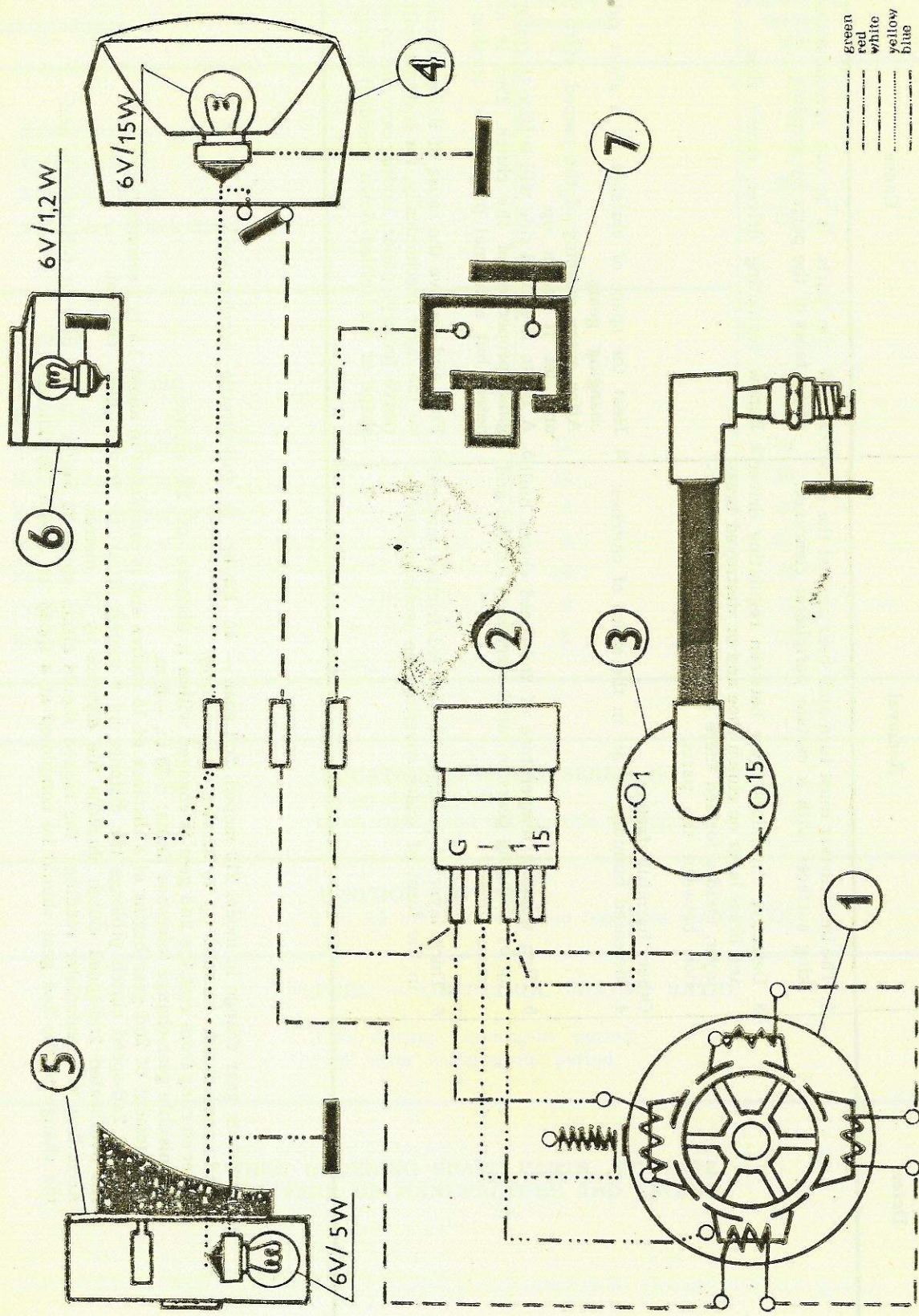

Wiring Diagram
 1. Alternator 2. Thyristor ignition unit 3. Induction coil 4. Head lamp 5. Tail lamp 6. 6V/12W lamp 7. Ignition switch off

