

ABG VAP 57

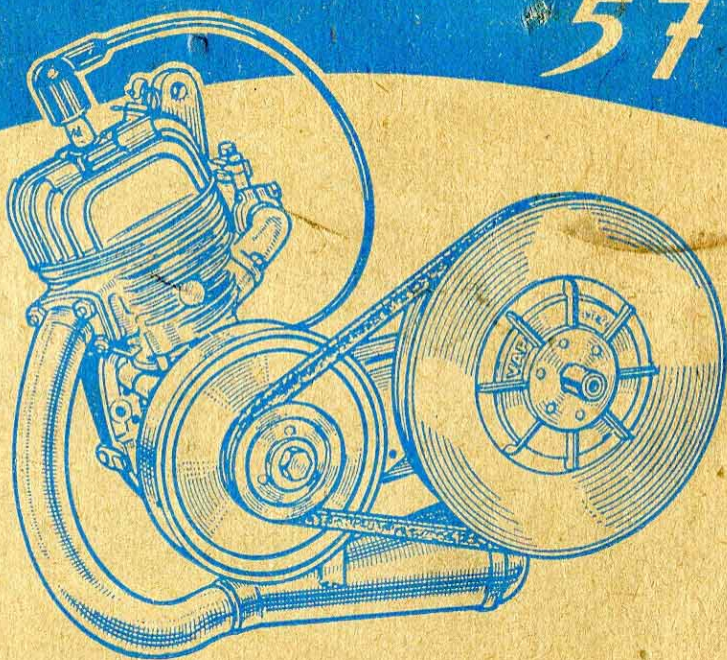

ABG VAP MOTOR, Type 57
Progressive Automatic Clutch
Ignition and Lighting with "MAGNECLAIR"

INSTRUCTION BOOK

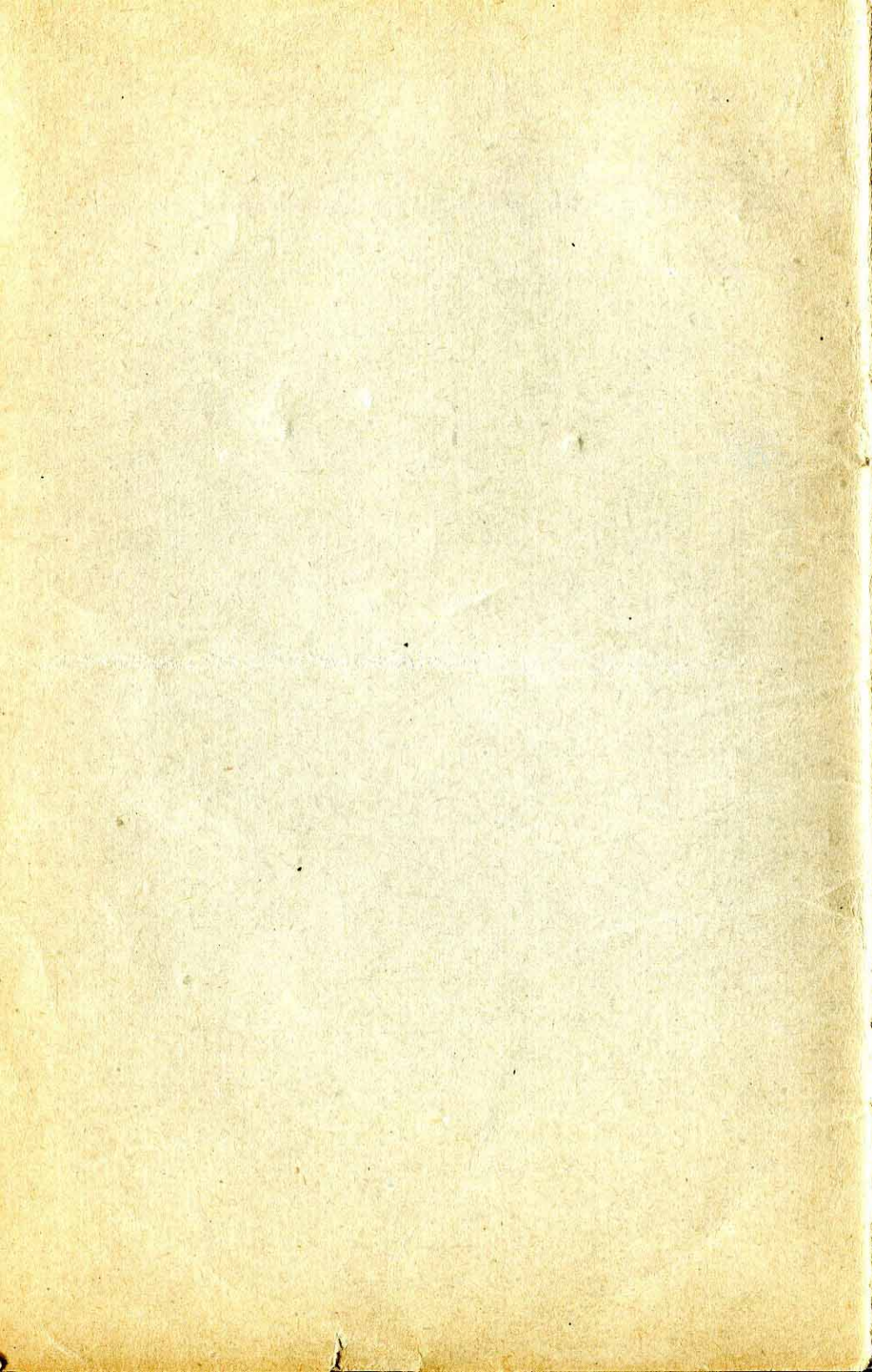

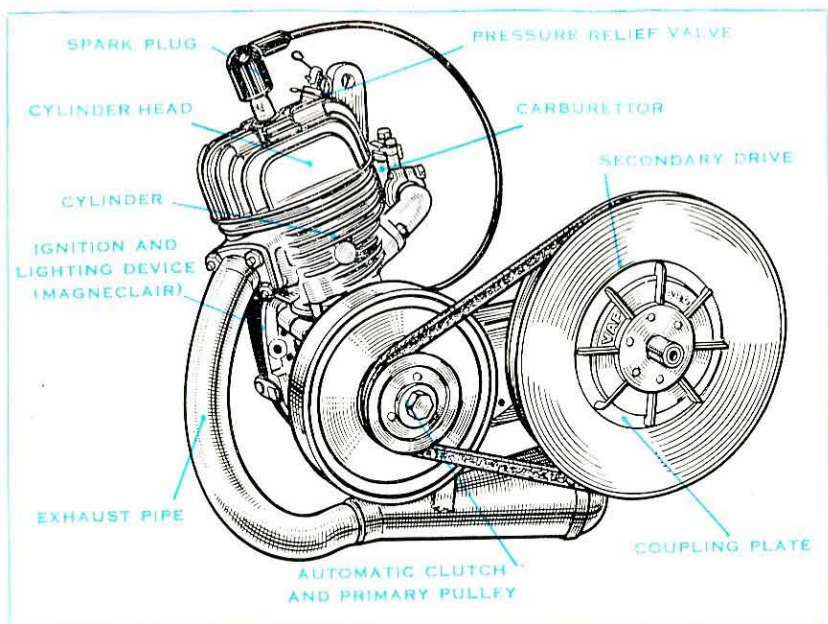

ABG VAP MOTOR TYPE 57
WITH
PROGRESSIVE AUTOMATIC CLUTCH

ABG
VAP 57

FOREWORD

Always ready to go into service, VAP 57 motor, main component of your "moped", is willing to take you anywhere (town duty or hilly country) at a picked-up speed, without pedal straining job. It as been designed so that a minimum of attention is required to keep it in satisfactory running order and to get an optimum performance out of it.

Following instructions have been laid down for such a purpose, and if they are carefully read and followed, you will thus be convinced of the superiority of our VAP 57 production.

DESCRIPTION

The VAP 57 is a one-cylinder, air cooled engine of 48 cc. capacity, whose main characteristics are:

Bore.....	40 mm
Stroke	38 mm

This engine operates on the two stroke (two cycle) principle. It is of the twin transfer type, with ports out of casting in the cylinder and precompression in the crankcase. It is a single speed engine with **progressive automatic clutch**, known as «**self-starter**»; ignition and lighting being assumed by a device of our exclusive design, named the «**Magneclair**».

MAIN COMPONENTS OF THE VAP 57

A) **The engine itself** including:

1. **Cylinder and crankcase:** The cylinder is of special cast iron alloy without any lining.
2. **Piston and connecting rod assembly:** The connecting rod small and big ends run on needle blocks and the crankshaft on ball bearings. Piston is of light alloy.
3. **Progressive automatic clutch:** The automatic clutch is of the centrifugal type: it includes a strongly built free wheel for starting the engine, and two lined shoes coming into engagement as soon as the engine revolutions reach 2000 r.p.m. A grooved pulley is also included for the primary drive through a rubber «V»-belt.
4. **The «Magneclair»:** Ignition and lighting are ensured by a new system of our exclusive design «The Magneclair», mounted on one face of the engine crankcase; the stator (fixed component) is secured on the crankcase, and the rotor (rotating part) being keyed on the crankshaft. Such a design offers the valuable advantage of accessibility, easy dismantling and being at the same time dust-and-water-proof.
5. **Carburettor:** The VAP 57 engine is equipped with a GURTNER D. 12 carburettor, including a float chamber, a main jet, a throttle-slide, an intake filter and an idling adjustment screw. This screw is very accessible from the outside and permits a perfect slow-running or idling adjustment, a very valuable feature much appreciated by the users.

This adjustment is very sensitive, also care must be taken when operating the screw. Initial setting is made in our factory.

This carburettor also include an automatic device to bring the throttle from the starting position to normal operating position.

To operate the starter proceed as follows:

For cold start:

With **GURTNER D. 12**: Shift towards left the small lever located on the intake silencer until it engages under the small leaf-spring.

For starting the moped: Slightly open the throttle, about $1/3$ of the total rotation of the throttle control handle.

After a pedal run of about 50-100 yards according to the environment, turn quickly the throttle control handle to clear out the starter (choke) operation and return to normal throttle position.

B) **The secondary drive**, mounted on the crank axle and including :

1. **A grooved pulley** of large diameter.
2. **A 12 teeth sprocket**, which may be coupled to the pulley by means of a very simple ratchet device.
3. **A coupling plate**, workable **ONLY** with **MOPED STOPPED**, which engages or releases the engine to/from the cycle drive at each $1/8$ of a revolution. Eight marks engraved on the pulley avoid any faulty operation.
4. A « **V** » **belt** for the power transmission to the secondary geared down pulley.
5. Final transmission to the rear wheel is made by a conventional chain.

C) **Controls.**

The handlebar carries all the engine controls :

1. **Throttle control**, operating the throttle slide of the carburettor by means of a cable, whose minimum travel is 14 mm. (about $9/16''$).
2. **The compression relief control** connected by a cable to the yoke of this device which allows the opening or the closing of its valve. Minimum travel for this cable is 10 mm. (about $25/64''$).

RIDING THE CYCLOVAP 57

BEFORE UNDERTAKING ANYTHING :

You have to run-in your engine

The running-in period must extend over a **MINIMUM DISTANCE** of 500 Km (310 Miles).

DURING THE RUNNING-IN PERIOD:

Never exceed 35 Km per hour (22 m.p.h.) on flat.

Give pedal assistance to the engine when starting or going up hill.

For the lubrication: mix 10 % **MOTUL MIX COURSES** oil to the petrol (The use of high grade petrol must be avoided).

AFTER THE RUNNING-IN PERIOD:

The riding of your cyclo VAP 57 must be carried out according to the following instructions:

The proportion of the **MOTUL MIX COURSES** oil to be mixed with the petrol is to be reduced to 7 or 8 % (This is very important).

By steep hill-climbing, when the speed of your cyclemotor decreases without any fading of the engine power, never hesitate to give pedal assistance when the speed drops under 22/25 Km per hour (14/16 m.p.h.).

This strain is slight and is very usefull to unload the engine which, for speeds below 18 Km/h (11 m.p.h.), is not cooled enough by the relative air stream.

Therefore pedal assistance compensates for the lack of cooling under full load operation.

Running on flat or moderate hilly countries, does not need any special care. However full throttle opening for a long while is to be avoided. The VAP 57 engine can afford speeds up to 50 or even 55 Km per hour (31/34 m.p.h.) but such figures may be reached exceptionally; normal speed is of about 40 Km/h (25 m.p.h.).

A) COLD STARTING:

Proceed as follows:

a) **Fill up the tank** with a mixture of ordinary petrol (gasoline) and **MOTUL MIX COURSES** oil at 7 % (10 % for running-in). For this operation refer to the section of this book dealing with lubrication.

b) **Chek if the engine drive is coupled to the cyclemotor:** To check this, push the cycle motor by hand, if you feel some resistance, coupling is «on»; if not, give 1/8 th. revolution to the coupling plate mounted on the crankwheel spindle just in front of the secondary drive pulley; this operation may be done either by hand or by the toe. When the noise of a steady engagement is heard and the fins of the coupling plate are lined up with the marks on the pulley, the coupling is «on».

c) **Open the petrol tap.**

d) **Close the air choke (or cold starting flap)** as explained in the description of the carburetors (in very hot weather it must be let open); ride the cyclemotor; slightly open the throttle (1/3 rd of the twist grip travel) and pull on the compression relief lever. Give 3 or 4 revolutions to the pedals, then release the compression relief lever, the engine should start immediately.

e) **Further open the throttle** and still pedal until reaching 18 km/h (11 m.p.h.).

f) After a travel of about 100 yards, open the throttle at full position, the cyclemotor will then accelerate.

B) STARTING WITH ENGINE WARM:

Proceed as specified above, except for:

- The operation of the air choke, and
- The operation of the throttle, which can be fully opened as soon as the engine is running.

Caution. — Once accustomed to the cyclo VAP 57, pedal starting may be replaced by something easier. A quick push of the cyclemotor, together with slightly opened throttle, is quite sufficient to start the engine, this is particularly appreciated by hill-climbing starting.

C) TEMPORARY STOP (red traffic light for instance):

Reduce the throttle and apply the brakes until stop.

The engine is then automatically disengaged but still slow-running without driving the cyclemotor. For re-starting, open steadily the throttle, the cyclemotor will then start progressively, however some pedal assistance is necessary to avoid excessive wear by slipping of the clutch.

D) FINAL STOP:

Fully close the throttle and operate the compression relief lever. Close the petrol tap.

E) TRANSFORMING THE CYCLEMOTOR INTO A PEDAL CYCLE:

While at stop, give the coupling plate $1/8$ th of a revolution in any direction, the coupling plate being located in front of the secondary pulley; thus, the cycle is no longer in engagement with the motor.

LUBRICATION

1) ENGINE LUBRICATION

The engine is lubricated by a mixture of **MOTUL MIX COURSES** oil with ordinary petrol (or gasoline). The petrol mixture must be very homogeneous, it should be made in a separate container. Steadily shake it before pouring into the fuel tank of the cyclemotor. Filtering the petrol, whenever possible, is a highly recommended practice.

Correct proportions for the petrol mixture:

For normal lubrication of the engine, add to the petrol volume a quantity of **MOTUL MIX COURSES** oil corresponding at 7-8 % of said volume; but during running-in period, such quantity must be raised up to 10 %. The normal colour of the exhaust smoke is slightly blue; but the overlubrication when running-in results in a heavier smoke.

II) AUTOMATIC CLUTCH LUBRICATION

The needles and the free wheel of the automatic clutch are definitely greased at the factory and do not, normally, require any further lubrication. However, every 2000-3000 km (1200-1900 miles), and mainly when riding in rough weather, the primary drive pulley may be removed and cleaned. When fitting it back again, never miss to grease the needles and the free wheel with a high melting point grease (temperature about 150° C-302° F), the grease used must not be very adhesive (use MOTUL n° 5039 grease).

From time to time, mainly when riding in rain, pour one drop of oil behind the lockwasher of the screw which is located at the protruding end of the crankshaft.

III) SECONDARY DRIVE LUBRICATION

a) **Internals parts:** The lubrication of those parts, carried out at the factory, can last for many thousand miles. If necessary, use for this a very sticky heavy grease, whose melting point must be more than 80° C (176° F).

b) **Pedal crank spindle:** With a grease-gun engaged in the grease nipple provided for the purpose, fill the grease recess. The grease may be of either make, however MOTUL 850 S is recommended.

Caution. — If the cyclemotor is always used with its engine drive, the above process of pedal crank spindle greasing may last for many thousand miles, even in hilly country where pedal assistance becomes necessary. But when the cyclemotor is more often used as a pedal cycle, greasing must be done more frequently; the necessity for this operation is easily noticed by the increasing resistance to the action of the pedals.

MAINTENANCE AND ADJUSTMENTS

Keep your engine as clean as possible, this is a « must ».

1. **Check nuts tightening:** In the case of a new or overhauled engine, inspect all the nuts of the cylinder and cylinder head for tightness; they must be screwed home, but not overtightened.
2. **Decarbonising:** After a period which varies according to the riding conditions, the quality of the oil and petrol used, the engine gets « coked »; the top of the piston, the cylinder head, the ports, are then coated with a layer of carbon. If this layer becomes too heavy, jerky engine operation and consistent loss of power will result. The decarbonising is to be undertaken normally every 1 000 miles, and if possible by a specialized mechanic.

The first decarbonising of a new or overhauled engine must be done after the first 300 miles of the running-in period.

3. **Maintenance and adjustments of the «Magneclair»:** Every 2000 miles, remove the cover and inspect the inside for cleanness. If necessary clean the contact-breaker with petrol free of oil.

If the instrument is correctly timed, the breaker contacts start opening when the piston top is at 3-3,2 mm before the top dead center. Timing may be adjusted by shifting slightly the stator after releasing of the two fixing screws located under the coils.

At maximum opening, the distance between the contacts must be 0,25 to 0,30 mm (.010" to .012"). Never drop oil on the breaker cam, the lubrication ensured by the felt at the factory may last over 8000-10.000 km (5.000-6.000 miles).

If the felt is too dry, it must be impregnated with very heavy grease.

4. **Lighting:** The lighting coil of the MAGNECLAIR is provided for a 6 Volts 1 Ampere bulb at the front and 12 Volts 0,5 ampere bulb at the rear.

WARNING. — Never let the lighting switch «ON» with the total current on the rear bulb alone, its «life» being a function of this observation. Carefully check the bulbs for tight fit. One loosen bulb will result in the defection of the other. For the same reason replace a defective bulb as soon as possible.

5. **Spark plug.**

The gap of the spark plug electrodes must be cheked every 900-1.200 miles or more frequently if any trouble is felt; also inspect for cleanness; the correct gap value is .016"/.024". Carbon deposits must be removed with a small metal wire brush.

CAUTION — The VAP 57 engines are delivered with a «soft» (hot) plug in order to avoid fouling during the running-in period. The same plug may be maintained if the rider is not a «rough going fan», but for some one who looks after high speeds, a «hard» (cold) plug of the same make becomes necessary.

6. **Belt tension adjustment.**

At stop, the rubber belt must not show any deflection.

Under the finger pressure, deflection must be of about 1 centimeter (25/64").

Tension adjustment is carried out by swivelling the engine around its upper fixing point.

The «A.B.G.» concern will, on request, supply a special belt tension checking straight edge, under the reference number 36. Also is supplied for the purpose a special wrench, under the reference number 51, which makes the belt adjustment still more easy.

7. **Clutch adjustment.**

The clutch is definitely adjusted at the factory. Further repair, if any, must be made by our representatives.

SOME INSTRUCTIONS

We may draw again your attention on the main feature of the VAP 57 engine: its automatic progressive clutch. For slow going, under 10 m.p.h. the clutch can slip, and this is very valuable in town traffic; however we always recommend to give pedal assistance in such cases. At speeds over 10 m.p.h. the clutch must not slip: if it does, this is surely due to a loss of power of the engine; trouble must be located and eliminated.

Two cases are possible:

1. Engine fading either warm or cold.

This may occur during the running-in period, by lack of bedding of the engine components. In fact, many hundreds of miles riding are necessary before getting full power.

If after this period the engine is still fading, inspect:

- a) **The spark plug.** Which may be either too soft (white electrodes) or too hard (fouled electrodes). Then the plug must be replaced by one of the correct grade.
- b) **The carburettor.** Clogged (obstructed) filter. Leakage to the needle valve.
- c) **The magneclair.** Defective timing. Defective contact breaker gap.

In addition, the loss of power may result from:

- d) **A defective decarbonising:** Inspect the cylinder ports and the inside of the silencer.
- e) **A defective belt tension,** which must be inspected for the first time after 60 miles, then after 300 miles, and later periodically every 600 miles for instance.

2. Engine fading when warm only, i.e. after a full throttle ride for a long period and on bad roads.

In this case the trouble is almost always resulting from pre-ignition, due to overheating which brakes the motor.

If this trouble is unusual, let the engine cool by reducing the throttle opening for a few minutes and give pedal assistance.

If the trouble occurs frequently, proceed as follows:

- a) Inspect the piston and cylinder head for carbon deposits. Inspect the cylinder head nuts for defective tightening.
- b) Inspect the piston for piston rings sticking.
- c) Try a harder (colder) spark plug (Mind the grade).

NOTICE FOR THE CARBURETTOR

GURTNER " D 12 "

The twist-grip controls the throttle slide for normal operation. The starter handle controls the closing of the air-choke for cold starting.

It is absolutely necessary to close the throttle-slide for operating of the air-choke.

Use the air-choke (starter) only for cold-starting of the motor; when started, accelerate slightly and after a few instants (this being a function of the ambient temperature), give a sudden accelerating stroke to release the starter.

To ensure a smooth operation, the carburettor must be vertical accurately mounted, with the clamping collar firmly secured on a tight fit. Air and fuel filters must be perfectly clean.

To remove the throttle slide, loosen the cap screw and take out the throttle keeping it upright (do not lose the throttle slide spring and the releasing spigot). Compress the spring against the cap, turn the throttle slide guiding lug and unhook the throttle.

For re-assembly, after the cable end-piece is passed through, check if the throttle slide guide is correctly located and seals the throttle slide slit. Clean the float chamber at regular intervals, proceeding as follows:

- disconnect the fuel inlet union,
- loosen the cover screw,
- pivot the clamping part and take off the cover,
- remove the float (take care, part very fragile),
- clean the float chamber with petrol and rinse,
- clean the fuel inlet strainer and the air filter.

CARBURETTOR GURTNER TYPE D 12 - D 421 A B G

Spare parts list

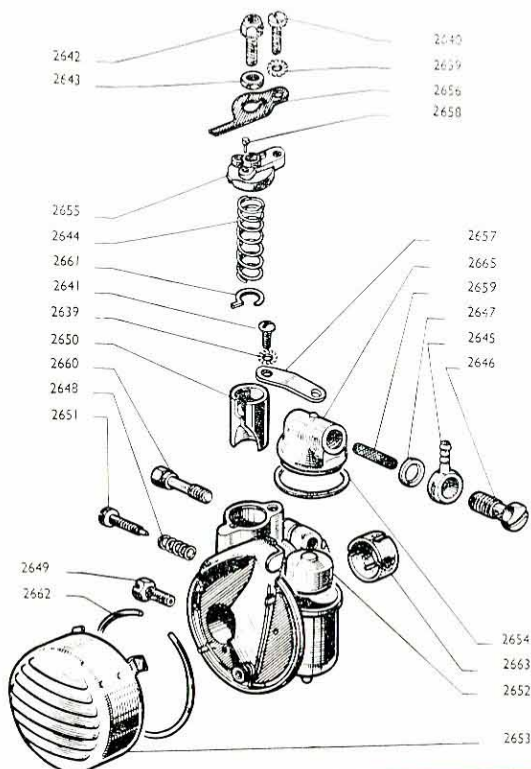

A.B.G. Ref. N ^o	DESCRIPTION	A.B.G. Ref. N ^o	DESCRIPTION
2639	Washer	2654	Gasket - Float chamber
2640	Screw - Upper Cap fixing	2655	Upper Cap
2642	Bolt - Tension	2656	Starter Locking plate
2643	Lock Nut	2657	Leaf spring - Cover
2644	Spring - Throttle slide	2658	Releasing spigot
2645	Union - Banjo type	2660	Collar clamping screw
2646	Screw - Inlet Union clamping	2661	Throttle slide guide
2647	Gasket	2662	Circlip
2649	Jet	2665	Cover - Float Needle
2648	Spring - Stop screw	2653	Air Filter
2663	Sleeve-thermalinsulating	2659	Fuel Strainer
2650	Throttle slide	2641	Screw - Cover leaf-spring clamping
2652	Float	2651	Stop screw - Throttle slide

CARBURETTOR GURTNER TYPE D 12 - G 479 A B G

Spare parts list

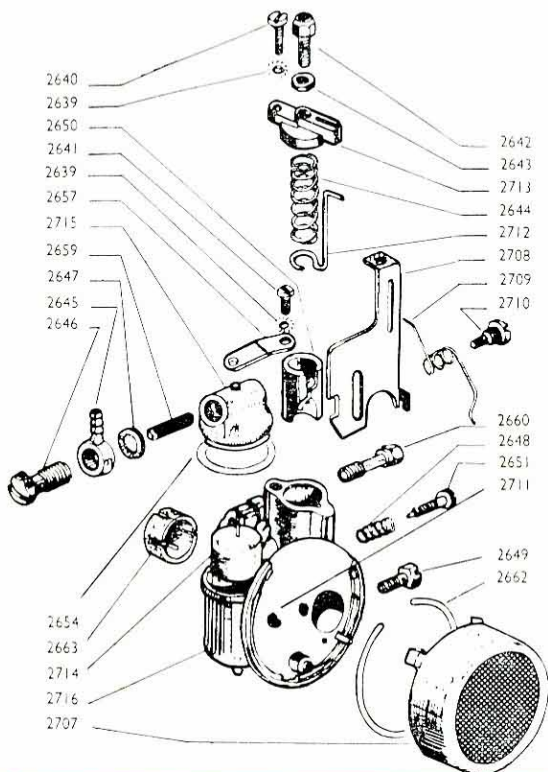

A.B.G. Ref. Nr	DESCRIPTION	A.B.G. Ref. Nr	DESCRIPTION
2639	Washer	2648	Spring - stop screw
2640	Screw - Upper Cap fixing	2663	Sleeve - thermal insulating
2642	Bolt - Tension	2654	Gasket - Float chamber
2643	Lock Nut	2657	Leaf spring - Cover
2644	Spring - Throttle slide	2660	Collar clamping screw
2645	Union - Banjo type	2662	Circlip
2646	Screw - Inlet Union clamping	2712	Releasing Spigot
2647	Gasket	2713	Upper Cap
2707	Air Filter	2659	Fuel Strainer
2708	Air throttle slide	2714	Float
2709	Return Spring	2641	Screw
2711	Stop finger	2651	Screw - Throttle-slide stop
2710	Screw - Air throttle slide clamping	2716	Carburettor Body
		715	Cover - Float Chamber
2649	Jet	22650	Throttle slide

MAGNECLAIR

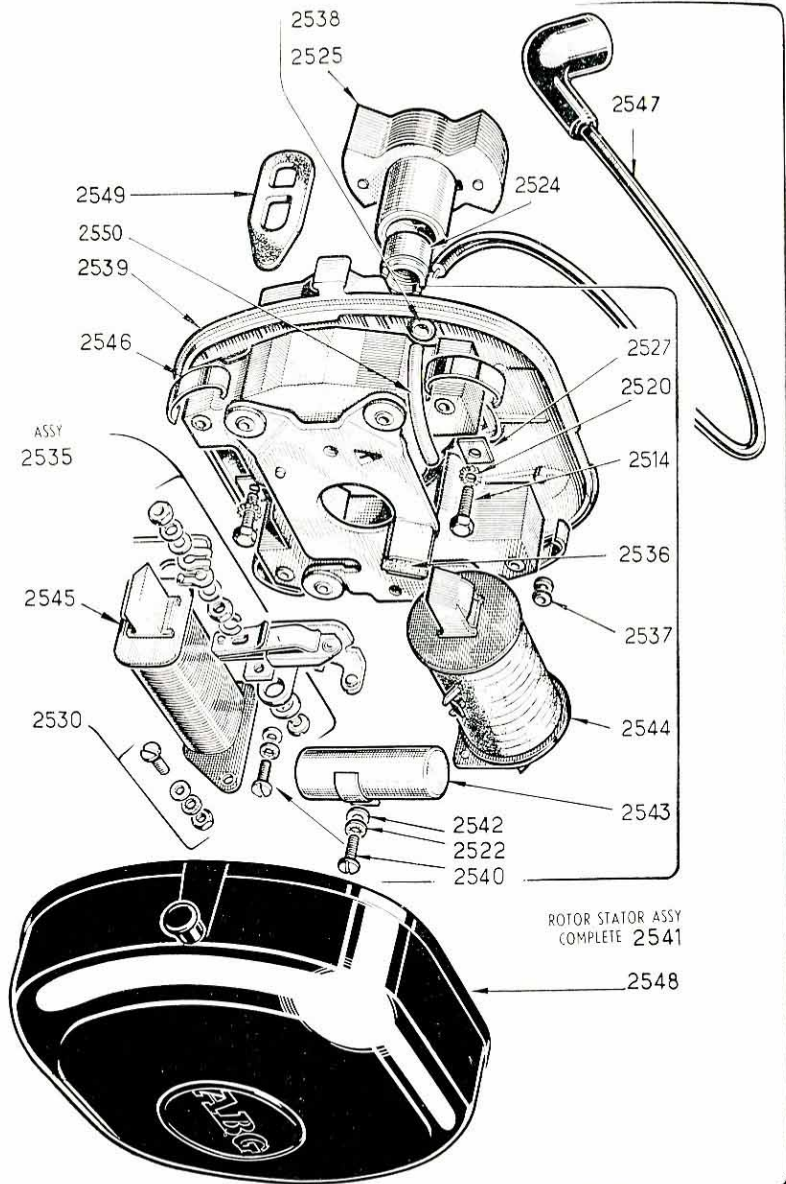

MAGNECLAIR ASSY COMPLETE 2531

Spare part
list

Ref. Numb.	DESCRIPTION	Quant. per unit
2531	MAGNECLAIR assembly complete, including ...	1
2525	Rotor complete	1
2541	Stator complete, including:	1
2539	Stator proper	1
2538	Rubber grommet (High Tension ignition wire)	1
2536	Felt-greasing	1
2537	Rubber grommet (Lighting wire)	1
2535	Contact breaker, complete	1
2540	Screw - Contact breaker fixing	1
2542	Washer - plain: 4,2 × 8 × 0,8	1
2522	Washer - spring lock	1
2543	Condenser	1
2540	Screw - Condenser fastening	1
2542	Washer - plain: 4,2 × 8 × 0,8	1
2522	Washer - spring lock	1
2544	Coil - ignition	1
2545	Coil - lighting	1
2546	Spring - coils fixing	4
2547	Wire - spark plug	1
2548	Cover	1
2549	Rubber pad - cover attaching	2
2524	Nut - rotor fixing	1
2514	Screw - stator fixing	2
2515	Plate - stator fixing	2
2521	Spring lockwasher, outer splines	2
2526	Protective sheath - spark plug ignition wire..	1
2530	Terminal - lighting wire	1

SPARE PARTS LIST FOR « VAP 57 » ENGINE

For any order or inquiry kindly mention the serial number punched on the front side of the crankcase. For example : 363.210 - VAP 57.

Reference Number	DESCRIPTION	Quantity per unit
	ENGINE UNIT, including	1
2501	a) Crankcase complete, including	1
	Crankcase proper, including	1
2500	1/2 crankcase, Magneclair side, complete including	1
	1/2 crankcase, Magneclair side, proper	1
109	Stud - cylinder	2
2293	1/2 crankcase, driving pulley side, complete including	1
	1/2 crankcase, driving pulley side, proper	1
109	Stud - cylinder	2
2296	Gasket - Two 1/2 crankcase	1
2502	Screw 6 mm dia. 60 mm long) For:	2
2295	Screw 6 mm dia. 56 mm long) Two 1/2 crankcase assembly	3
2148	Washer - plain: 6,25 × 10,25 × 0,8	2
2220	Washer - grower: 6 mm dia.	5
503	Nut - Hex: 6 mm dia.	5
2297	« PAULSTRA » gasket: 15 × 30 × 4,5	2
2260	Fixing ferrule - lower	2
2511	b) Connecting rod assembly complete, including	
2509	1/2 assembly, including	
2508	Assembly proper including	
	Connecting rod	1
	Crank pin	1
	Needle - big end (2,5 × 9,8)	22
	Washer - big end	2
	1/2 crank shaft, pulley side	1
	1/2 crank shaft, « Magneclair » side	1
2015	Washer - thrust	2
153	Piston pin	1
155	Needle - small end (2 × 9,8)	19
156	Washer - small end	2
162	Ball bearing No. 6202 (15 × 35 × 11)	2
2331	c) Piston complete, including	1
	Piston - spigotted, including	1
	Piston proper	1
	Spigot - piston	2
2223	Ring - piston compression	2
206	Circlip 12 mm inner dia.	2
2311	d) Cast iron cylinder complete, including	1
	Cylinder proper	1
240	Stud: 5 × 12	6
252	Gasket - cylinder	1
2316	e) Cylinder head high performance type, complete, including	1
	Cylinder head proper	1
2381	Compression relief valve complete, including	1
2382	Compression relief valve proper	1
2383	Spring - compression relief valve	1
2384	Plug - compression relief valve spring bracket	1
2385	Clip - compression relief valve spring	1
2386	Cotter pin: 2 × 20	1

Reference Number	DESCRIPTION	Quantity per unit
ENGINE UNIT (continued)		
1210	Spark plug «FLOQUET» 14 D 2	1
1211	or «MARCHAL CR 36»	1
1220	or «A.C. - F. 10»	1
255	Nut - cylinder head	4
256	Washer - plain: 6,25 × 14 × 1	4
2153	Intake pipe	1
182	Gasket - intake pipe	1
506	Hex. nut: 5 mm. dia (2 for intake - 4 for exhaust)	6
507	Spring lock-washer - 5 mm dia (internally splined)	6
2503	Insulating sleeve - carburettor	1
189	Gasket - exhaust	1
2638	«GURTNER» D.12.D. Carburettor	1
2706	«GURTNER» D.12.G. Carburettor	1
2521	AUTOMATIC CLUTCH complete, including	1
2519	Driving plate assembly, including	1
2518	Driving plate complete, including	1
	Driving plate proper (1)	1
	Driving hub	1
	Locking plate	1
	Spindle - clutch shoe	2
	Washer - plain: 6,2 × 10,2 × 0,8	2
	Spigot - Spring attachment	2
2288	Ring - snap	1
2517	Inertia ring	1
2506	Clutch shoe complete including each:	2
	Clutch shoe proper	1
	Lining	1
	Rubber insert	1
2360	Locking ring-shoe	2
(1) 2507	Spring-shoe	2
2516	Primary drive pulley complete, including	1
	Riveted pulley, including	1
	Hub - pulley	1
	Race - clutch needle	1
	Flange-outer	1
	Driver-free wheel	1
	Rivet-flat head: 3 mm. dia	3
2504	Sleeve - needle	2
2357	Inner race-free wheel	1
2358	Needle: 4 mm dia. × 6 mm long	3
2368	Washer-stop	1
2369	Cup-grease retaining	1
2505	Washer-grease retainer	1
2510	Washer-thrust	1
2512	Washer-lock	1
2513	Screw - thrust	1
	For fastening of the automatic clutch on the crankshaft	
2391	SECONDARY DRIVE complete including	1
	Secondary pulley proper	1
2334	«Nadella» bushing	2
	Spigot-stop	1
	Spring-stop	1
2399	Washer - friction	1
2400	Coupling plate	1
2402	Washer - gasket	1
2403	Plate-fixing	1

(1) Bears also Nr. 2372 in the early VAP 55 engines

Reference Number	DESCRIPTION	Quantity per unit
SECONDARY DRIVE complete (Continued)		
2393	Sliding Blocks complete, including each	2
	Sliding member, proper	1
	Spigot-operating	1
2395	Spring - return	4
2396	Plate - protective	1
2397	Screw-cheese head: 4 mm. dia × 8 mm. long	4
2398	Washer - spring lock: 4 mm. dia	4
2394	Chain sprocket complete, including	1
	Sprocket, proper	1
	Cup - protective	1
2346	Washer-Bearing: 2 mm thick	1
2338	Washer-thrust, pedal side: 1 mm thick	2
2337	« V » belt	1
2259	Spindle-pedal crank	1
2264	Nipple-pedal crank spindle lubrication	1
2235	Fixed cup-pedal crank	1
2236	Adjustable cup-pedal crank	1
2237	Lock-nut	1
2238	Lockwasher: 0,8 mm thick	1
ENGINE MOUNTING COMPONENTS ON THE CYCLE MOTOR FRAMEWORK (2)		
2378	Ferrule for the front down tube	2
2154	Ferrule for the crank wheel bushing - right hand	1
2255	Ferrule for the crank wheel bushing - left hand	1
Upper assembly components:		
2379	Screw-Hex. head: 8 mm dia. × 30 mm long	1
2284	Washer - Grower: 8 mm dia.	1
1172	Nut - Hex.: 8 mm dia.	1
Lower assembly components:		
2233	Screw - Hex. head: 8 mm dia. × 65 mm long	1
1172	Nut - Hex.: 8 mm dia.	1
	Lock nut - 8 mm dia.	2
2273	Washer: plain: 8,25 × 18 × 2	1
2258	Tubular spacer lower ferrule	1
2271	SILENCER AND EXHAUST PIPE, including:	
2274	Silencer complete, including	1
	Silencer, proper	1
	Cup-silencer	1
	Stud-fixing	1
	Solder lug	1
2275	Silencer cover, including	1
	Tube-silencer cover	1
	Silencer cover, proper	1
	Cup-silencer cover	1
516	Washer-plain: 6,25 × 12 × 1	1
2276	Cap nut-Hex.: 6 mm dia.	1
2277	Flanged pipe, including	1
	Pipe, proper	1
2278	Flange	1
VAP 57 Engine greased at the factory		

(2) The A.B.G. genuine engine mounting ferrules, together with the silencer are not standard equipments for all Types of cyclemotors.



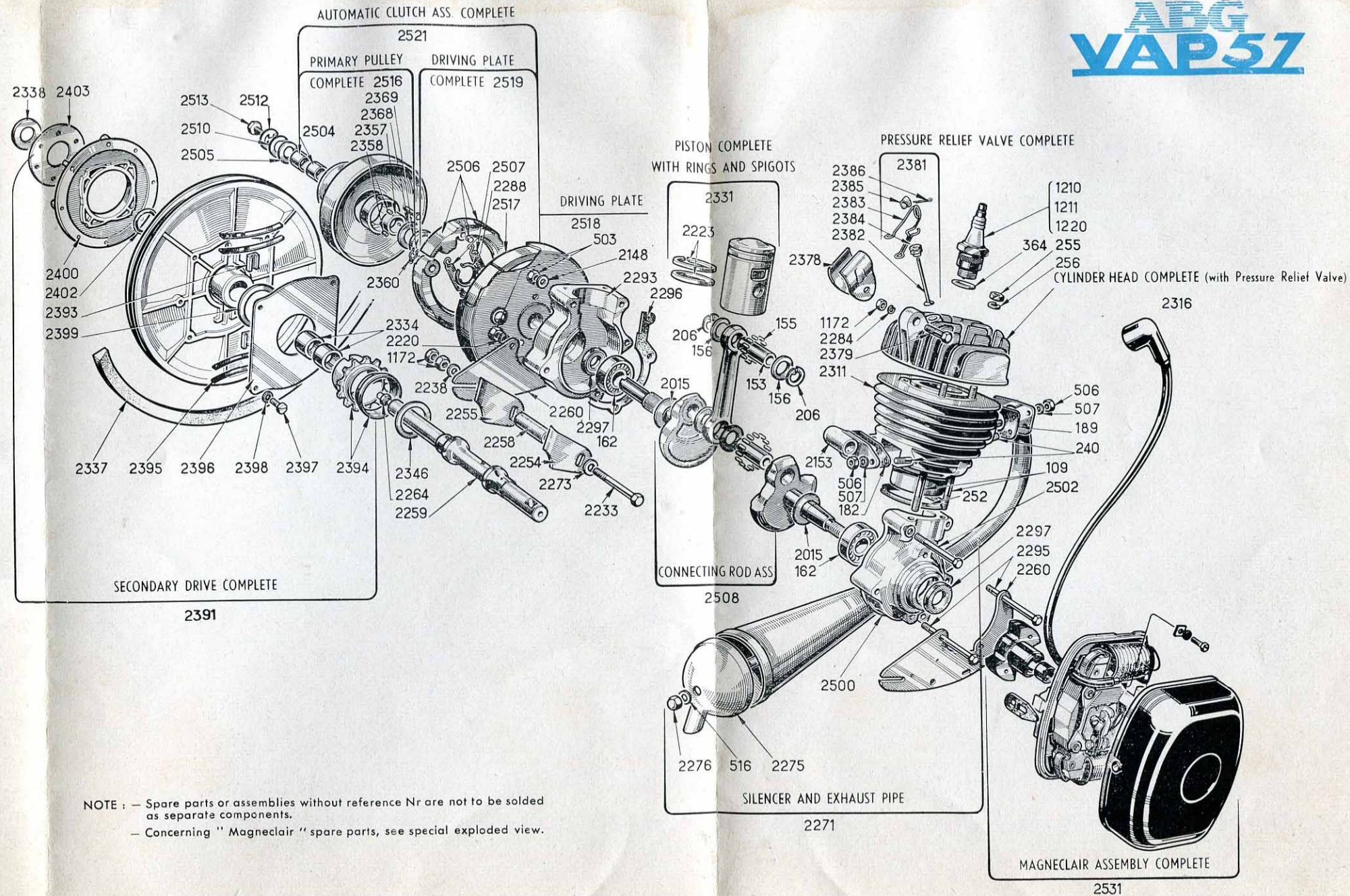

ABG

Société Anonyme au Capital de 450 millions

3, Impasse Thoreton - PARIS-15^e

(France)

Télégramme : LABÉGÉ-PARIS

Téléphone : VAUgirard : 68-40

IceniCAM Information Service

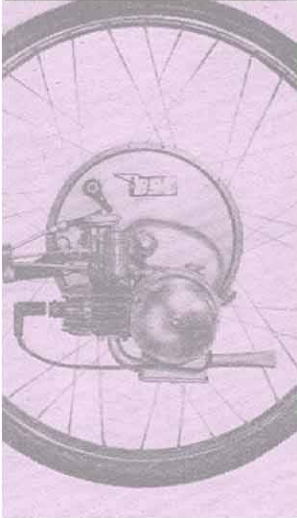

www.icenicam.org.uk