

# IceniCAM Information Service

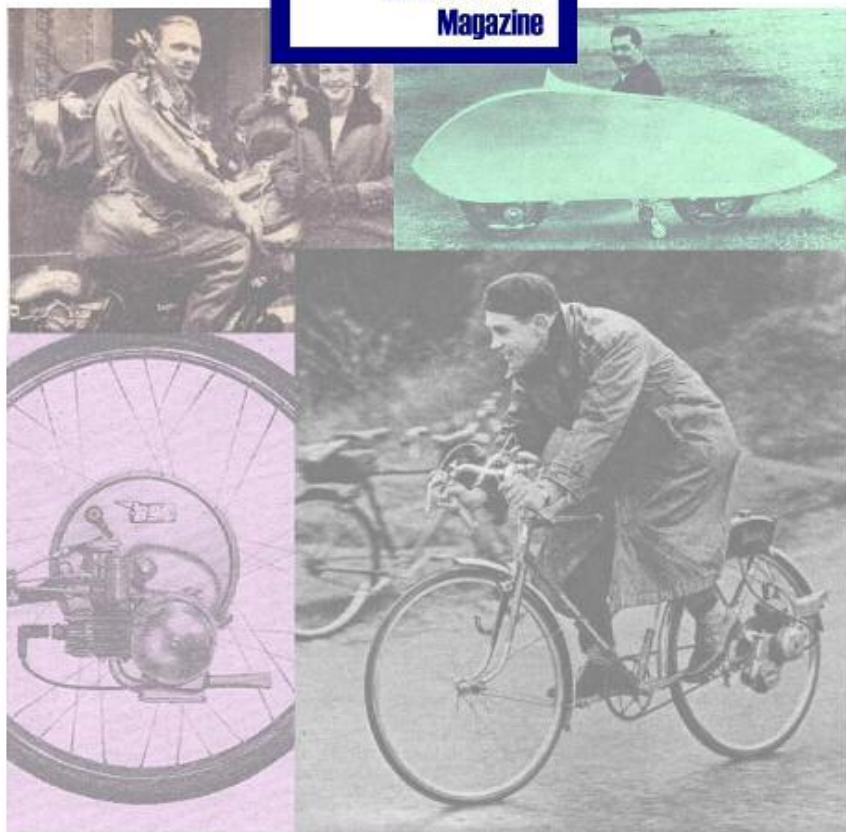

[www.icenicam.org.uk](http://www.icenicam.org.uk)

F&S

# SACHS 50/2

Two-speed Model

# REPAIR MANUAL



FICHEL & SACHS AG · SCHWEINFURT/MAIN

# **SACHS 50/2**

**Two-speed Model**

## **REPAIR MANUAL**



**FICHEL & SACHS AG · SCHWEINFURT/MAIN**

# CONTENTS

Preface . . . . .	3
Technical Data . . . . .	4
1. Repair Tools . . . . .	5
2. Special Tools . . . . .	6
3. The F. & S. Work Jig . . . . .	7
4. Taking the engine down . . . . .	8
5. Working on individual parts . . . . .	17
6. Assembling the engine . . . . .	22
7. Fitting the engine into the frame . . . . .	30
8. The "SACHS 50" with kick-starter . . . . .	32

## PREFACE

The blue shield with the large "S", or a shield with "SACHS-Moped-Service" is a sign to show every SACHS rider a place where he can confidently take his machine in case of breakdown, or if natural wear and tear should call for renewal of one or the other part of the engine. These shields guarantee the rider finding competent repairmen there with an intimate knowledge of his engine down to the last detail, as well as a place where he will not have to wait very long for replacement parts.

Not every mechanic or apprentice has been trained in our Schweinfurt Works, however, though they should be fully competent to help riders of SACHS machines, especially in carrying out work of a simpler nature, and that is the reason why we have brought out this Repair Manual for the SACHS 50 machine.

The Manual gives a full and complete description of dismantling and assembling the machine. Needless to say, a good many things that happen on the road call only for work on parts of the engine accessible without taking it down completely - in most cases the engine need not be removed from the frame. Quite simple tasks, such as taking down the carburetter, are no longer described in the Manual, the Handbook already containing full information.

The description is of the two-speed SACHS 50 engine/gear unit; the SACHS 50 two-speed fan-cooled model is basically the same as the SACHS 50 engine in design, except for the two-part fan casing replacing the left-hand side cover of the housing and the fan being bolted on to the magneto flywheel.

## TECHNICAL DATA

Cylinder bore:	1.496 in. (38 mm)
Piston stroke:	1.654 in. (42 mm)
Cubic capacity:	47 c. c.
Compression ratio:	6 to 1
Ignition system:	Bosch flywheel magneto and lighting generator
Lighting output:	6 volts 17 watts A .C.
Sparking plug:	Bosch W. 190 M 11 S
Ignition advance:	2 - 2½ mm before t. d. c.
Carburetter:	"Bing"; main jet 56, needle jet 2.10, needle setting, 3rd notch from top; gas slide (throttle) 3
Silencer:	AB 1092, demountable
Clutch:	Two-plate disc clutch
Gear:	Two-speed gear in engine block
Gear change:	By handlebar twist grip
Ratios in gearbox:	First gear, 2.78 Second gear, 1.77
Transmission:	½" x ⅜" roller chain to rear wheel; rollers 7.8 mm diameter
Driving chain sprocket:	12 teeth for 23" tyres
Rear wheel chain wheel:	28 teeth for 23" tyres
Total transmission ratios:	First gear, 24.5 to 1 Second gear, 15.6 to 1
Lubrication system:	Engine, petrol mixture, 1 in 25 Gearbox, 200 c. c. of SAE 80 gear oil

# 1. REPAIR TOOLS

KAS 310-48

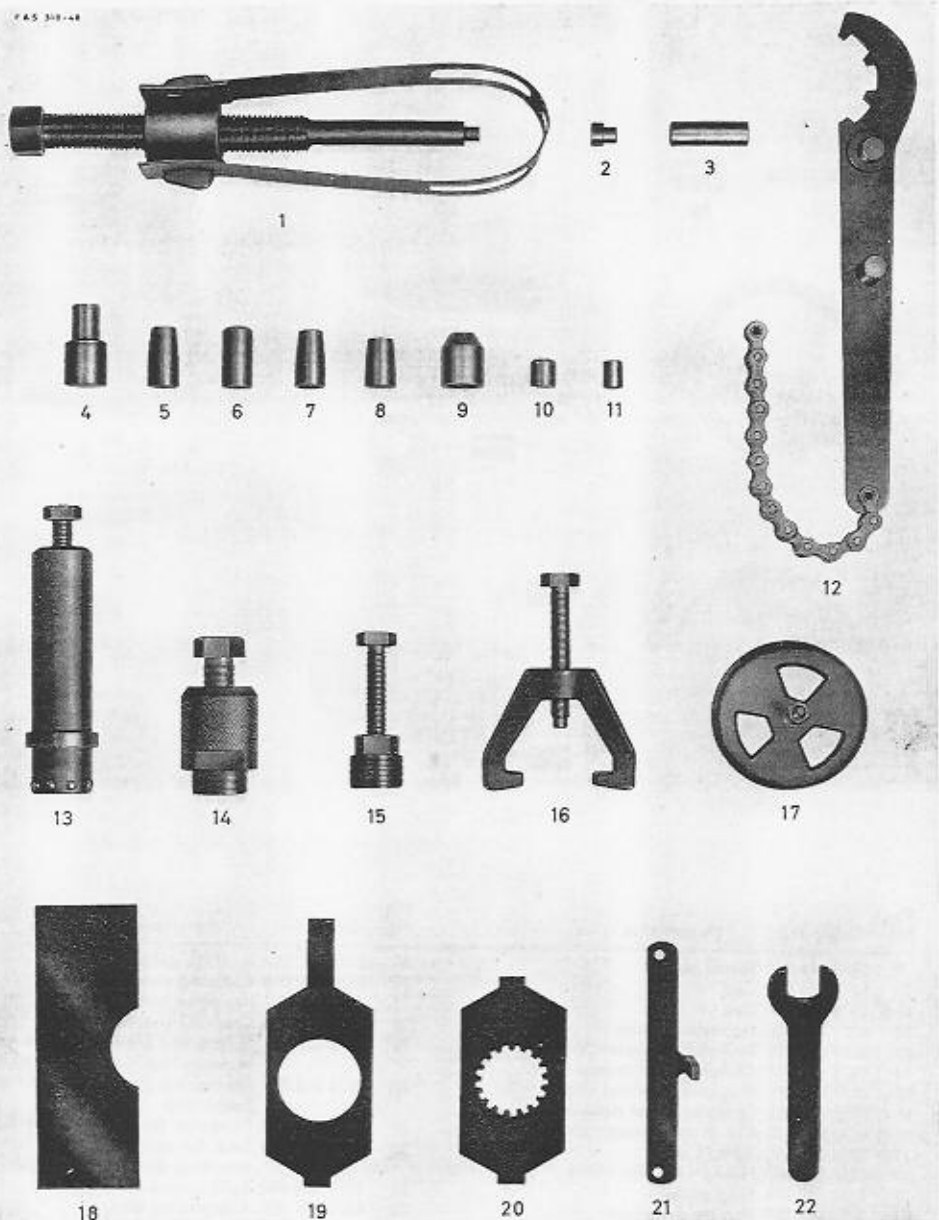

Fig. No.	Order No.	Description	Fig. No.	Order No.	Description
	0277 079 006	Toolkit, complete	5	0277 077 000	Crankshaft sleeve (magneto side)
1	0276 065 001	Gudgeon pin extractor	6	0277 072 000	Cap, 10.2 diameter
2	0277 083 000	Insert bush for gudgeon pin extractor	7	0277 078 000	Crankshaft sleeve, clutch side
3	0276 023 001	Fixing pin.	8	0278 022 000	Crankshaft sleeve, clutch side
4	0676 022 005	Guide pin			

## 2. SPECIAL TOOLS

Fig. 310-48

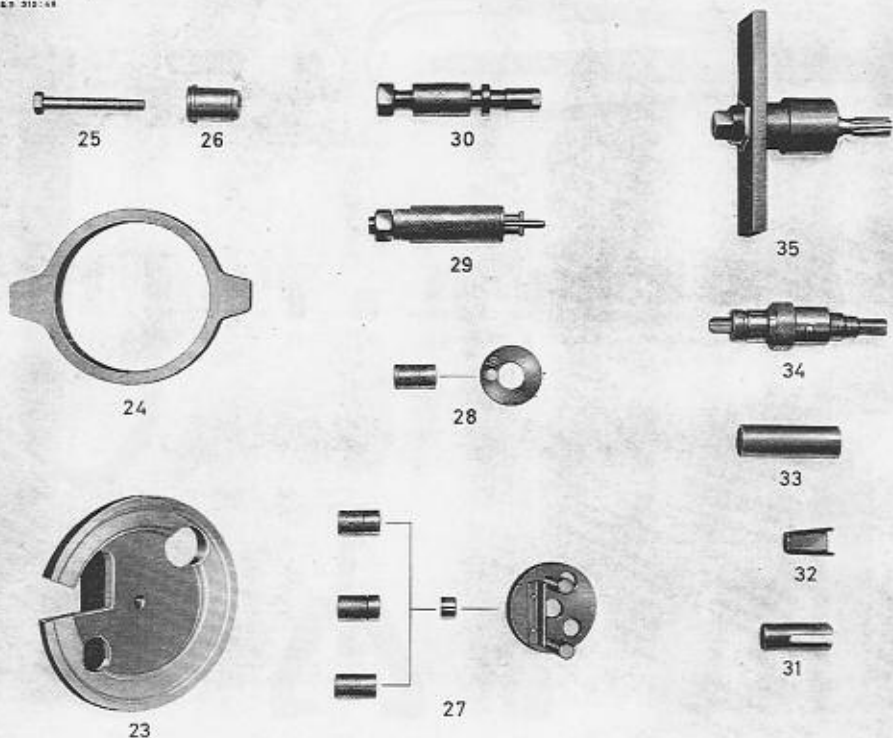

Fig. No.	Order No.	Description	Fig. No.	Order No.	Description
9	0276 046 000	Thrust bush	23	0277 000 001	Ignition centring plate
10	0277 070 000	Cap	24	0277 080 000	Centring ring
11	0278 023 000	Cap	25	0241 017 000	Hexagon bolt
12	0277 086 006	Hooked spanner	26	0277 082 000	Centring piece
13	0277 073 005	Ball-bearing extractor	27	0277 026 000	Measuring plate complete with three milled nuts
14	0676 011 001	Clutch centre drawer	28	0278 018 000	Measuring plate for mainshaft, Sachs 50/3
15	0277 075 005	Magneto flywheel drawer	29	0277 014 000	Extractor for countershaft bush
16	0277 076 005	Chain sprocket drawdog	30	0277 008 000	Tool for extracting and inserting gudgeon pin bush
17	0276 057 000	Clutch compressor plate	31	0277 088 000	Split sleeve
18	0276 019 001	Spacer plate	32	0277 087 000	Assembling sleeve
19	0278 008 000	Fixing plate for clutch	33	0277 089 000	Extension piece
20	0292 022 000	Stop plate	34	0277 013 001	Jig for setting ignition advance
21	0278 007 000	Fan holder plate	35	0277 066 000	Reamering device, complete, for countershaft bearing bush
22	0278 024 000	Spanner, 17 mm, for operating pin			
	0297 004 000	Board to take set of tools (supplied to special order only and charged for separately)			



### 3. THE F&S WORK JIG

A work jig has been devised for carrying out all work on Sachs engine units safely and conveniently; it is held in a vice and enables all Sachs engine units to be taken down and re-assembled.

Fig. 1

The basic model illustrated - No. 0276 080 000 - is held in a vice by a special clamp **s**; as the device swivels and tips as well **d**, **k**, work can be carried out quickly and in full view. A retaining strap and chain **h** that can be attached to the device enables the nuts to be removed from the magneto flywheel and chain sprocket quite easily. The basic form of work jig has been brought out for the Sachs 100/two-speed unit.

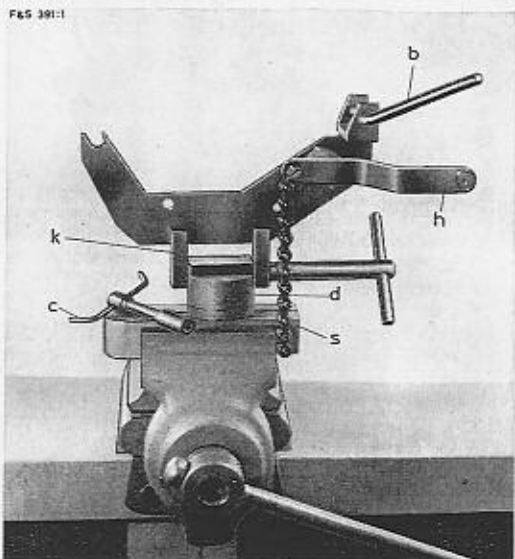

Fig. 1

Fig. 2

An assembly lug **m** - No. 0277 084 000 - with a second fixing pin and metric 8 flynut, and a bolt **n**, metric 6 x 20, with nut, is attached to the basic model No. 0276 080 000 for working on the Sachs 50 unit.

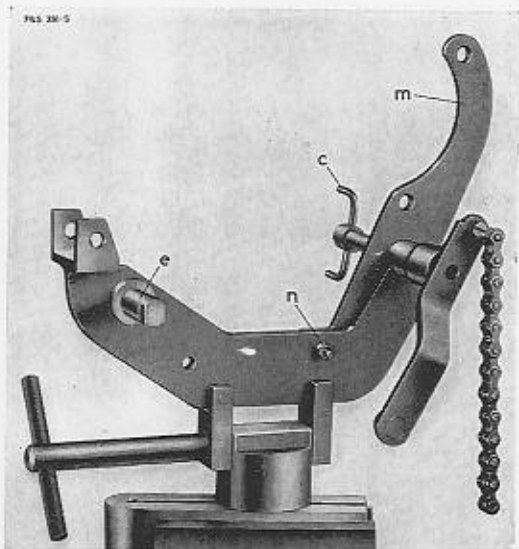

Fig. 2

## 4. TAKING THE ENGINE DOWN

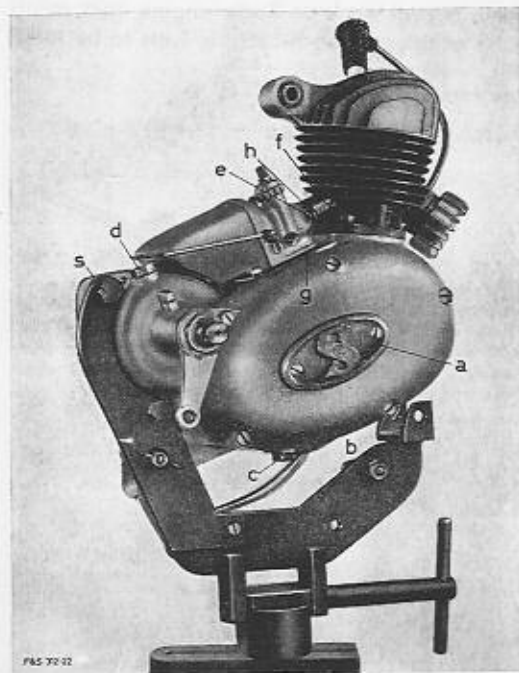

Fig. 3



Fig. 4

After removal from the frame, thoroughly clean off all dirt on the outside of the engine.

Fig. 3

Next, take off the cover with the "S" on it **a** from the clutch side of the unit, taking out the two filisterheaded screws by a screwdriver. Then unscrew and remove the oil filler and drain plugs **d** and **b**, together with the plug for checking the oil level **c**, using a 14 mm spanner. Lay the engine on its side, and let the whole of the oil drain out.

Bolt the engine unit on to the F. & S. work jig No. 0276 080 005, using two metric 8 x 50 bolts and nuts **s**, and tightening by a 14 mm spanner.

Unscrew carburetter – two fixing nuts metric 5 **e**, with special "Novotex-steel" washers **h**, using a 9 mm spanner. Remove the carburetter flange washer **f** – asbestos – and also the rubber or cork packing-cemented **g** on to the housing.

Fig. 4

### Housing cover, magneto side (SACHS).

Unscrew cover – two screws metric 6 x 35 – by a screwdriver.

For the speedometer drive **k** in the magneto side housing cover see the section on "Working on individual parts".

Fig. 5

### Driving sprocket

Fix the retaining strap and chain **m** on to the right-hand holding pin **q** of the F. & S. work jig and lay the chain from right to left over the sprocket.

Unscrew the metric 10 nut – where the speedometer drive is in the cover – special metric 8 nut **p** (with slot), and remove the spring washer. (14' or 17 mm spanner). Remove the retaining strap and chain.

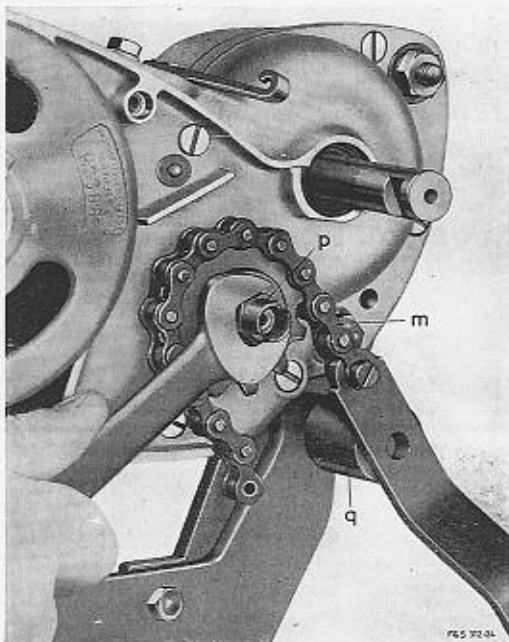

Fig. 5

Fig. 6

Fit cap **s** – No. 0277 070 000 with fibre insert – on the mainshaft to protect the thread and draw off the chain sprocket using drawdog **r** – No. 0277 076 005 – (for 13 teeth and over use drawdog No. 0276 011 005), by a 17 mm spanner. Remove Woodruff key from mainshaft by a pair of side-cutting pliers.

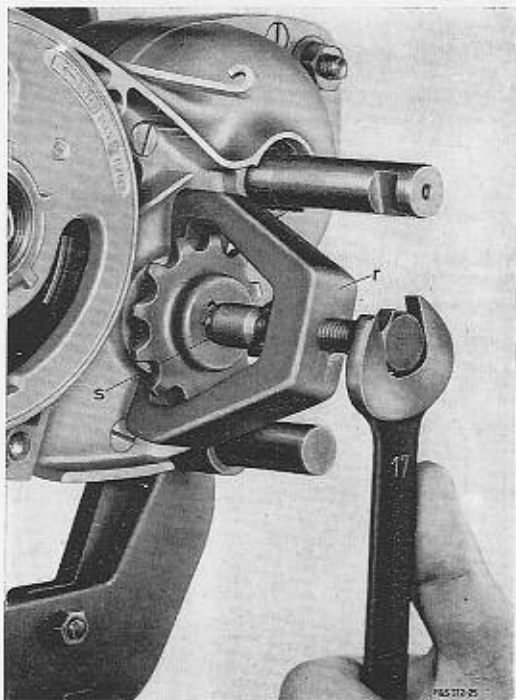

Fig. 6

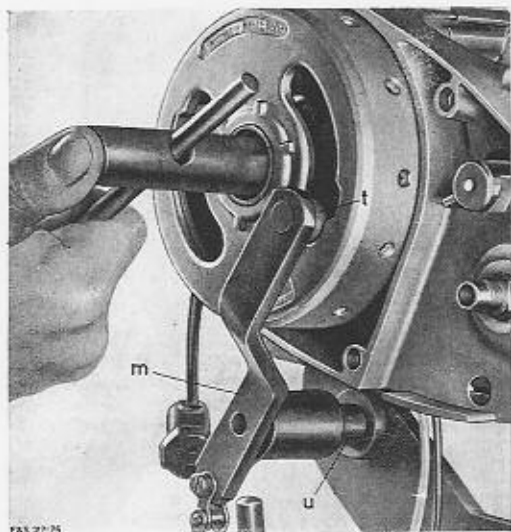

Fig. 7

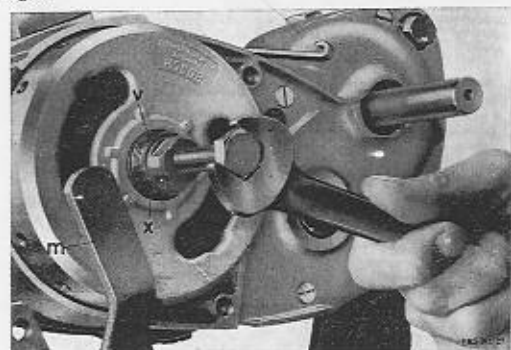

Fig. 8

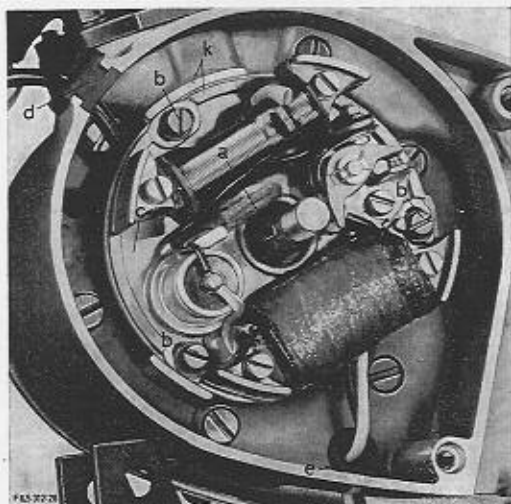

Fig. 9

Fig. 7

### Ignition system

Fix the retaining strap **m** on the left-hand holding pin **u** of the work jig and fit the pin **t** of the strap into one of the slots of the flywheel magneto so that the strap is in tension when unscrewing the fixing nut (collar nut) by a 14 mm box spanner. The Woodruff key can easily be removed by tipping the engine unit cover.

Fig. 8

To draw off the flywheel magneto fit cap **v**—No. 0277 070 000—on the crankshaft, screw in drawing tool **x**—No. 0277 075 005—and reset the retaining strap **m** so that it is again in tension when drawing off (17 mm spanner).

Fig. 9

Leave the Woodruff key **a** in the crankshaft, as there is risk of damage to the armature if it is taken out too soon. Take out armature backplate **c** by unscrewing three screws **b** with their plain and spring washers, by a screwdriver. Carefully press the rubber grommets **d**, **e** for the ignition, lighting and short-circuiting cables out of the armature backplate **c** before taking the latter out of the housing. The armature backplate when taken out should be put together with the flywheel magneto (i. e., short-circuited). Remove Woodruff key **a** from the crankshaft by a pair of side-cutting pliers.

Fig. 10

Unscrew cylinder head (with or without decompressor) – four metric 6 cylinder head screws with washers – using a 10 mm box spanner. There is no gasket. A defective decompressor can only be replaced by a complete decompressor assembly.

Unscrew cylinder – four metric 6 nuts with spring washers – using a 10 mm ring or open spanner. Draw cylinder off upwards without turning it; remove cylinder flange washer (f).

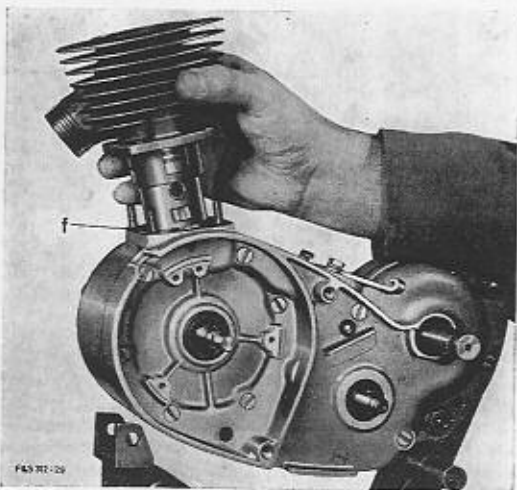

Fig. 10

Fig. 11

#### Piston and gudgeon pin

Place a wooden block with a slot in it **a** between the housing (crankcase) and piston (closing the crankcase opening with a cloth if necessary). Remove gudgeon pin retaining circlips **b** by round-nosed pliers.



Fig. 11

Fig. 12

Press out the gudgeon pin using the insert bush **d** – No. 0277 083 000 – and gudgeon pin extractor **e**. Be careful of the piston rings, as there is the risk of breaking them. Take away the slotted wooden block.

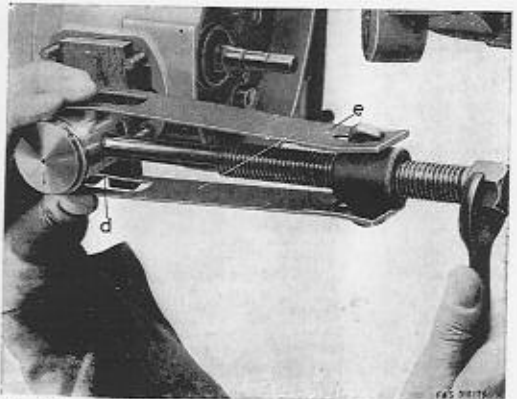

Fig. 12



Fig. 13

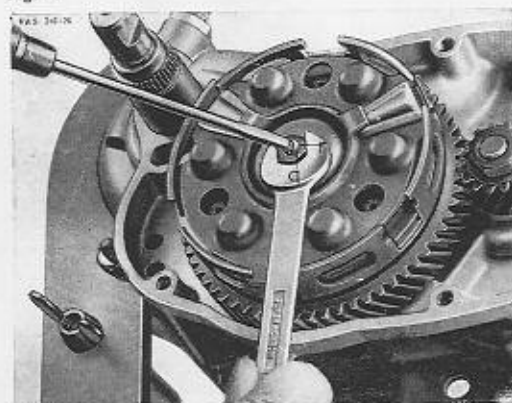

Fig. 14

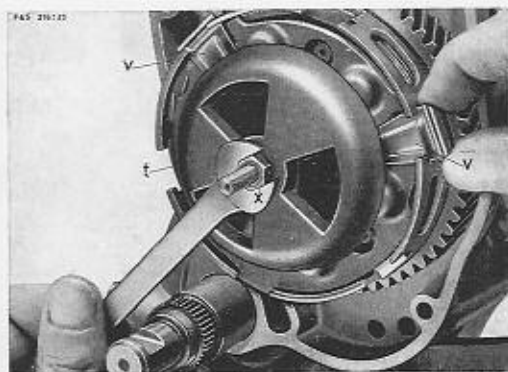

Fig. 15

Fig. 13

### Brake lever and driving side housing cover

Remove circlip *s* by special circlip pliers with the stop set to the correct opening *p*. Remove shims thread and unscrew (26 mm box spanner). Remove locking washer *m*. Release nut *n*, 20.8 L. H. metric *k*. Draw off brake lever and shims *h* from the ground flange serrated disc washer *g*. Lift off of the driving bush. Unscrew housing cover on driving side – five metric 6 x 35 screws – by a screwdriver. Remove the "Abil" packing.

Fig. 14

Slacken locknut *r* of the adjusting screw *q* for the clutch and unscrew adjusting screw with its nut, using a screwdriver and 11 mm spanner.

Fig. 15

### Clutch

Screw clutch compressor plate *t* – No. 0276 057 000 – into the metric 6 thread of the thrust plate. Compress the spring plate with the six thrust springs and the thrust plate by the metric 6 nut of the compressor sufficiently (10 mm spanner) for the two locking plates to be taken out easily. Lift out the compressed spring unit together with the compressor plate. Slacken the nut of the compressor plate three to four turns until reassembling so as to avoid fatigue of the thrust springs in the compressed spring assembly. Take out the



clutch plates (lined plate, steel plate, lined plate) and remove the clutch pin – two thrust pins and one intermediate roller – by tilting the engine unit over.

Fig. 16

Place the clutch fixing plate **a** – No. 0278 008 000 – and the stop plate **b** – No. 0292 022 000 – in the clutch housing. Unscrew the metric 12 nut on the clutch centre and take out the spring washer (17 mm box spanner).

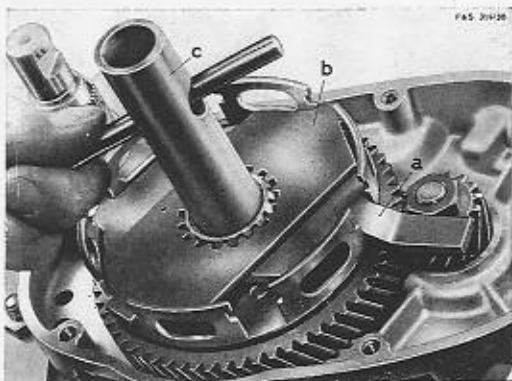

Fig. 16

Fig. 17

Screw the drawing tool **d** – No. 0677 011 001 – **without** any cap, into the clutch centre and draw out (22 mm spanner). Remove stop plate **b** but leave fixing plate in position.

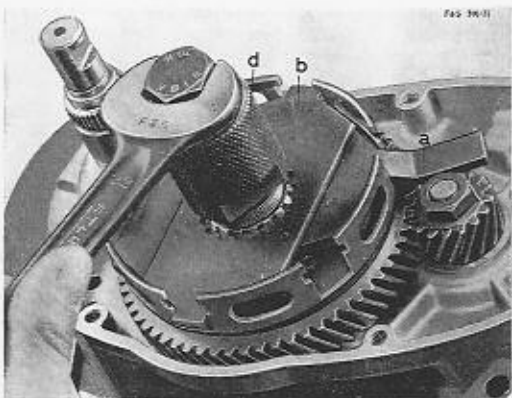

Fig. 17

Fig. 18

Remove Woodruff key **p** from countershaft (sidecutting pliers). Release nut **n**, 20.8 metric L. H. thread, and unscrew by 26 mm box spanner. Take out locking plate **m**. Release nut **h**, 10 metric R. H. thread on crankshaft, and unscrew (17 mm spanner). Take off locking washer **k**. (On chain-driven models the nut is metric 8 R. H. thread – use a 14 mm spanner). Remove fixing plate **a** – (fig. 17).

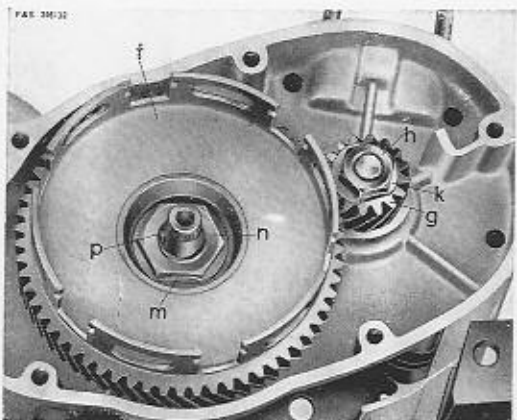

Fig. 18

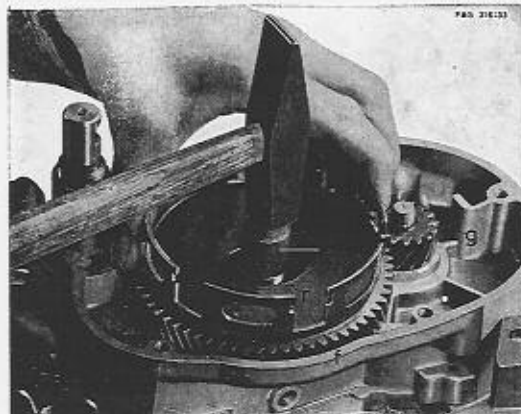

Fig. 19

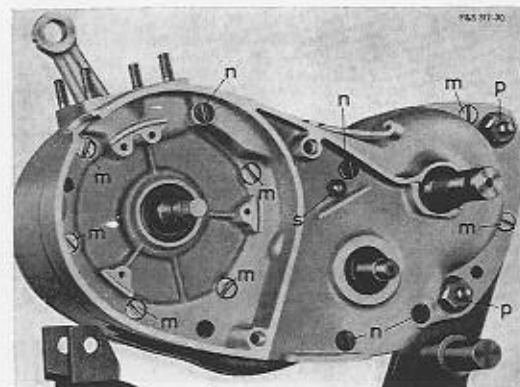

Fig. 20

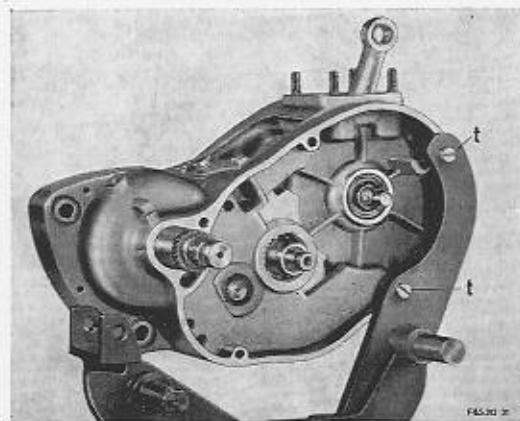

Fig. 21

Fig. 19

Place the thrust bush **q** – No. 0276 046 000 – on the ball race bush **r** (Countershaft) – Do not use any sleeve on the crankshaft. Taking the weight of the clutch housing **f** by one hand, tap the thrust bush sharply with an 8-oz. hammer at the same time, so that the clutch housing and driving gear (**g**) will come out of the casing together. (On the chain-driven model, after tapping the bush, the clutch housing and main drive sprocket can be taken out together with the chain connecting them). Take the Woodruff key out of the crankshaft by a pair of side-cutting pliers.

There are no shims, none being necessary. (On the other hand, on chain-driven models, there may be shims on the crankshaft and they should be removed after the key has been taken out – see "Assembling the engine".

Fig. 20

#### Gear and crankshaft.

Unscrew seven metric 6 x 20 screws **m** and four screws metric 6 x 35 **n** on the magneto side, using a screwdriver. Unbolt the engine/gear unit from the F. & S. work jig – 14 mm spanner **p**.

Fig. 21

Bolt the engine/gear unit back on to the work jig again, with the cover face against the jig, by two metric 6 x 20 screws **t**, using a screwdriver. Tapping the mainshaft, crankshaft and pedal spindle lightly with a rubber hammer will separate the two halves of the housing.



Fig. 22

Pressing the palm of the left hand on the pedal spindle **a**, the left thumb on the mainshaft **b** and the right thumb on the crankshaft **c** allows the magneto side half-casing to be drawn off by the finger tips of both hands.

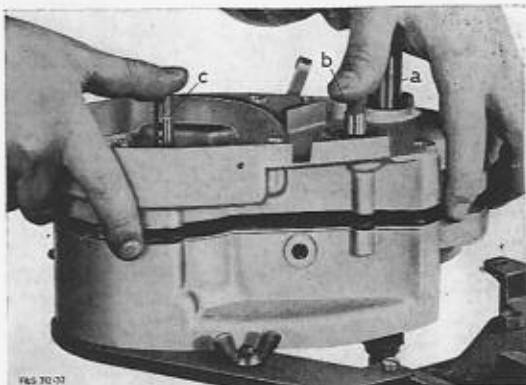

Fig. 22

Fig. 23

Watch the two fixing plates **d** for the rubber bushings and any shims that may be stuck on to the main and countershafts. Take out the crankshaft **e**—which can be done in any position. (But reassemble only with the crankshaft sleeve No. 0278 022 000 — on chain-driven models, sleeve No. 0277 078 000).

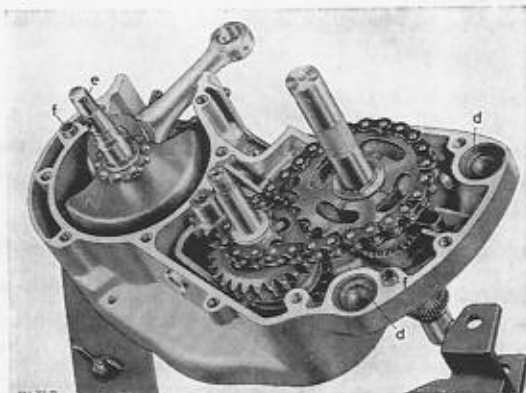

Fig. 23

Fig. 24

With both hands, take out together pedal spindle **g** with chain wheel **h** fixed by circlip **k**, driver **m** with check spring **p**, on the one side, and also the 9-tooth sprocket on the mainshaft with its chain, on the other side. Mind the thrust washer under the driving bush and the shims **r** on the 9-tooth sprocket lifted off from the mainshaft and on the countershaft. Lift off the large change-gear wheel (first speed) and take out mainshaft **q**.

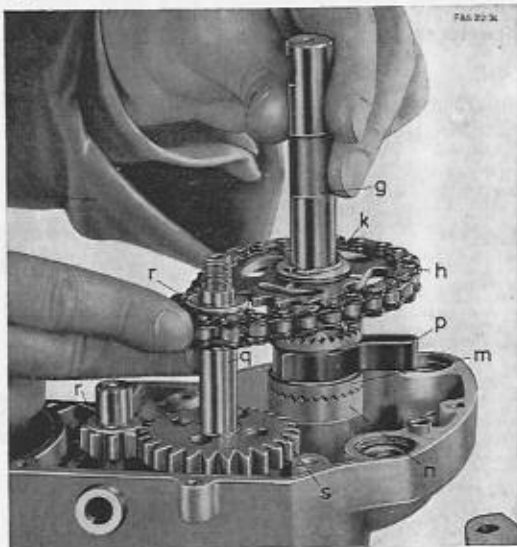

Fig. 24

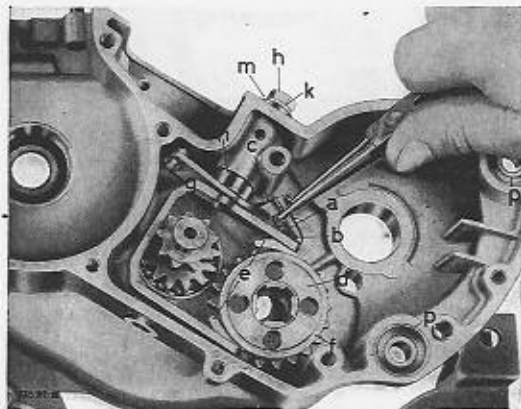

Fig. 25

Fig. 25

Unclip tension spring **a** with spring pin **b** on the striker fork **c**, using round-nosed pliers, and remove from the housing. Take out, one after the other, striker plate **d** with the two slippers **e** – their centre of gravity towards the countershaft, the small gear wheel **f** – 23 or 21 teeth, second speed, and also the thrust washer (2 mm) under the small gear wheel. Take out countershaft **g** with its thrust washer (formerly star disc) and the bearing race bush with the rotating bronze sleeve. Screw out the metric 6 hexagon bolt **h** with spring washer **k** for the gear-change

lever, using a 10 mm spanner, and take away the striking fork **c** with its collar **n**, also withdraw the gear-change lever **m** with its spring washer. Watch the buna gasket with its protector cap.

Unscrew the clutch side half-housing from the F. & S. work jig, using a screwdriver.

Take out and check the bearing rollers from the two halves of the housing. If necessary, remove the clutch lever stop (slotted pin) – **s** in fig. 20 in the magneto side half-housing, using a pair of side-cutting pliers, and withdraw the clutch lever.

Renew the buna gasket with its protector cap, if damaged.

Clean all parts of housing and gear, inspect all parts, and replace or renew as necessary.

**ALWAYS USE GENUINE "SACHS" PARTS.**



## 5. WORKING ON INDIVIDUAL PARTS

### Changing the roller bearing and single-thrust outer races in both halves of the housing.

Press the rubber bushings **a** out of both halves of the housing, if not already done, before warming up the housing. Warm up the halves of the housing to 60 to 70° (be careful with welding torches – the housing is made of die-cast electron) and remove the outer races by tapping lightly with a rubber hammer.

It is an advantage to have new races at hand before warming up the halves of the housing, so that they can be pressed in with the housing at the same temperature; this saves repeating warming up.

**Do not change single-thrust bearings from one side to the other.**

After cooling down, all outer races, especially those for the single-thrust bearings, must be pressed in again on account of the seating.

Fig. 26

### Initial assembly of magneto side half-housing.

#### Crankshaft bearing.

Press in, one after the other, the buna (artificial rubber) washer **b**, with the rubber lip towards the crank web, and the single-thrust bearing outer race **c** E. 15.

#### Mainshaft bearing.

Press in the buna washer (old type, with the rubber lip towards the inner side of the housing; new type, with the spring of the washer to the outside – coat with grease), the intermediate retaining washer and the roller bearing outer race **d** together; for the 15.5-mm diameter shaft, insert 15 rollers 4 x 8 mm; for the 13-mm diameter shaft, 13 rollers 4 x 8 mm; place in position with high melting-point grease and cover with the intermediate retaining washer **e**.

#### Countershaft bearing.

The bronze bush **g** No. 0233 002 005 is a component of the half-housing; should the bush be defective, it can be extracted by the special extractor No. 0277 014 000.

### Using the special extractor, No. 0277 014 000.

Take the special extractor apart and, overcoming the gripping force with the grippers, insert the jaws **f** into the bronze bush. Drive in pin **h** up to the stop in the jaws to expand the two grippers, then extract the bronze bush by the thrust sleeve **k** and nut **m**.

Press the new replacement bush No. 0233 002 009 into the housing.

**Caution:** The oil lubricating groove in the bronze bush must be brought into line with the oil hole in the housing. Drill an oil lubricating hole 4 mm diameter in the bronze bushing through from the housing and then reamer out the bronze bush with the special reaming tool No. 0277 066 000.

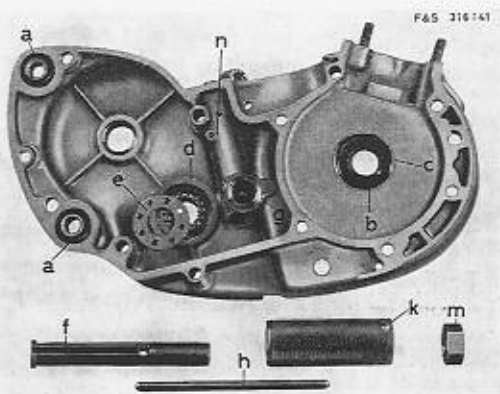

Fig. 26

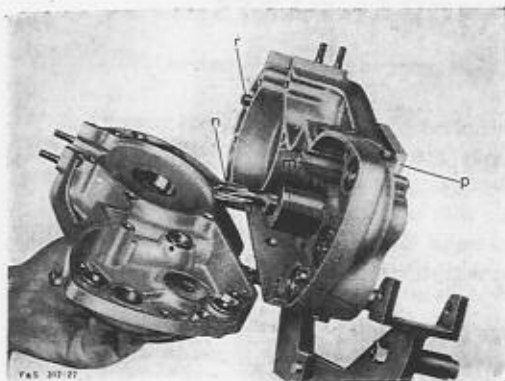

Fig. 27

together, using the two dowel pins *r* as guides, by three metric 6 screws, and the bronze bush reamed out by the finishing reamer *n*.

#### Pedal spindle bearing

The bronze bush No. 0232 039 000 with buna packing washer No. 0250 084 000 (rubber lip towards the bronze bush) is a component of the half-housing.

#### Clutch lever bearing

Place the buna packing washer No. 0650 017 00 and protector cap No. 0246 012 000 in position together (rubber lip towards the housing). Then oil and insert the clutch lever and fix by slotted pin with rubber washer.

#### Engine unit suspension

Press in by a hand press the two rubber bearings No. 0260 021 000 for the engine unit suspension, remembering that the thicker part of the wall of the steel bush is towards the outside of the housing as the abutment in the frame. Pressing in the rubber bushes applies similarly to both halves of the housing and to the cylinder head.

Fig. 28 (continued)

#### Initial assembly of the clutch side half-housing.

**Crankshaft bearing:** See magneto side.

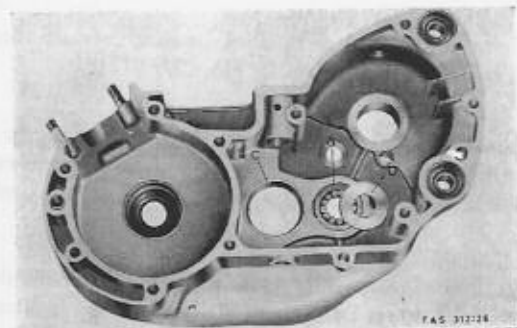

Fig. 28

Fig. 27

#### Using the special reaming tool No. 0277 066 000.

The ball-bearing outer race for the ball-race bushing must be taken out of the clutch side half-housing (heated up to 60 to 70° for the purpose) to use the reaming tool.

The guide bush *m* for the reamer *n* is then placed into this bearing seating and tightened by the fixing plate and metric 24 nut (L. H. thread). The two halves of the housing can then be screwed

#### Mainshaft bearing

Place retaining washer No. 0244 078 000 in position and press in the outer race *a* No. 0232 049 000. Then insert 15 rollers No. 0232 002 000 (4 x 6 mm) with high melting-point grease and cover with retaining washer *b* No. 0244 078 000.

#### Countershaft bearing

Press in the single-thrust bearing outer race E. 15 *c* for the ball race bush.

Fig. 29

### Crankshaft

Crankshafts repaired by outside concerns or those that have been ground, welded or brazed cannot be exchanged.

#### Measuring up the halves of the housing (crankcase) for fitting the crankshaft.

Place the "Abil" gasket in place on the housing. Crankshaft end play must be 0.05 to 0.15 mm.

#### Example

Measurement of clutch side half-housing plus gasket:	26.30 mm
Measurement of magneto-side half-housing:	+ 6.10 mm
Space in housing:	32.40 mm
Crankshaft measurement (electrically recorded):	- 30.10 mm
	2.30 mm
End play:	- 0.10 mm
Difference:	2.20 mm

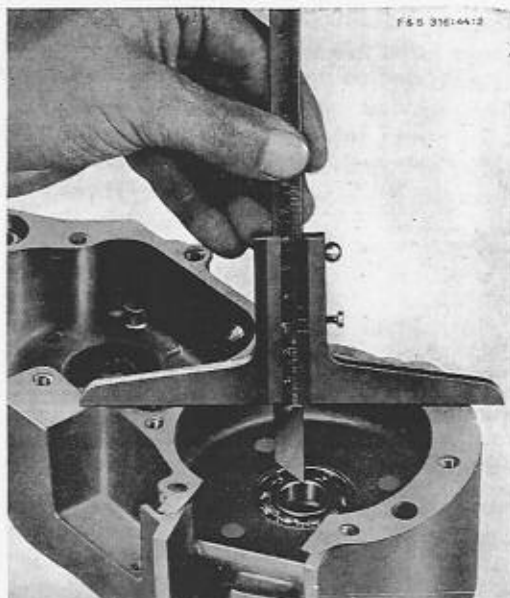

Fig. 29

Fig. 30

This difference of 2.20 mm is made up evenly on either side of the crankshaft behind the ball-bearing inner races **e**, i. e., 1.10 mm each side, by shims **d**.

Always use the spacer plate No. 0276 019 001 in every case when drawing on the inner races; placed between the crank webs, it acts as a support so that the inner races, heated up to 60 to 70°, can be shrunk on very satisfactorily.

**Caution:** Never grip the crankshaft by the crank journals in a vice to drive the inner races on. Such treatment cannot fail to squeeze the crank webs together with the result that the crankshaft is then useless.

#### Changing the single-thrust bearing inner races

Remove the ball cage **f** from the inner ball race **e** on the crankshaft and draw off the inner race with the special ball-bearing extractor No. 0277 073 005 and cap No. 0277 070 000. Draw on the inner race as already stated.

#### Changing the gudgeon pin bush - the "Hunger" special reaming tool.

Withdraw the worn bronze bush by means of the special extracting tool No. 0277 008 000 and draw in the replacement bronze bush No. 0232 038 005 with the same tool. Then reamer out to finished size by the "Hunger" special reaming tool (see F. & S. List No. 308.81).

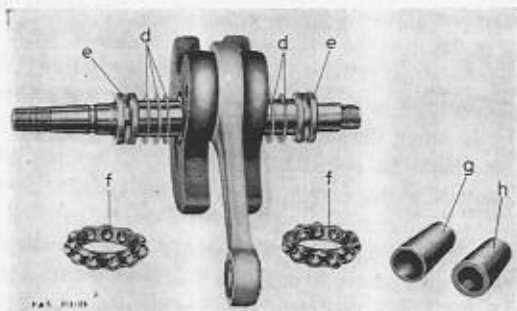

Fig. 30

## Piston and cylinders

Cylinder bores and pistons to fit them are shown by coloured marks in the cylinder inlet ports and on piston crowns (white for oversize, and red for undersize). Thus, a cylinder marked red goes with a piston similarly marked, and a white cylinder with a white piston. This arrangement applies in principle to all SACHS engine cylinders, whether new or exchanged. Cylinders cannot be exchanged if they have more than two cooling fins broken, or if they have been welded or brazed.



Fig. 31

Fig. 31

## Flywheel magneto ignition and lighting unit.

### Repairing the ignition set

Place the armature baseplate in the centering plate No. 0277 000 000 and tighten by means of spacer bush No. 0277 082 000 and hexagon bolt No. 0241 017 000, passing the ignition lighting and contact-breaker cables through the hole in the centering plate. Remove defective ignition and lighting armatures or coils and fit new ones. Place the centering ring No. 0277 080 000 over the assembly and press the newly-fitted coils against the centering ring by the thumb and forefinger, tightening by using cylinder head screws with spring washers and a screw-

driver. The air gap between the armature core and magneto flywheel will be correct after the centering ring has been removed. Clip the ignition cable to the connection on the ignition coil, but do not solder it, taking care not to damage the windings when doing so.

### Changing the condenser

Unsolder the contact breaker and ignition armature cables. Press the defective condenser out from the armature baseplate by a round piece of wood. Packing pressed into the recess must be removed by a triangular scraper and the new condenser must not be fitted before this is done. Carefully repack lightly, then resolder the ignition armature and contact-breaker cables back into place.

### Exchanging the contact-breaker

Unscrew the contact-breaker cable, noting the sequence of the insulation on the contact plate. Remove the contact-breaker lever from the shouldered screw (spring clip), and unscrew the contact plate.

Fit new parts in the reverse order, being careful with the insulation on the contact plate and also making sure that the contact-breaker contacts are accurately opposite one another. Grease the felt pad with high melting point grease (Bosch Ft 1 V 4 special grease).



### Setting the contact-breaker in the centering fitment

The fibre heel on the contact-breaker lever is placed against the spacer bush having the same diameter as the contact-breaker cam in the magneto flywheel. Shifting the contact-breaker contact plate then enables the contact-breaker to be preset to the prescribed opening of 0.35 to 0.45 mm.

Fig. 32

### Carburettor

It is most necessary for the carburettor to be cleaned frequently, all according to the amount of dust in the air drawn in. The carburettor must be removed from the cylinder for cleaning, then the spring clip pressed off the filter housing and the filter insert and baffle plate taken out.

Wash the filter insert thoroughly in petrol, soak in engine oil afterwards and then leave to drip well. The carburettor body must also be well washed out with petrol, the jets and float being taken out for this purpose and the plug on the mixing chamber under the throttle slide unscrewed. Check the jet needle and needle jet for wear. The jet can be cleaned without taking off the carburettor; it is accessible from the outside, and need only be unscrewed and blown through, cleaned and washed out. Do not clean with steel wire on any account. Reassemble the carburettor after all parts have been cleaned. See the "SACHS 50 two-speed Handbook" for the way the carburettor works as regards the starting arrangement, and for other technical details.

Fig. 33

### Speedometer drive in housing cover - magneto side

Insert thrust washer **a** No. 0644 017 000. Grease the helical pinion **b** well - No. 0234 070 000 - place the spacing washer **c**, No. 0246 047 000 and bearing bush **d** No. 0233 073 000, on it and insert the assembly into the

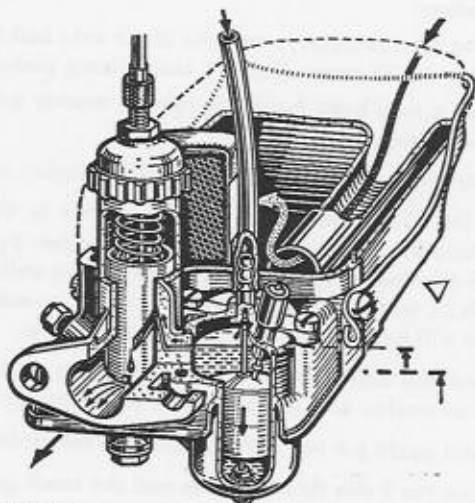

Fig. 32

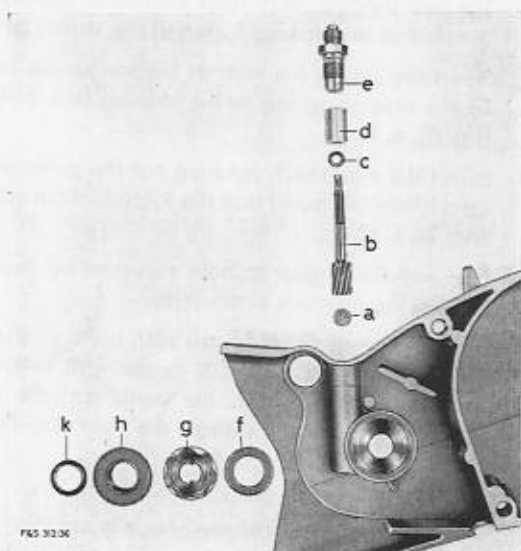

Fig. 33

housing cover. (Make sure that thrust washer **a** is seated properly). Screw in screw cap **e**. Then insert, likewise well greased, shim **f**, No. 0244 082 002, helical gear **g**, No. 0234 070 000 and bearing cup **h** with gasket **k** pressed in (its lip visible from the cover). Taking down is carried out accordingly in the reverse order.

## 6. ASSEMBLING THE ENGINE UNIT

### Gearbox

Using a screwdriver, screw the clutch side half-housing to the F. & S. work jig by two metric 6 x 20 screws (fig. 21). Insert fixing plates (fig. 23, **d**).

Insert a new buna (synthetic rubber) washer with cap protector for the selector lever if necessary.

Insert the selector lever, with a spring washer underneath it (fig. 25, **m**).

Fit the striking fork and its shim washer to the two ends of the selector lever and tighten the metric 6 bolt and spring washer by a 10-mm-spanner (fig. 25, **n, m, k, h**). The oil drain plug forms the guide for the striking fork at the same time; screw it in, with its washer, and tighten by a 14-mm spanner, making quite sure that the striking fork still moves quite freely; readjust it if not.

Insert the countershaft with ball-bearing bush and bronze driving sleeve, also the thrust washer with its chamfer towards the teeth (fig. 25, **g**).

Insert guide pin No. 0676 022 005 into the mainshaft bearing.

Place the 2 mm thrust washer and the small gearwheel (23 or 21 teeth, as the second speed gear ratio requires) on the guide pin.

The two slippers (with their centres of gravity towards the countershaft) can then be inserted in the striking fork and the striker plate pushed in (fig. 25, **d, e**).

Insert the spring pin with its tension spring into the housing from the clutch side and fix the tension spring to the striking fork with its open end towards the countershaft (fig. 25, **a, b**).

Insert the mainshaft, pressing out the guide pin at the same time, and place the large gearwheel (25 teeth) and the 9-tooth chain sprocket in position on it **without the chain** (fig. 24, **s, q**).

The pedalling gear spindle can now be inserted in the following order to check or line up the gearbox chain drive.

Thrust washer, driving bush with buna washer and 1.5 mm cover plate (the lip of the washer pointing inwards), driver with retarding spring (spring stirrup between the two guide webs), and the pedal spindle with chain wheel (but without packing washers and circlip) **without the gear chain** fig. 24, **n, g, /m-p, h**).

### Fig. 34

A straight edge or caliper gauge is used for checking the chain line. If the chain is not in line, the difference **a** is made up by inserting or removing packing washers **under** the chain wheel **b** on to or from the pedal spindle **c**, the sprocket being secured by a



circlip after packing washers have been placed on the sprocket. The end play of the pedal spindle sprocket is 0.1 to 0.2 mm. After the chain has been lined up the 9-tooth sprocket on the mainshaft and the pedal spindle with its chain wheel are again taken out of the half gear casing and then reassembled with the chain in position.

Fig. 35

**Main and countershaft and play Mainshaft** (for gear drive and chain drive): 0.1 – 0.2 mm.

**Countershaft:** For gear drive, 0.05 max.; for chain drive 0.05 – 0.1 mm.

This end play of the two gear shafts is found by means of the measuring plate No. 0277 026 000, the magneto side half-housing with its gasket and dowel pins being fitted temporarily and fixed with four screws, the compensation required for setting the prescribed end play being obtained by fitting shims on the mainshaft and countershaft.

#### Using the measuring plate

Both adjusting screws must be screwed back before setting up the measuring plate in position. It must then be placed on the shaft and secured by the knurled nut **e**. Press the plate and shaft against the housing and screw down one of the adjusting screws until it can be felt to touch the housing **f**. Then pull the plate and shaft up away from the housing and again screw the adjusting screw down until it touches the housing, reading the marks on the scale **g** at the same time. The result of the marks thus read gives the end play in the shaft measured (one mark equalling 0.1 mm.). This instruction applies equally to both shafts.

#### Crankshaft

The crankshaft No. 0290 029 000 on the Sachs 50 two-speed engine unit with gear drive has a "Z" marked on one crank web and the keyway in the magneto side crankshaft journal pointing downwards to the left. On chain-driven units, engines up to No. 2 304 588 (contact-breaker underneath), the crankshaft No. 0289 043 000

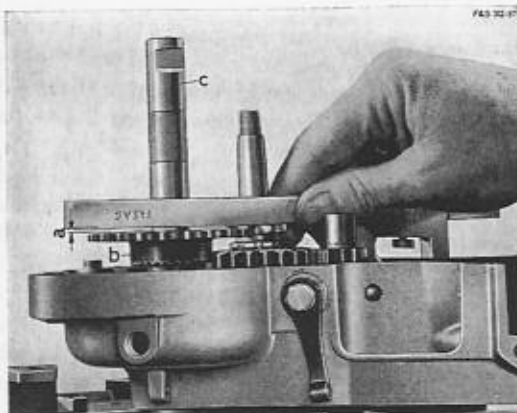

Fig. 34

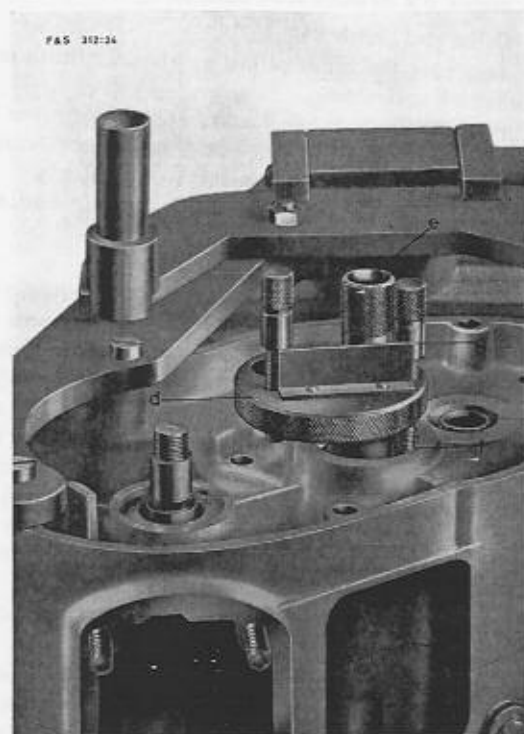

Fig. 35

has the journal keyway pointing to the left, while from engine No. 2 642 352 (0.8 H. P.) and also from engine No. 2 304 589 (1¼ H. P.), and from engine No. 2 654 450 (1.6 H. P.), with the contact-breaker on the right at the top, the crankshaft No. 0290 017 000 marked, with a "3" on one crank web has the magneto side crankshaft journal pointing downwards to the right.

So as not to injure the buna gasket in the half-housing when fitting the crankshaft already measured up and set to the prescribed end play, fit sleeve **g** No. 0278 022 000 on to the short crankshaft journal (with the chain-driven model, use sleeve **h**, No. 0277 078 000 (fig. 30).

Insert the crankshaft into the housing.

Examine the roller bearing, the "Abil" gasket for the housing, the two fitting sleeves and also the two fixing plates, as well as the rubber bush for the engine support.

Now screw the half-housing together with seven metric 6 x 20 screws and four metric 6 x 35 screws, using a screwdriver.

Remove the engine and gear unit from the work jig – taking out the two metric 6 x 20 screws by a screwdriver, and screw on again to the two rearward fixing eyes – two metric 8 x 50 bolts with nuts, using a 14-mm spanner (fig. 20).

### **Drive and clutch**

Degrease the taper of the ball-bearing bush and also the taper in the clutch housing before assembling.

Fit the Woodruff key for the driving gear into the crankshaft journal.

Place the driving gear wheel and clutch housing in position separately (measuring up and adjusting unnecessary) – fig. 19, **f**, **g**.

With chain drive, fit the clutch housing and main driving wheel without the key or chain first of all.

Check the chain line.

Place spacing washers under the main driving wheel as required.

Next, fit the Woodruff key in the crankshaft journal and fit the clutch housing and main driving wheel, connected by the chain. Insert the clutch holding plate No. 0278 008 000 into the clutch housing (fig. 16, **a**).

Tighten clutch housing with its locking plate and metric 20.8 nut (left-hand-thread) – with the collar downwards – and lock (26-mm box spanner) – fig. 18, **m**, **n**.

Tighten driving gear wheel with its locking plate and metric 10 nut (right-hand thread) and lock, using a 17-mm spanner (fig. 18, **h**, **k**).

On the chain-driven unit, tighten the main driving wheel with locking plate and metric 8 nut (right-hand thread) and lock, using a 14-mm spanner.

Fit Woodruff key to countershaft (fig. 18, **p**).

Degrease the taper on countershaft and the clutch centre, then place the latter in position (mind the Woodruff key).

Place the stop plate No. 0292 022 000 also in position and tighten the clutch centre with metric 12 nut and spring washer, using a 17-mm spanner (fig. 16, **b**).

Remove the clutch fixing plate and stop plate.

Grease the split clutch pin with its roller, and insert.

Insert clutch plates in the order one lined, one steel, one lined, and then the spring assembly, re-tightened by the special retaining fixture (thrust plate, six thrust springs and spring plate), fig. 15, **t**.

Push in the two cover plates fig. 15, **v**), release the retaining fixture **t** and take out (10-mm-spanner).

Make certain the two cover plates seat properly, readjusting them if necessary. Screw in the clutch adjusting screw **q**, metric 6, with lock nut **r**; adjust the clutch and then tighten the locknut **r**. The play on the clutch lever on the engine must be 8 to 10 millimetres (fig. 14). Fit on the clutch side half-housing with its "Abil" gasket, seeing that the buna washer is in place with its lip outwards.

Tighten the housing cover by five metric 6 screws (using a 9-mm screwdriver), applying a torque loading of 5.06 to 6.5 ft. lb.

Screw in and tighten the oil level check plug **c** with its washer (14-mm spanner) – fig. 36.

The clutch can be readjusted any time when the engine unit is back in the frame if the cover plate "S" be unscrewed (fig. 36, **a, b**).

### Fitting the brake lever

End play for driving bush and pedal spindle 0.1 to 0.2 mm in each case.

Spacing washers **h** must be placed on the ground collar of the driving bush (not in the recess turned behind the teeth), it being best to withdraw the pedal spindle slightly to do this.

The spacing must be taken up in such a way that the ground collar disappears completely by placing the spacing washers **h** in position, only the groove turned in the driving bush remaining free.

Place in position, one after the other, the serrated contact washer **g**, serrated brake lever **f** and the locking **k**. Tighten the metric 20.8 x 1 nut with the collar downwards (26-mm box spanner).

Turn the locking plate over against the side of the nut – fig. 13. (The torque loading for the metric 20.8 x 1 nut is 7.23 ft. lb. to 10.84 ft. lb.).

Then draw out the pedal spindle and fit with spacing washers up to the groove turned in it, leaving the groove free for the 1.5-mm circlip **s** which is fitted in by special circlip pliers (with the stop set to the exact opening width (fig. 13)).

### Piston

Remove any protruding part of the "Abil" gasket for the housing by a scraper. Place the cylinder flange gasket in position to fit the two transfer passages (fig. 10, **f**). Place the split wooden block (fig. 11, **a**) in position for the piston to rest on.

Warm the piston to 60 to 70° C and place on the connecting rod by fixing pins. The arrow on the piston (fig. 12) must point in the direction of travel, or the locating pin (fig. 11, **c**) of the top piston ring must point to the magneto side.

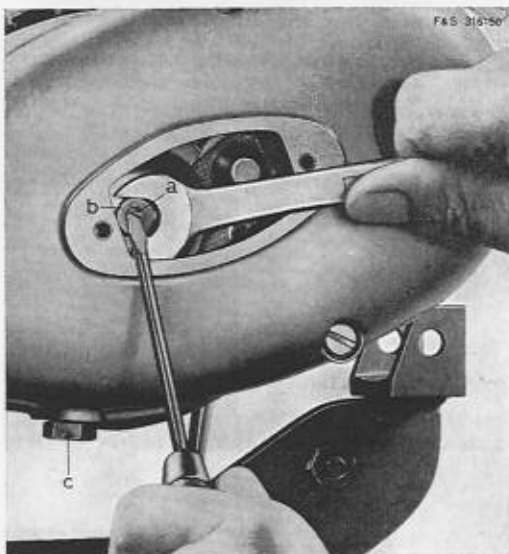

Fig. 36

Push the gudgeon pin in by hand; if necessary, draw in by means of the gudgeon pin extractor **e** and insert bush **d** No. 0277 083 000 (fig. 12). Pistons with a bushed bearing for the gudgeon pin must be lightly greased with high melting-point grease when fitting. Secure the gudgeon pin by circlips at both ends (fig. 11, **b**), making sure these circlips seat properly. Mind the piston rings when drawing the gudgeon pin in by the gudgeon pin extractor, as there is the risk of their being broken.

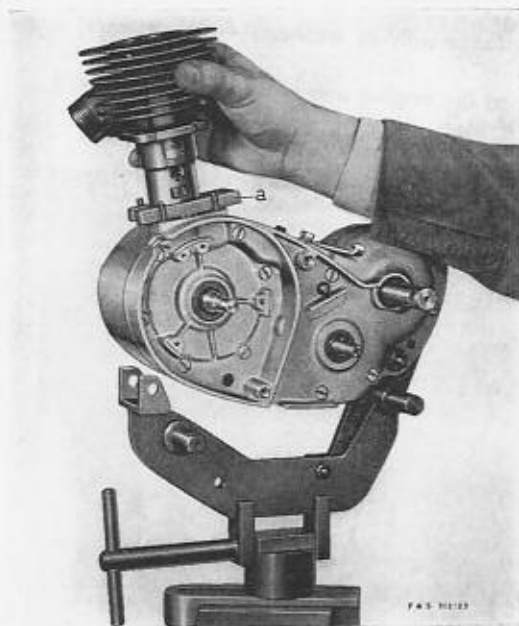

Fig. 37

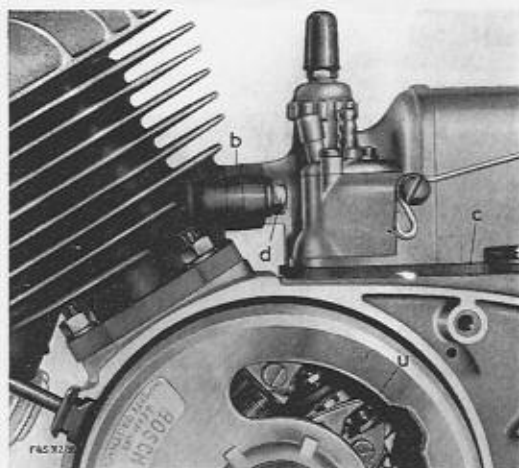

Fig. 38

Fig. 37

### Cylinder and cylinder head

Oil the cylinder and place it in position without turning it, taking the wooden block away first **a**. Screw the cylinder down lightly by four metric 6 nuts and spring washers. The engine should then be turned over a few times and then the cylinder tightened diagonally, using a 10-mm ring or open-ended spanner.

Bolt the cylinder head on diagonally – four bolts with plain washers – using a 10-mm spanner. So that there may not be any twist in the frame, it is advisable when fitting the engine unit into the frame to loosen the cylinder head again and to retighten it after bolting the engine into the frame.

Fig. 38

### Carburettor

Fit the asbestos washer **b** for the carburettor on to the cylinder flange; place the rubber or cork gasket **c**, No. 0230 010 006, for the carburettor, on to the housing and fix by adhesive (jointing compound) if necessary. The two special "Novotex" steel washers **d** are to be placed with their "Novotex" sides against the carburettor flange, the carburettor being bolted on by two metric 5 nuts (9-mm spanner).

Screw in the oil filling plug (fig. 3, **d**).

### Driving sprocket

Fit the Woodruff key to the mainshaft. Degrease tapers in the sprocket and on the mainshaft. Place sprocket in position with its spring washer and tighten its metric 10 nut by a 17-mm spanner. (If the speedometer drive is in the cover, the nut is a metric 10 slotted one for tightening by a 14-mm spanner (fig. 5).

Fig. 39

### "Bosch" flywheel magneto for ignition and lighting

Fit Woodruff key **a** to crankshaft. Fit the armature baseplate into the housing (contact-breaker at top right-hand), with the round rubber grommets **e** for the lighting cable (yellow), the contact-breaker cable (black) and the long rubber grommet **d** for the ignition cable with the rounded ends in first, tightening by three metric 4 screws **b** with washers and spring washers (screwdriver) – fig. 9. The chisel cut **k** on the armature baseplate must register with a similar mark on the housing (fig. 9).

Degrease the taper on the crankshaft and in the magneto flywheel, then place the latter in position (being careful with the key). Set the retaining strap of the work jig (fig. 8, **m**) in the slot in the magneto flywheel under tension and tighten the metric 10 x 1 flanged nut with its spring washer, using a 14-mm spanner; torque loading, 18 to 21.7 ft. lb.

Fig. 40

### Ignition setting

Ignition advance: 2 to 2½ mm.  
Contact-breaker points gap: 0.35 to 0.45 mm.

There are two marks stamped on the magneto flywheel; the "O" is in line with the mark on the housing when the piston is at t. d. c. (fig. 39, **m**), while "M" gives the correct ignition advance (2 to 2½ millimetres) –

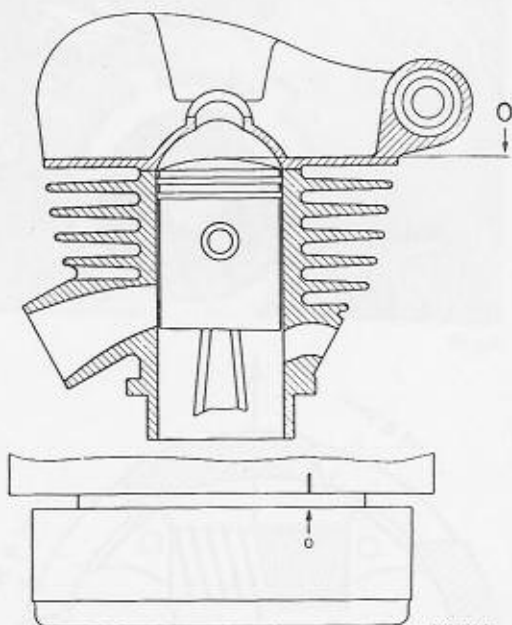

Fig. 39

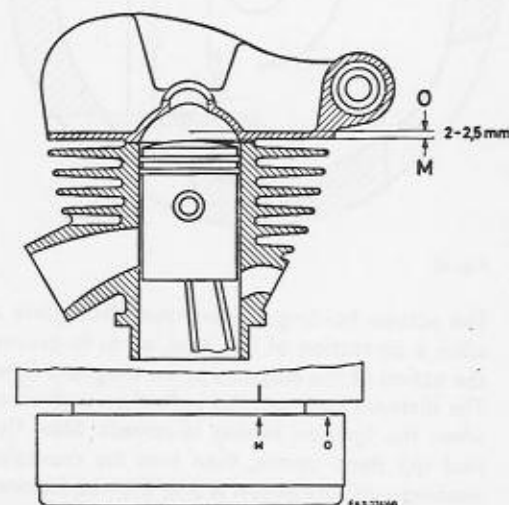

Fig. 40

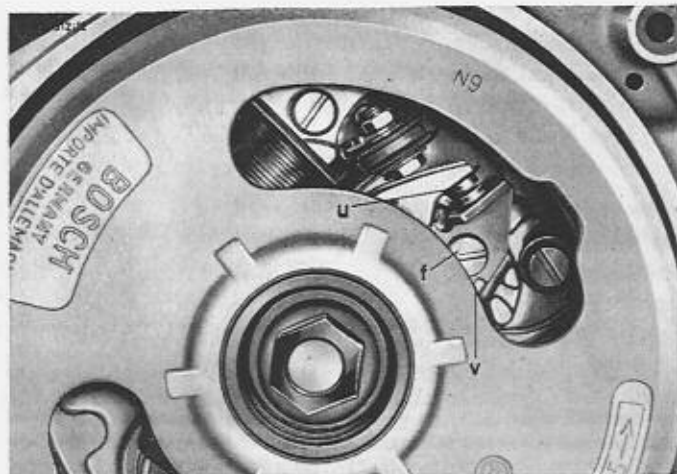

Fig. 41

Fig. 41

The contact-breaker points must be set so that with the maximum lift of the cam they separate 0.35 to 0.45 mm (fig. 41, n). This is done by slackening the screw (fig. 41, f) holding the contact plate and moving the plate in its adjusting slot (fig. 41, v) by a screwdriver.

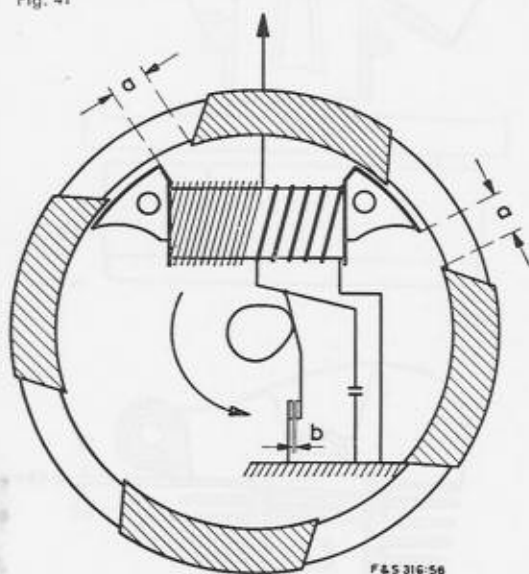

Fig. 42

Fig. 42

The ignition point is found by setting the magneto flywheel to the "M" mark, and the contacts or points must just commence to open in this position (commencement of ignition).

Ignition advance can be corrected by turning the armature baseplate in the longitudinal slots. Turning it **against** the direction the engine rotates **advances** the ignition; turning it the way the engine runs **retards** the ignition. Caution: The engine unit with gear drive runs left-handed, i. e., anticlockwise; chain-drive units have engines running right-handed, or clockwise.

The screws holding the armature baseplate must always be firmly tightened again after a correction of this kind, so as to prevent the baseplate being turned round by the action of the magnets in the magneto flywheel.

The distance between the pole shoe and armature core is 6 to 11 millimetres (fig. 42) when the ignition setting is correct. New flywheel magnetos are not marked. First find top dead centre, then turn the crankshaft backwards against the direction of running until the piston is 2 to 2½ mm before t. d. c.; the new "M" mark can then be stamped or cut opposite the mark on the housing.

Figs. 40, 41 and 42 show left-hand, i. e., anti-clockwise running.



### Spark plug, W 175 T. 11 or W. 190 M. 11 S.

See that the gap at the plug points is 0.4 to 0.5 mm; if enlarged, the prescribed gap can be reset by bending the earth electrode of the plug, i. e., the one at the side.

It is advisable to check or readjust the ignition, as the case may be, at every inspection, since the engine's output depends on correct ignition and various lighting troubles owe their origin to faulty ignition adjustment.

Pour 200 c. c. of SAE 80 gear oil into the opening on the clutch side (the "S" plate), then screw the "S" plate back into position after replacing the cork washer, using a screwdriver for the two oval-headed screws (fig. 3, a).

Smear the magneto side housing cover with jointing compound and screw up by two metric 6 screws, using a screwdriver (in most cases after the chain has been placed in position).

Where the speedometer drive is built into the cover, be careful to see that slotted nut (fig. 5, p) on the driving chain sprocket engages in the helical pinion of the speedometer drive (fig. 33, g).

Remove the engine/gear unit from the F. & S. work jig.



## 7. FITTING THE ENGINE UNIT INTO THE FRAME

Tighten the engine down by the three fixing bolts, nuts and locking plates.

### Fit the brake linkage to the brake lever on the engine unit.

Place the washers on and secure by a split pin. Put on the chain to the rear wheel and close by the connecting link. The locking spring must point its closed end in the direction the chain runs. Screw on the chain guard. Fit and adjust Bowden clutch cable (fig. 43).

The Bowden cable for the clutch is fitted into the engine unit clutch lever **a** and the Bowden adjuster set **b** so as to give 1 to 3 mm play **c** on the handlebar clutch lever. The play on the engine unit clutch lever itself is 8 to 10 mm.

### Fit the brake linkage to the brake lever on the engine unit.

Screw the Bowden adjuster **c** into the eye on the engine. Pass the Bowden cable (inner member) **d** through the adjusting screw **c** and the gear-change lever **e**; likewise, pass the Bowden casing **f** with the inner cable well lubricated in it, into the gear change twist grip **g**.

Fig. 44 shows the two possible ways of arranging the Bowden control; we recommend using the type shown in the left-hand sketch, where possible. If now second gear is engaged, slight play must be felt in the Bowden casing. If necessary, readjust the adjuster **c**.

Change over to neutral. De clutch, turn the rear wheel and engage first gear slowly by the twist grip control until slight locking of the gears is felt (the selector pins rubbing on the selector plate). In this instance, see that the mark on the twist grip is between 0 and first gear.

Second gear is engaged from neutral in the same way, and similarly when the gear starts to engage the position of the mark must be checked. Differences in the travel of the control from 0 to first or second gear, as the case may be, must be taken up on the Bowden adjuster **c** to prevent any gear-changing difficulties from the outset.

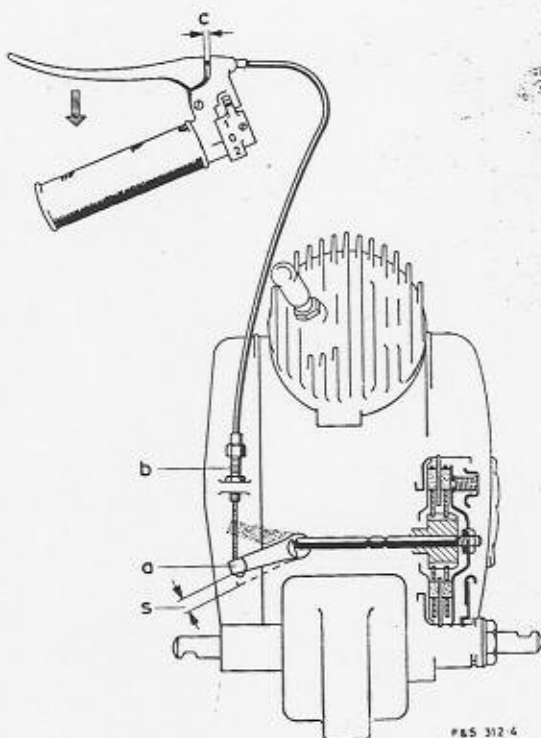

Fig. 43

#85 312 4



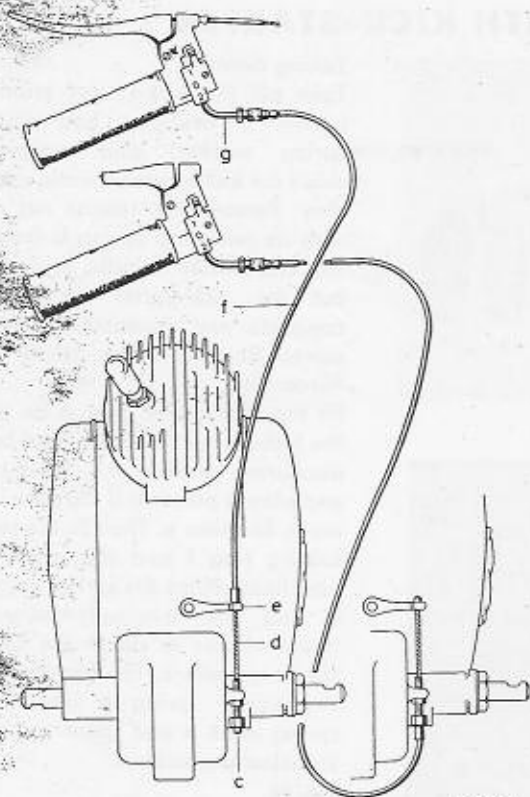

Fig. 44

F&S 310 3

#### **Fit carburetter Bowden control.**

Screw the mixing chamber cover with the gas slide, or throttle, on to the carburetter.

#### **Petrol pipe.**

Connect the petrol pipe to the petrol tap, or fit the flexible petrol pipe on to the carburetter, as the case may be.

#### **Assemble pedalling gear.**

Fit the cranks on the left and right sides and fix by cotters, washers and nuts.

#### **Exhaust pipe and silencer.**

Having cleaned the exhaust system, fit it, with its washer, and tighten up well by the exhaust cap nut. Make sure that the silencer and pipe joints fit perfectly.

#### **Electrical connections.**

Connect the two cable clips for the lighting cable (yellow) and the short-circuiting cable (black) and screw together.

## 8. THE SACHS 50 WITH KICK-STARTER

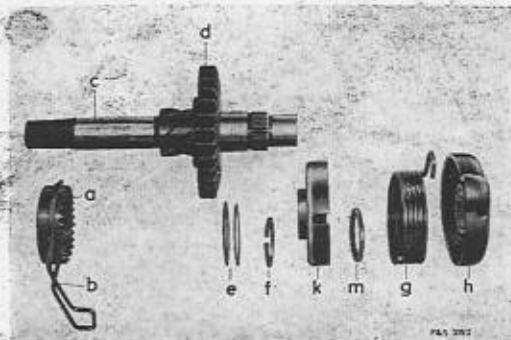

Fig. 45

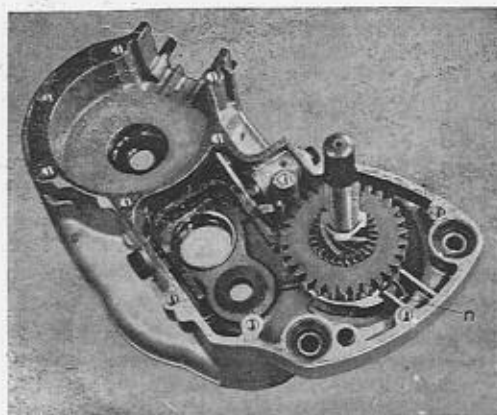

Fig. 46

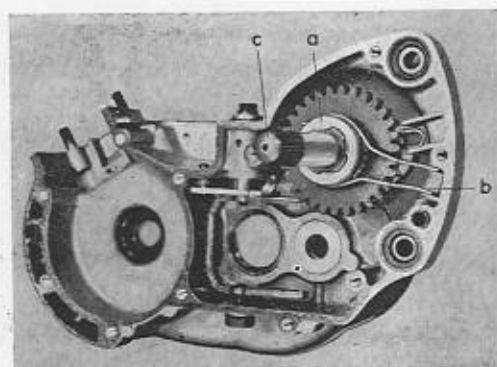

Fig. 47

The kick-starter crank can be fixed on after the left-hand side housing cover, or the fan casing, as the case may be, has been screwed on, and tightened by the metric 6 hexagon bolt and spring washer. (Check the direction of rotation of the starter).

### Taking down.

Take off the kick-starter crank (metric 6 hexagon bolt and spring washer) and remove shims for kick-starter spindle end play. Remove the rosette nut **a** with its retarding spring **b** from the kick-starter spindle **c**. Take out the kick-starter assembly complete and dismantle as required. Remove the mainshaft.

### Assembling.

Fit the kick-starter gear **d** on to the kick-starter spindle **c**. Find by measuring whether 0.1–0.2 mm end play is present; if the play is more, fit shims **e**. Then fit the retaining ring **f** and the gear is now fixed. Place the spring drum **k** and the internally-toothed thrust washer **m** on to the kick-starter spindle **c**. Fix the end of the starter spring **g** into the spring plate **h** and fit on to the kick-starter spindle **c**.

### Fig. 46

Insert the complete kick-starter with its spindle far enough into the bore of the bearing for the starter spring to be placed under tension and also secured in the retaining slot **n** at the same time. When the spring has been tensioned, the complete kick-starter assembly can be fitted into the bearing.

### Fig. 47

Fit the rosette nut **a** with its retaining spring **b** on to the kick-starter spindle **c** and then continue assembling the engine/gear unit as already described under No. 6 in "Assembling the engine unit".