

The N

cal.

***RALEIGH***

*Supermatic*

**MOPED**

**MODEL RM5**

**WORKSHOP MANUAL**

**Price 9/6**



***RALEIGH***

***Supernatic***

**MOPED**

**MODEL RM5**

**WORKSHOP MANUAL**





# INDEX

	Page
<b>INTRODUCTION</b> .. .. .	4
<b>Technical Data</b> .. .. .	5
<b>Recommended Lubricants</b> .. .. .	6
<b>Notes on Workshop Practice</b> .. .. .	7
<b>Fault Finding</b> .. .. .	47
<b>Shim Washers for Adjustment Purposes</b> .. .. .	52
<b>Special Workshop Tools</b> .. .. .	50
<b>FRAME AND CYCLE PARTS — SERVICING</b> .. .. .	35
<b>FRONT FORKS</b> .. .. .	35
<b>Front Forks—Removing</b> .. .. .	35
<b>Front Forks—Dismantling</b> .. .. .	35
<b>Front Forks—Reassembling</b> .. .. .	36
<b>Front Forks—Refitting</b> .. .. .	35
<b>Steering Head Bearings—Adjusting</b> .. .. .	36
<b>FRONT WHEEL</b> .. .. .	36
<b>Front Wheel—Removing</b> .. .. .	36
<b>Front Wheel Hub—Dismantling</b> .. .. .	37
<b>Front Wheel Hub—Reassembling</b> .. .. .	37
<b>Front Wheel Brake Shoes—Replacing</b> .. .. .	38
<b>Front Wheel—Refitting</b> .. .. .	36
<b>HANDLEBAR, CONTROLS AND CABLES (EARLY MODEL)</b> .. .. .	41
<b>Control Cables—Adjusting</b> .. .. .	42
<b>Control Cables—Replacing</b> .. .. .	43
<b>Handlebar—Adjusting</b> .. .. .	41
<b>Handlebar—Removing</b> .. .. .	41
<b>Handlebar—Refitting</b> .. .. .	41
<b>Twistgrip</b> .. .. .	42
<b>HANDLEBAR, CONTROLS AND CABLES (LATER MODEL)</b> .. .. .	44
<b>Control Cables—Adjusting</b> .. .. .	44
<b>Control Cables—Replacing</b> .. .. .	44
<b>Handlebar—Adjusting</b> .. .. .	44
<b>Twistgrip</b> .. .. .	44

# INDEX—continued

	Page
<b>LIGHTING SYSTEM AND SPEEDOMETER CABLE</b> .. .. .	45
Headlamp—Setting .. .. .	45
Rearlamp .. .. .	45
Wiring Diagram .. .. .	45
Speedometer Cable .. .. .	46
 <b>REAR SUSPENSION</b> .. .. .	 40
Rear Suspension Unit—Removing .. .. .	41
Rear Suspension Unit—Refitting .. .. .	41
Rear Swinging Fork—Removing .. .. .	40
Rear Swinging Fork—Refitting .. .. .	40
 <b>REAR WHEEL</b> .. .. .	 38
Rear Wheel—Removing .. .. .	38
Rear Wheel Bearings—Replacing .. .. .	39
Rear Wheel Brake Shoes—Replacing .. .. .	40
Rear Wheel—Refitting .. .. .	38
 <b>POWER UNIT — SERVICING</b> .. .. .	 8
 <b>AUTOMATIC CLUTCH/GEAR UNIT</b>	
Clutch Drum—Removing .. .. .	15
Clutch Drum—Relining .. .. .	17
Clutch/Gear Body—Removing .. .. .	15
Clutch/Gear Body—Dismantling .. .. .	17
Clutch/Gear Body—Reassembling .. .. .	18
Clutch/Gear Unit—Refitting .. .. .	16
 <b>ENGINE REMOVING AND ROUTINE MAINTENANCE</b>	
Decarbonising .. .. .	12
Exhaust System—Decarbonising .. .. .	12
Engine—Decarbonising .. .. .	12
Decompressor Valve .. .. .	13
Drive Belt—Replacing .. .. .	11
Drive Belt Tensioning Spring—Replacing .. .. .	11
Engine—Removing .. .. .	8
Engine Upper Mounting Bushes—Replacing .. .. .	10
Engine—Refitting .. .. .	9
Exhaust Silencer Mountings .. .. .	10

# INDEX—continued

	Page
<b>ENGINE DISMANTLING AND REASSEMBLING .. .. .</b>	<b>23</b>
Cylinder and Piston—Dismantling .. .. .	24
Crankcase—Dismantling .. .. .	25
Main Bearings—Removing .. .. .	26
Crankcase—Reassembling .. .. .	26
Piston Sizes .. .. .	27
Piston—Refitting .. .. .	27
Piston Rings .. .. .	27
Cylinder—Refitting .. .. .	28
 <b>FLYWHEEL MAGNETO .. .. .</b>	 <b>19</b>
Flywheel—Removing .. .. .	20
Contact Breaker Points .. .. .	20
Contact Breaker—Replacing .. .. .	21
Magneto—Timing .. .. .	21
Condenser—Replacing .. .. .	22
Coils—Replacing .. .. .	22
Stator Plate—Removing .. .. .	22
Flywheel—Refitting .. .. .	20
 <b>FUEL SYSTEM .. .. .</b>	 <b>28</b>
Carburettor—Adjusting .. .. .	30
Carburettor—Removing .. .. .	28
Carburettor—Dismantling .. .. .	30
Carburettor—Reassembling .. .. .	30
Carburettor—Refitting .. .. .	29
Fuel Tap—Cleaning .. .. .	31
 <b>TRANSMISSION — SERVICING .. .. .</b>	 <b>31</b>
Chains—Adjusting .. .. .	34
Chains—Lubricating .. .. .	34
Bottom Bracket Axle—Removing .. .. .	31
Bottom Bracket Axle Bearings—Replacing .. .. .	32
Bottom Bracket Pulley—Removing .. .. .	31
Bottom Bracket Pulley Bearings—Replacing .. .. .	33
Bottom Bracket Pulley—Dismantling .. .. .	32
Bottom Bracket Pulley—Reassembling .. .. .	34
Bottom Bracket Pulley—Refitting .. .. .	32
Bottom Bracket Axle—Refitting .. .. .	32



## **INTRODUCTION**

Our object in producing this Moped has been to provide motorised transport which is inexpensive to buy, economical to run and easy to ride and maintain. The machine incorporates the latest continental technical developments and is manufactured to the highest standards of craftsmanship and quality.

This Workshop Manual is to provide Dealers and their mechanics with all possible information and advice to enable them to provide an efficient service to the customer.

At the same time, however, it is accepted that the enthusiastic owner will wish to carry out some, if not all, of his own repairs and it is with this in mind that the sections have been compiled. Should the experienced mechanic find some sections unnecessarily detailed, we hope he will bear with us in our attempt to provide all relevant information to the novice.

Mention should be made here of the Special Workshop Tools which are available, a list of which is on Page 50 of this book. Whilst some of these are indispensable to the professional repairer, it should be borne in mind by the private owner that the cost of certain of these tools is unlikely to be justified if they are only to be used for the maintenance of one machine.

**RALEIGH INDUSTRIES LIMITED**

**MOTORISED DIVISION SERVICE DEPARTMENT**

**LENTON BOULEVARD**

**NOTTINGHAM**

**TELEPHONE: 77761**

**TELEGRAMS: "RALIND"**

**TELEX: 37681**

**An illustrated Spare Parts List covering this model is  
available at a price of 3/- post free.**



## TECHNICAL DATA

### ENGINE

Type: Single cylinder, two-stroke with twin transfer ports. Aluminium alloy cylinder with hard chrome plated bore. Aluminium alloy cylinder head and piston. Cast iron piston rings.

Bore: 39 mm.

Stroke: 41.75 mm.

Cubic capacity: 49.9 cc.

Compression ratio: 9 : 1.

Maximum B.H.P.: 2.66 at 5,600 r.p.m.

Piston clearance bottom of skirt: 0.0004" min. 0.0008" max.

Piston ring gap: 0.004" min. 0.008" max.

Small end needle roller bearing size: 16 mm. O.D., 13 mm. I.D., 14 mm. L.

Crankshaft main bearings size: 42 mm. O.D., 16 mm. I.D., 13 mm. W.

Crankshaft end float: 0.004" min. 0.008" max.

### IGNITION

Type: Flywheel magneto. NOV1 model 120X with external H.T. ignition coil.

Contact breaker points gap: 0.016"—0.018".

Ignition advance:  $\frac{1}{16}$ " (0.063"  $\pm$  0.004") before T.D.C.

Sparking plug: Lodge 2HN; Champion L86; KLG F80.

Sparking plug electrode gap: 0.016"—0.018".

### CLUTCH

Type: Automatic, centrifugally operated.

### PRIMARY DRIVE

Type: Vee-belt.

Ratio: Variable, 2.78 to 4.98 : 1.

### FINAL DRIVE

Type: Enclosed roller chain.

Ratio: 4 : 1 (48t to 12t).

Chain size:  $\frac{1}{2}$ " x  $\frac{7}{16}$ " x 0.305" roller x 103 pitches.

**OVERALL GEAR RATIO** 11.1—19.9 : 1.

### PEDAL DRIVE

Type: Roller chain.

Ratio: 1.78 : 1 (32t to 18t).

Chain size:  $\frac{1}{2}$ " x  $\frac{1}{8}$ " x 03.05" roller x 93 pitches.

### ELECTRICAL SYSTEM

Type: NOV1 18 w. Alternator.

Headlamp diameter: 4.0".

Headlamp bulb: 6 v., 15 w., S.C.C.

Rearlamp bulb: 6 v., 3 w., M.E.S.

Electric horn: High frequency, 6 v., 15 w., A.C.

### FUEL SYSTEM

Tank capacity:  $1\frac{1}{8}$  galls. (inc. reserve).

Carburettor: GURTNER H.14. 569 F.

Main jet size: No. 25.

### TYRES

Size  $22\frac{1}{2}$ " x  $2\frac{1}{4}$ "

Pressures (lbs. per sq. in.)

Solo: Front 22, Rear 31

Pillion: Front 23, Rear 56

### BRAKES

Type: Cable operated, internal expanding.

Drum diameter: 100 mm.

# M O P E D   W O R K S H O P   M A N U A L

## DIMENSIONS

Overall length: 5 ft. 10 in.  
 Overall height: 3 ft. 3 in.  
 Overall width: 1 ft. 11 in.  
 Weight: 112 lbs.

## FRAME NUMBER

Frame steering head.

## ENGINE NUMBER

Lower front of cylinder barrel.

## RECOMMENDED LUBRICANTS

		BP	Castrol	Esso	Mobil	National Benzole	Shell
<b>Engine</b> Petrol/oil ratio shown in brackets	Two-Stroke Oils	Energol Two-Stroke Oil (20 : 1)	Two-Stroke Self-mixing Oil (16 : 1)	Esso Two-stroke (2T) Motor Oil (16 : 1)	Mobilmix TT (16:1)	—	Shell 2T Two-Stroke Oil (20:1)
	Pre-Mixed fuels	B.P. Zoom (20 : 1)	—	—	—	Hi-Fli* (20 : 1)	Shell 2T Mixture (20:1)
Running in: Where a (20 : 1) ratio is specified, use (16 : 1) for running in. Where a (16 : 1) ratio is specified, use (12 : 1) for running in.							
<b>Chains and Expanding Pulley Balls</b>	Grade	Energol SAE 50	Grand Prix	Esso Extra Motor Oil 40/50	Mobiloil BB	—	Shell X-100 50
<b>Working Joints, Control Cables, Etc.</b>	Grade	Energol SAE 20W	Castrolite	Esso Extra Motor Oil 20W/30	Mobiloil Arctic	—	Shell X-100 20W
<b>All Greasing Applications</b>	Grade	Energol L2	Castrol LM	Esso Multi-Purpose Grease H	Mobil-grease MP	—	Retinax A

\* NATIONAL BENZOLE CO. LTD., ALSO MARKET SHELL & B.P. LUBRICANTS



## NOTES ON WORKSHOP PRACTICE

### PRELIMINARY CLEANING

Before commencing any dismantling or repair work it is always advisable to clean the machine thoroughly, or at least the parts on which the repair work is to be carried out and those adjacent. It often happens that during this preliminary cleaning, one can spot faults which otherwise might pass undetected, such as loose or missing nuts and bolts, damaged or worn components, etc.

Too much emphasis cannot be laid on the need for tidiness and cleanliness of the workbench, the tools and all the other equipment to be utilised.

A plentiful supply of clean rags or cotton waste should be at hand, as it is all too easy to transfer dirt and grit to vital working parts by using soiled rags.

### TOOLS

For all dismantling and assembly work, use spanners, tools and extractors in good condition. Avoid the use of improvised or inefficient equipment, which often results in a loss of time and is liable to damage the parts.

### SEQUENCE OF DISMANTLING

When dismantling, take careful note of the sequence of removal of the various components, in order to

be able to reassemble them in the correct order. On no account mix the parts with similar ones belonging to other machines.

### GASKETS

As a general rule, always use new gaskets. These should be smeared with grease. The use of adhesive jointing compounds is to be avoided, due to the difficulty of removing them once they have set.

### BALL BEARINGS

The bearing tracks and balls must show a surface which is uniformly polished and bright. If signs of roughness or pitting are detected at any point, the bearing must be changed. Check that the cages, too, are in perfect condition.

If play is apparent after the bearing has been washed in clean paraffin and re-oiled, it is worn and should be discarded. Bear in mind, however, that the interference fit of the bearing in its housing tends to reduce the running clearance.

### FITTING SHIMS

Carefully note the position of all washers and shims when dismantling and replace them when re-assembling. A list of washers and shims supplied for adjustment purposes is given at the back of this book.

## POWER UNIT — SERVICING

### ENGINE REMOVAL AND ROUTINE MAINTENANCE

#### REMOVING ENGINE UNIT

The fairings on each side of the machine must first be detached. These are each secured by three knurled screws. Disconnect the sparking plug suppressor cap and the low tension wire from the external ignition coil. (See Fig. 1). Withdraw the wire carefully through the holes in the frame. Pull off the lighting wire which is clipped to the terminal behind the magneto stator plate. (See Fig. 2). To disconnect the decompressor cable, depress the valve in the cylinder head with the fingers and guide the inner cable out from the loop in the end of the valve spring. Now unhook the cable nipple from the stop plate on the cylinder head.

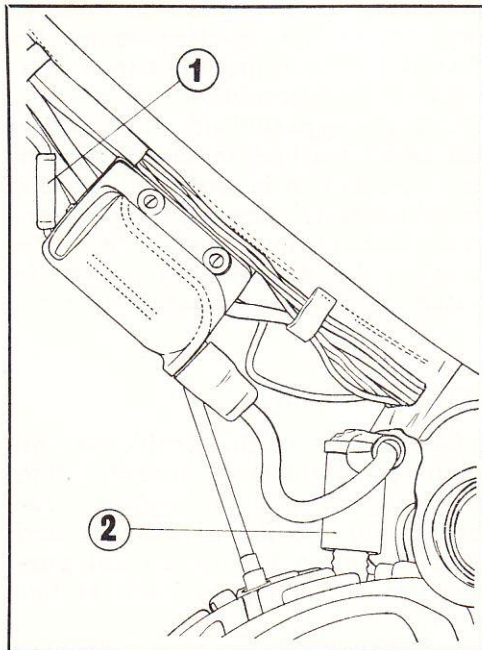


Fig. 1

1. Ignition low tension wire
2. Suppressor cap

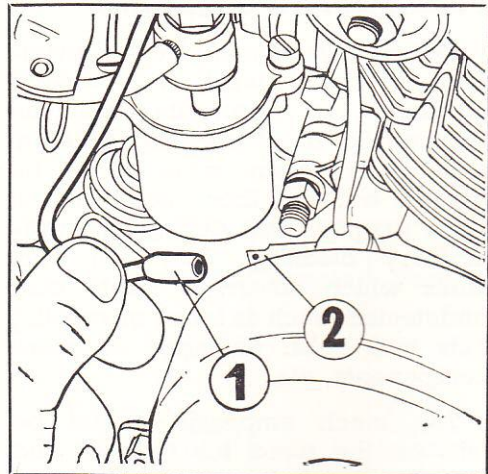


Fig. 2

1. Lighting wire
2. Lighting terminal

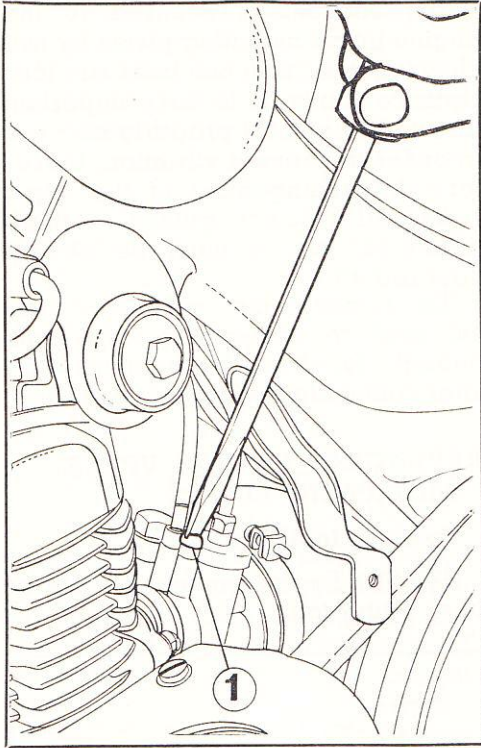
Ensure that the fuel tap is turned off and unscrew the cap nut from the top of the carburettor float chamber. This will allow the fuel pipe to be removed complete with the carburettor banjo union. Place the filter in a safe place.

Loosen the carburettor clamping ring and tilt the carburettor top towards the left of the machine, in order to allow easy access for a screwdriver to the screw which secures the mixing chamber cover. Remove the screw (See Fig. 3) and carefully lift off the cover together with the throttle and enrichment valves (See Fig. 4).

The carburettor can now be eased from its mounting stub.

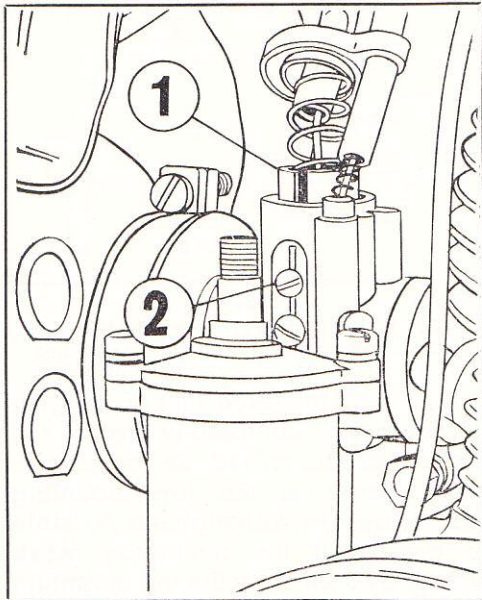
Take out the three screws which retain the clutch guard and remove the guard. Push the engine back against the tensioning spring and remove the belt, taking it off the bottom bracket pulley first (See Fig. 5).





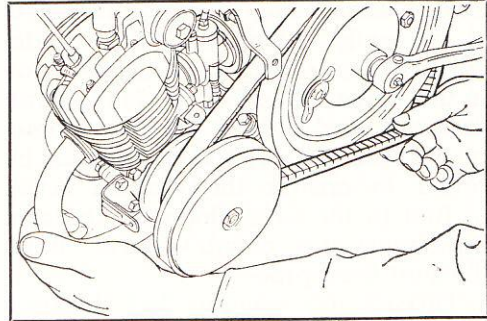
**Fig. 3**

1. Mixing chamber cover screw



**Fig. 4**

1. Throttle valve guide slot
2. Guide screw



**Fig. 5—Removing drive belt**

Remove the nut and bolt holding the tensioning spring to the bracket on the lower engine plate. Remove the nut from the upper engine mounting bolt and carefully supporting the engine in order to prevent it dropping, withdraw the mounting bolt, having taken note of the position of the shouldered washers and spacing tubes.

Remove the engine, complete with the exhaust system.

## REFITTING ENGINE UNIT

Place the top mounting bolt in position through the left-hand rubber mounting bush and fit the 4 mm. spacing tube adjacent to the inner side of the bush. Insert the two shouldered washers in the cylinder head lug, support the engine in its approximate position relative to the frame and push the top mounting bolt through. Next place the terminal of the engine earth wire on to the top mounting bolt followed by the long (39 mm.) distance tube. Continue the assembly of the top mounting by pushing the bolt through the right-hand rubber mounting bush and loosely fitting the nut and shake-proof washer. (See Fig. 32).

Line up the lower engine mounting bracket with the rubber bush in the end of the belt tensioning spring and insert and tighten the lower mounting bolt. Refit the carburettor to its stub. When replacing the mixing chamber



cover, ensure that the throttle valve is correctly fitted, i.e., the guide screws are engaged with the slot in the valve. (See Fig. 4). Make sure that the carburettor is fully home on its stub and that it is vertical, in order to ensure the correct level of fuel in the float chamber, before tightening the clamp screw. Refit the fuel feed pipe.

Thread the ignition low tension wire back through the holes in the frame and through the cable retaining bracket, clip the terminal to the external H.T. coil, connect the lighting wire to the terminal at the back of the magneto stator plate and refit the sparking plug lead and decompressor cable. Push the engine back to compress the spring, fit the drive belt and tighten the upper mounting bolt. Replace the clutch guard and fairings.

## SILENCER MOUNTINGS

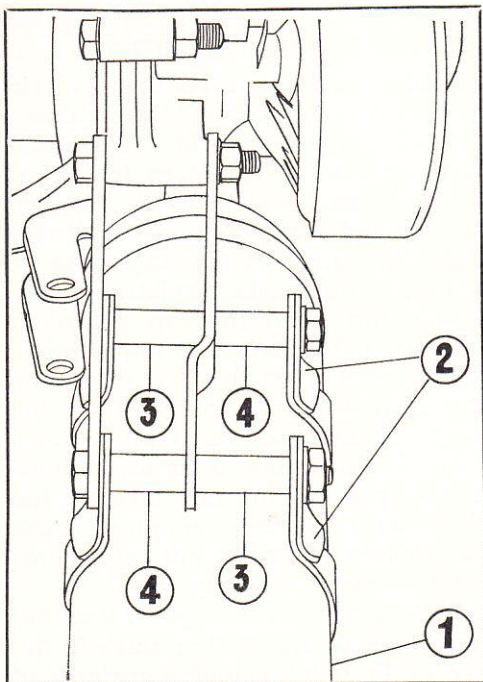


Fig. 6

### Silencer mountings

- |                   |                          |
|-------------------|--------------------------|
| 1. Silencer       | 3. Long distance pieces  |
| 2. Silencer clips | 4. Short distance pieces |

The silencer is secured to the engine lower mounting plates by two clips together with two bolts and four distance tubes. It is very important that the silencer is properly secured in order to prevent vibration, therefore the arrangement of the clips, bolts and distance pieces as illustrated in Fig. 6 must be strictly adhered to.

To remove the silencer, it is sufficient to loosen the clip bolts enough to slide the silencer out, after removing the exhaust pipe.

## REPLACING ENGINE UPPER MOUNTING BUSHES

**Special tool available.**

6200570 Engine mounting rubber bush fitting tool.

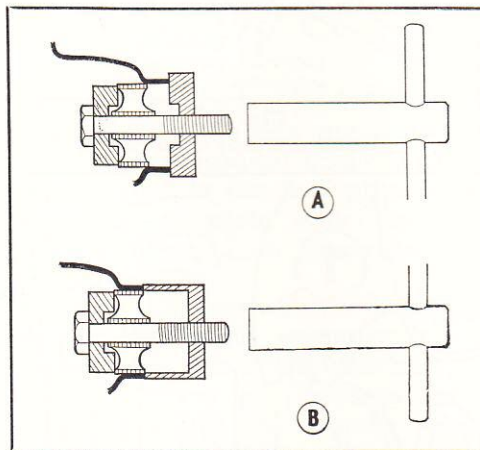


Fig. 7

- A. Fitting engine mounting bushes  
 B. Removing engine mounting bushes

It is recommended that the engine is removed completely from the frame, as described on page 8 to give access to the top mounting rubber bushes, although it is possible to carry out the necessary work simply by taking out the top mounting bolt. If the latter course is adopted, care must be taken to ensure that the engine does not hang by the



control cables, etc., and so impose unnecessary strain on them.

The manner of using the special tool for both extracting and fitting the bushes is illustrated in Fig. 7. If the special tool is not available, a similar arrangement of drawbolt, tube and thick washers of appropriate sizes will do the job almost as well.

If the mounting bushes are being fitted to a new frame, ensure that there is no excessive thickness of paint in the bracket to make the fitting operation unnecessarily difficult.

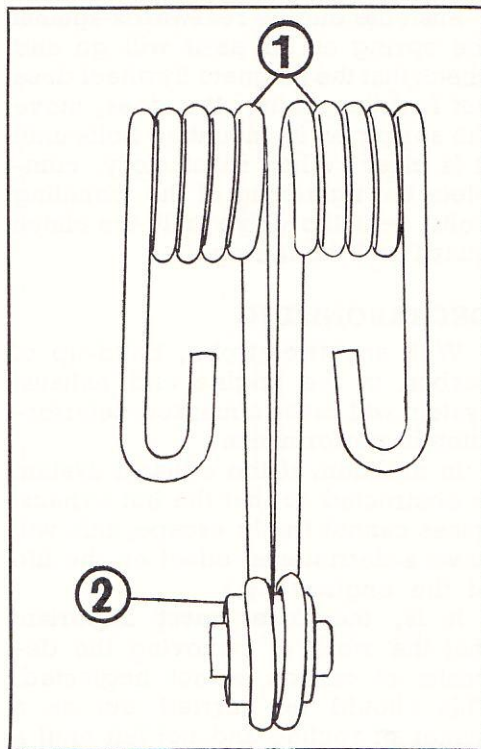
## FITTING A NEW DRIVE BELT

To remove the drive belt, it is only necessary to remove the left-hand fairing and the clutch guard, push the engine rearwards against the belt tensioning spring and loop off the belt, taking it off the bottom bracket pulley first. (See Fig. 5). Reverse this procedure to fit the new belt. Note that the belt tension adjustment is taken care of automatically by the belt tensioning spring.

## REPLACING BELT TENSIONING SPRING

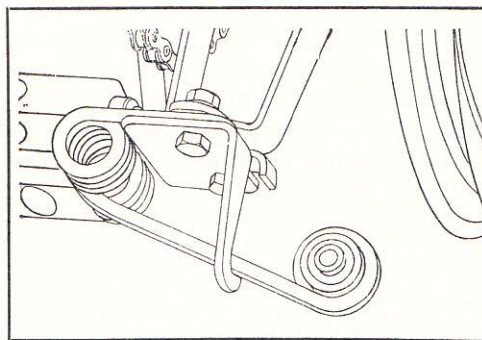
Remove both fairings and the clutch guard to gain access to the spring mountings. Remove the drive belt. Take out the bolt which connects the spring to the bracket on the lower engine plate and detach the spring by removing the two bolts which secure it to the frame bracket. The two halves of the spring may be separated by pressing out the rubber bush.

When refitting, assemble the two halves of the spring on the bush as shown in Fig. 8. Place the spring in position on the frame bracket, followed by the spring retaining bracket (See Fig. 9) and fit, but do not fully tighten the two mounting bolts. Compress the spring and



**Fig. 8**

1. Belt tensioning spring
2. Lower engine mounting bush



**Fig. 9**

Correct assembly of belt tensioning spring

engage the free end with the hook on the retaining plate; align the bracket on the lower engine plate with the rubber bush and fit and tighten the nut and bolt.



Push the engine rearwards against the spring as far as it will go and check that the magneto flywheel does not foul the spring. If it does, move the spring on its mounting bolts until it is clear. When satisfactory, complete the tightening of the mounting bolts, refit the drive belt, the clutch guard and the fairings.

## DECARBONISING

With any two-stroke, build-up of carbon in the engine and exhaust system will cause a marked deterioration in performance.

In addition, if the exhaust system is obstructed so that the hot exhaust gases cannot freely escape, this will have a detrimental effect on the life of the engine.

It is, therefore, most important that the work of removing the deposits of carbon is not neglected. This should be carried out as a matter of routine and not left until a fall off in power and performance makes it necessary.

## DECARBONISING THE EXHAUST SYSTEM.

At intervals of about 3,000 miles, or more frequently if the machine is used mainly for short runs, or stop and start riding, the deposits of carbon should be removed from the exhaust system.

Remove the exhaust pipe after unscrewing the large exhaust port nut and slackening the silencer clip. Scrape the carbon out of the pipe, using a suitable implement. Turn the piston to its lowest position and clean out the exhaust port, using a small scraper of a soft metal such as aluminium or copper to avoid scratching the soft material of the cylinder. Take care to keep the dislodged carbon out of the cylinder.

The silencer dismantles for cleaning. (See Fig. 10). Remove the

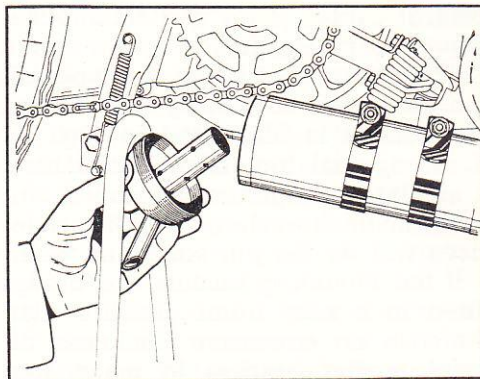


Fig. 10  
Dismantling silencer

two nuts from the central through-bolt and pull off the tail pipe assembly. Clean out the carbon from the inside of the silencer body making sure that the holes in the central baffle plate are clear. Now attend to the tail pipe assembly, taking care that the holes in the central tube and the tail pipe itself are unobstructed.

When replacing the exhaust pipe always fit a new exhaust port ring gasket.

## DECARBONISING THE ENGINE

First remove the engine as detailed on page 8. Take out the sparking plug. Unscrew the four cylinder head nuts and remove the washers. Draw off the cylinder head, taking care not to lift the cylinder in the process and thus break the joint between the cylinder and the crankcase.

For the actual work of removing the deposits of carbon a soft metal scraper should be used (copper, aluminium, etc.). Hold the cylinder and turn the flywheel to bring the piston to the top of its stroke. Scrape the carbon from the crown of the piston. If it has not already been done turn the flywheel until the piston is at the bottom of its stroke and clean out the carbon from the exhaust port. Scrape the carbon from the cylinder head combustion chamber.



## MOPED WORKSHOP MANUAL

Remove all traces of loose carbon from all the components, preferably with a jet of compressed air, or by blowing with a tyre pump. When refitting the cylinder head, use a new cylinder head gasket and tighten the cylinder head nuts alternately, a little at a time, to avoid any distortion. Clean and reset the sparking plug and refit it in the cylinder head. Refit the engine in reverse order to dismantling as described on page 9.

### DECOMPRESSOR VALVE

Should the decompressor valve require attention, the cylinder head will have to be removed. It is recommended, therefore, that the valve is serviced as a matter of routine when decarbonising the engine.

To remove the valve, cut off the head of the spring retaining pin and remove it, taking care not to let the component parts fly apart. Push out the valve. Examine the seating surfaces and if any pitting or burning is noticeable, grind in the valve, using a fine grinding paste. Wash off all traces of grinding paste with paraffin or petrol.

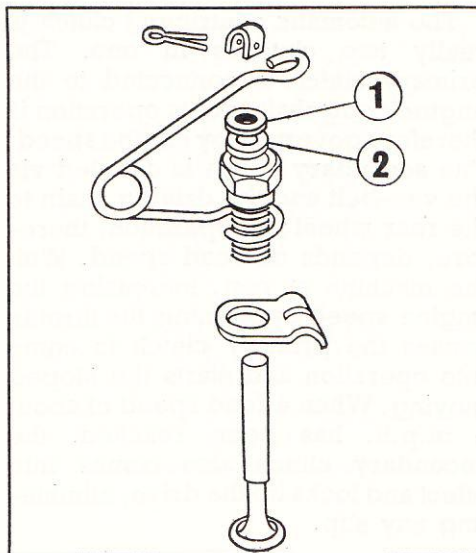


Fig. 11

1. Seal retaining washer
2. Decompressor valve seal

A plastic seal is fitted in the valve guide. If there is excessive leakage around the valve stem, the seal must be replaced. (See Fig. 11). A new spring retaining pin will be required when reassembling.

## AUTOMATIC CLUTCH AND VARIABLE GEAR UNIT

### Special Tools Available for Clutch Servicing

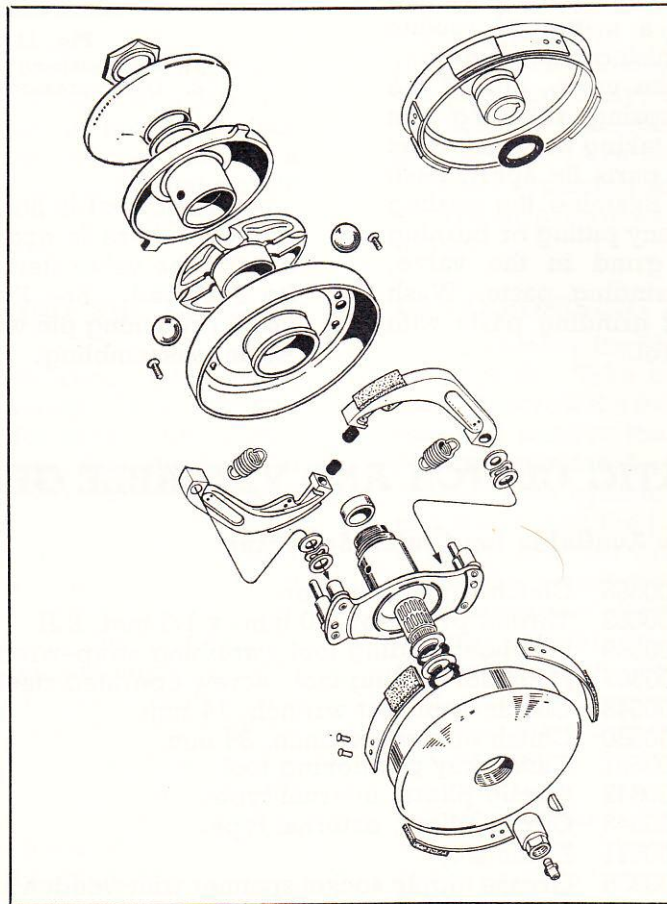
- 6200558 Clutch drum extractor.
- 6200562 Thread protector, 10 mm. x 1.0 mm. R.H.
- 6200569 Flywheel holding tool (webbing strap-wrench type).
- 6200567 Flywheel holding tool (screw operated steel band type).
- 6200548 Clutch drum nut wrench, 14 mm.
- 6200550 Clutch hub nut wrench, 35 mm.
- 6200561 Clutch key positioning tool.
- 6200542 Circlip pliers, internal type.
- 6200543 Circlip pliers, external type.
- 6200571 Piston stop.
- 6200555 Grease nipple socket spanner with wooden handle, 6 mm.
- 6200651 Magnetic extractor, clutch washer.
- 6200647 Clutch holding tool.

## MOPED WORKSHOP MANUAL

The automatic centrifugal clutch is really two clutches in one. The primary clutch is connected to the engine crankshaft and its operation is therefore governed by engine speed. The secondary clutch is coupled via the vee-belt and the driving chain to the rear wheel; its operation, therefore, depends on road speed. With the machine at rest, increasing the engine speed by opening the throttle causes the primary clutch to come into operation and starts the Moped moving. When a road speed of about 4 m.p.h. has been reached, the secondary clutch also comes into effect and locks up the drive, eliminating any slip.

When the twistgrip is turned to the neutral position and the speed of the Moped is brought below 4 m.p.h., the clutch drive disengages and the Moped can come to a standstill with the engine idling.

In addition, the variable transmission pulley, being responsive to road speed and also to the load on the engine, automatically selects the correct drive ratio for the particular road conditions. This improves the road performance of the machine and allows any but the very steepest of hills to be climbed without any help from the rider.



**Fig 12**  
Exploded view of clutch



## REMOVING CLUTCH DRUM

Prevent the crankshaft turning, preferably by holding the magneto flywheel with a strap wrench (See Fig. 13), or by using a piston stop screwed into the sparking plug aperture. Take out the central grease nipple (6 mm. spanner). Using a 14 mm. spanner, unscrew the clutch drum nut. Fit a thread protector on to the crankshaft thread and screw the clutch drum extractor fully into the hub. Tighten the extractor bolt. (See Fig. 14). If the drum is not loosened by means of reasonable pressure on the bolt, tap the head of the bolt with a hammer and re-tighten, repeating this sequence until the drum is free. Remove the extractor, unscrew the thread protector and take off the drum. Now remove the key from the shaft and put it in a safe place. Note that a plastic seal is fitted to the boss on the inside of the clutch drum. This can normally be left in position.

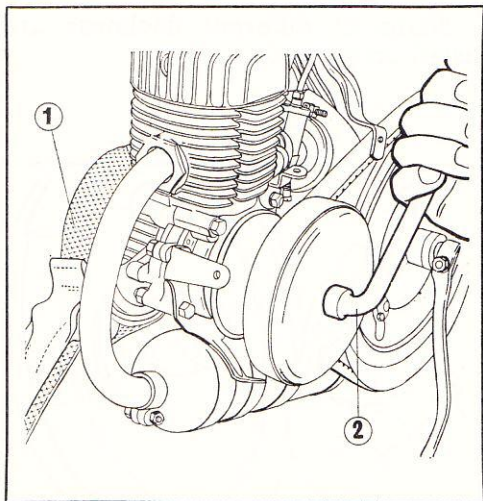


Fig. 13

Removing clutch drum nut

1. Strap wrench
2. 14 mm. spanner

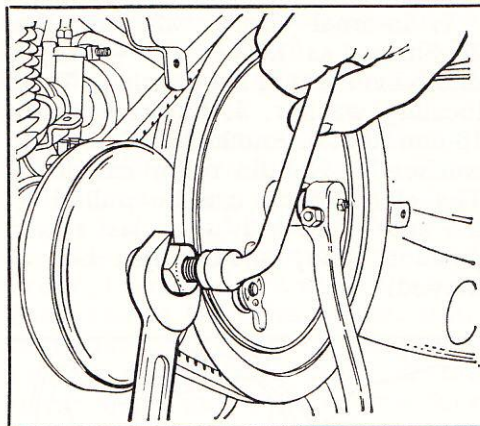


Fig. 14

Removing clutch drum

## REMOVING CLUTCH/GEAR BODY

The clutch body is located on the crankshaft by circlips. Extended nose circlip pliers are required to remove them. (See Fig. 15). The order of dismantling is as follows:—

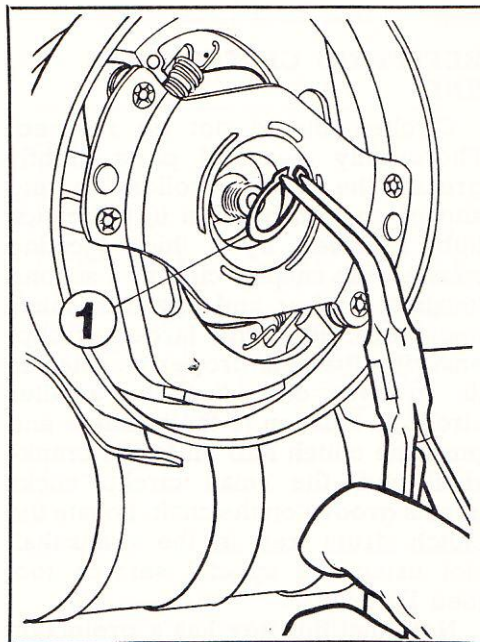
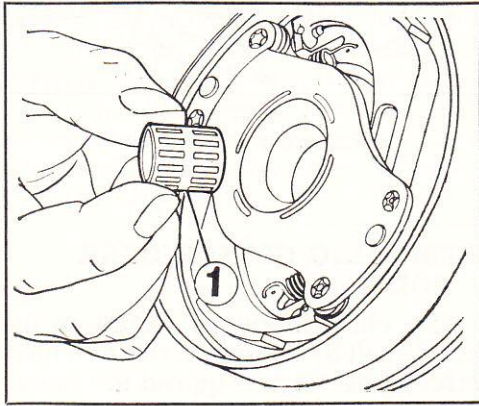


Fig. 15

1. Internal type circlip



1. Internal circlip, 22 mm. dia.  
 2. Shims, as necessary, to adjust end movement of the clutch. 3. Thick locating washer. 4. External circlip 15 mm. dia. 5. Another thick locating washer. 6. Needle roller cartridge. The clutch body can be pulled off the crankshaft with these last two in position. They should then be removed.

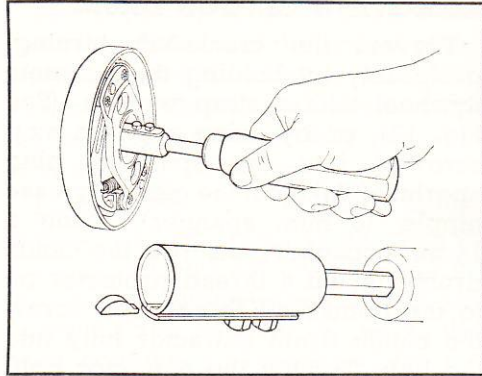


**Fig. 16**  
 1. Needle roller bearing

## REFITTING CLUTCH/GEAR UNIT

Circlips should not be re-used. Thoroughly clean all parts, lightly grease the needle roller bearing and place it in position in the clutch hub, followed by a thick locating washer, the smaller circlip, a second locating washer and any thin shims necessary. Refit the larger circlip, ensuring that it is properly seated in its groove, centralise the smaller circlip in relation to the washers and push the clutch hub on to the crankshaft until the small circlip clicks into its groove on the shaft. Locate the clutch drum key in the crankshaft slot using the special service tool (See Fig. 17).

Note that this key has a projection to prevent it being dislodged when fitting the drum. The key should be



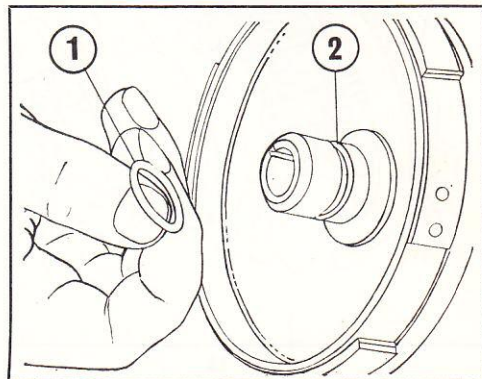
**Fig. 17**  
 Using clutch key positioning tool

fitted with the projection away from the crankcase.

Replace the clutch drum and lock-nut, ensuring that the plastic seal is correctly fitted in its groove on the centre boss of the drum. (See Fig. 18). Refit the grease nipple.

The clutch body should have approximately 0.004" end float on the crankshaft. To adjust this, remove from or add to the shims behind the large circlip.

Shims of different thickness are listed on page 52.



**Fig. 18**  
 1. Clutch drum seal  
 2. Seal groove

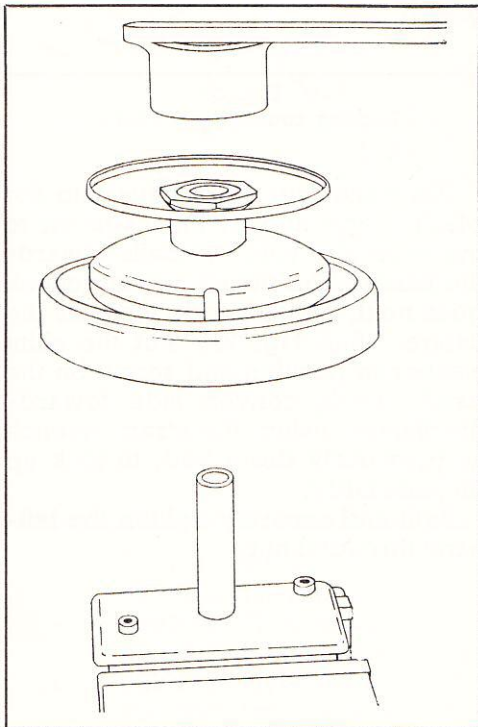


## RELINING CLUTCH DRUM

Remove the drum as detailed above. File or grind off the rivet heads on the outside of the drum and tap out the rivets with a pin punch. Take note of which way the leaf springs were fitted and fit the new ones in the same manner. Care must be taken when removing or fitting rivets that the drum is properly supported to prevent distortion. After the rivetting operation, the drum should be placed in a lathe and the rivet heads machined level with the inside surface of the drum.

## DISMANTLING CLUTCH/GEAR BODY

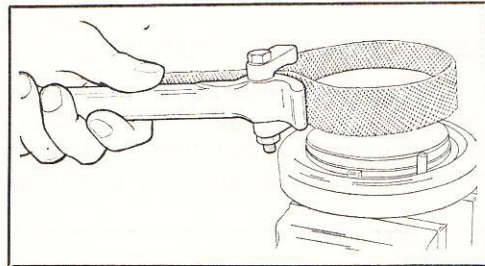
Remove the clutch from the crankshaft. Lift out the locating washer and needle bearing from the clutch hub. Put the special clutch



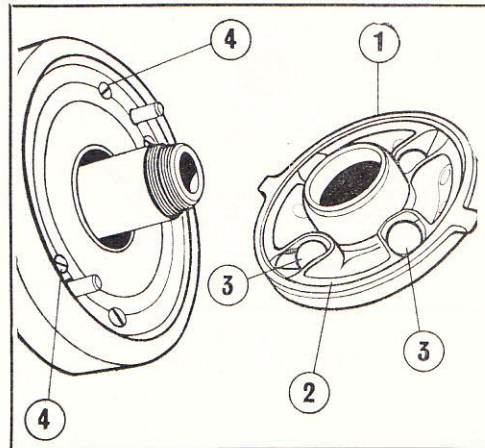
**Fig. 19**  
Using clutch holding tool

holding tool in the vice and place the clutch, shoes down, over it with the clutch centre over the central pin. (See Fig. 19).

Unscrew the large nut (left-hand thread) from the centre of the fixed pulley cheek, using a 35 mm. spanner. Unscrew the fixed pulley cheek from the rest of the unit (right-hand thread) by means of a strap wrench. Now remove the shim washer from the pulley centre. Lift off the pulley moving cheek, also take off the plastic cage and remove the four steel balls.



**Fig. 20**  
Removing pulley fixed cheek



**Fig. 21**  
Assembly of variable gear

1. Pulley moving cheek
2. Plastic cage
3. Steel balls
4. Countersunk screws

# MOPED WORKSHOP MANUAL

The next task is to release the four countersunk screws at the rear of the clutch flange. A portion of the edge of each of these screws is pressed into a recess in the flange in order to prevent the screws from coming loose in service. A properly ground screwdriver of the correct size will, however, free them without difficulty. Remove the flange from the hub. Lift off the shoes and springs as a unit, noting that beneath each shoe on the pivot, are fitted one plain washer, one curved washer and one plain (with the smaller internal diameter), in that order.

## REASSEMBLING CLUTCH

Thoroughly clean all the parts. Fit the shoes, not forgetting the washers, and also noting that two holes are provided in each shoe in order to

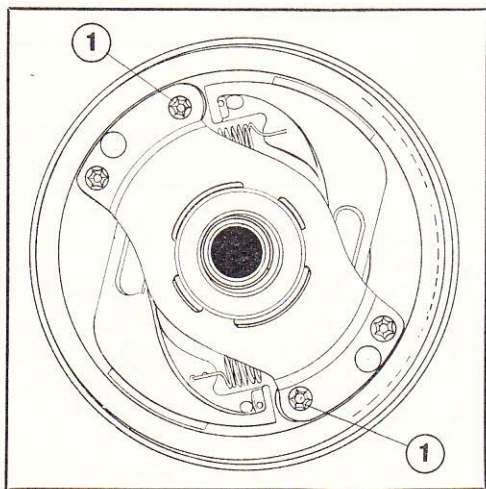


Fig. 22

1. Clutch shoe pivot pins

vary the spring tension. The end of the spring is normally fitted in the hole nearest the lining. It is essential for the clutch shoes to be fitted the correct way round. (See Fig. 22). Replace the flange on the hub, with the drive pegs through the centre pair of the six outer holes. Use new screws and tighten them into the hub through the four countersunk holes in the flange. Lock each screw into position by tapping over an edge into the special recess in the flange. (See Fig. 23).

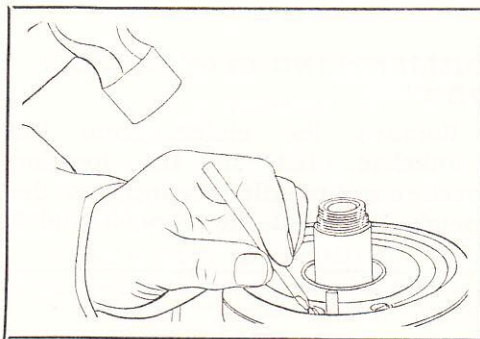


Fig. 23

Locking countersunk screws

Place the four steel balls into the plastic cage and fit the cage on to the assembly with the balls towards the flange. The pulley moving cheek goes next, concave side towards the flange. (See Fig. 21). Put the shim washer in position and screw on the fixed cheek, convex side towards the flange, using the strap wrench as previously described, to lock up the assembly.

Refit and securely tighten the left-hand threaded nut.



FLYWHEEL MAGNETO

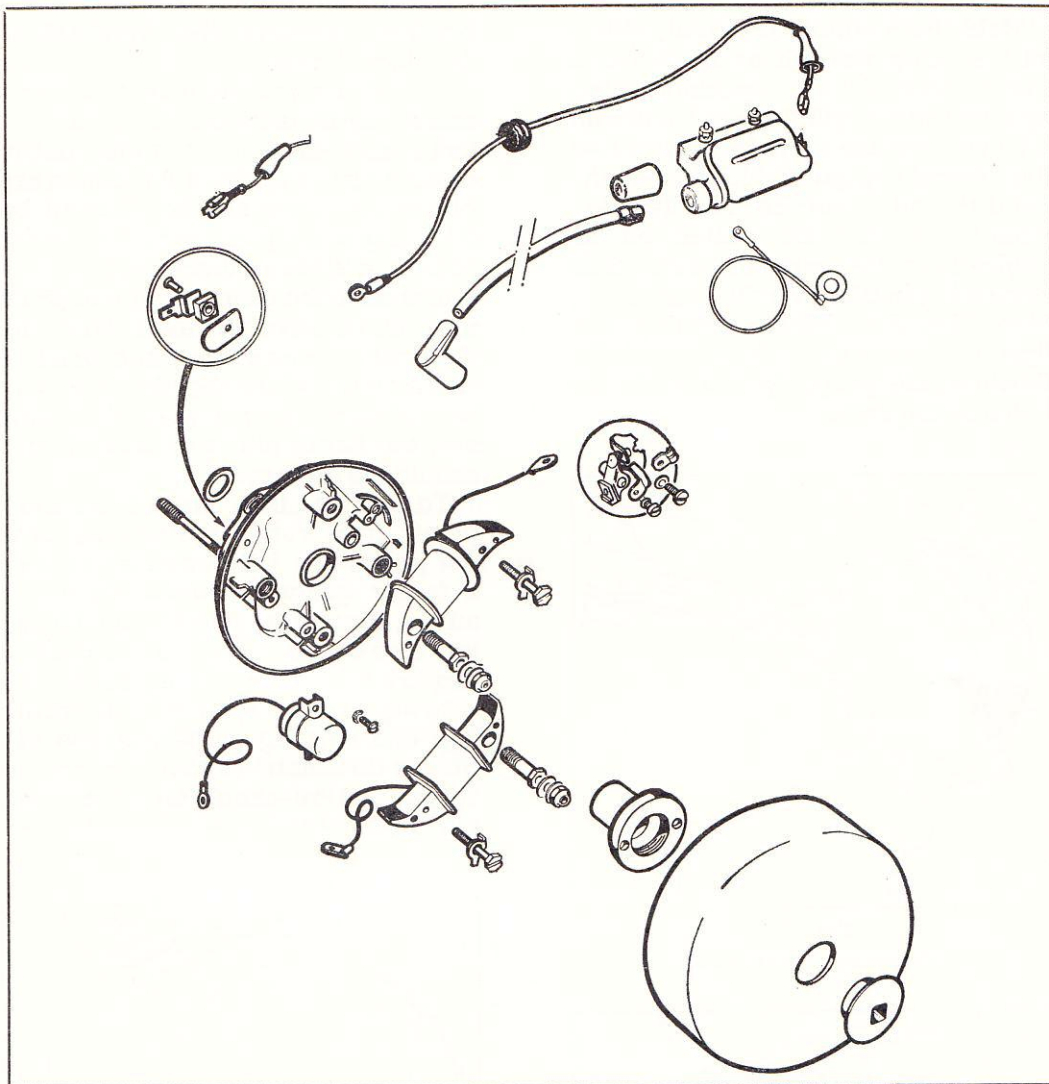


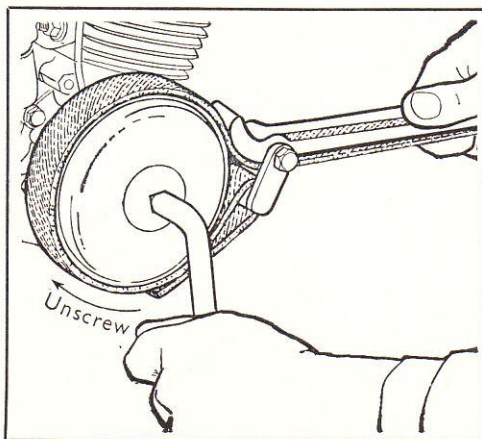
Fig. 24  
Exploded view of magneto

**Special Tools Available for Magneto Servicing**

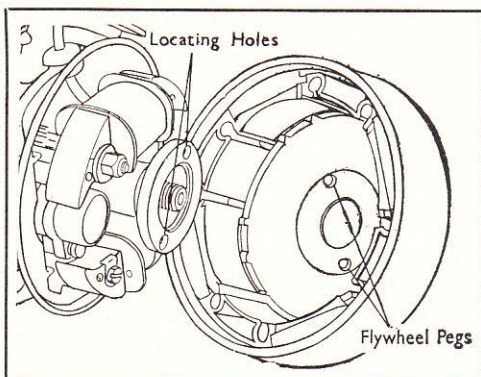
- 6200557 Magneto flywheel hub/cam extractor.
- 6200563 Thread protector, 10 mm. x 1.0 mm. L.H.
- 6200565 Flywheel nut key, 10 mm. square.
- 6200569 Flywheel holding tool (webbing strap wrench type).
- or 6200567 Flywheel holding tool (screw operated steel band type).
- 6200556 Ignition advance gauge.
- 6200571 Piston stop.
- 6200346 Coil centralising ring.

## REMOVING AND REPLACING FLYWHEEL

Hold the magneto flywheel, either with a strap wrench or by fitting a piston stop in the sparking plug aperture in the cylinder head, and with a 10 mm. square ended key unscrew the central cap nut, which has a left-hand thread. (See Fig. 25). The flywheel can then be pulled off its register on the cam, the cam itself remaining in place on the crankshaft. (See Fig. 26). When refitting the flywheel, ensure that the pegs on the flywheel are properly located in the holes in the cam.



**Fig. 25**  
Removing flywheel nut



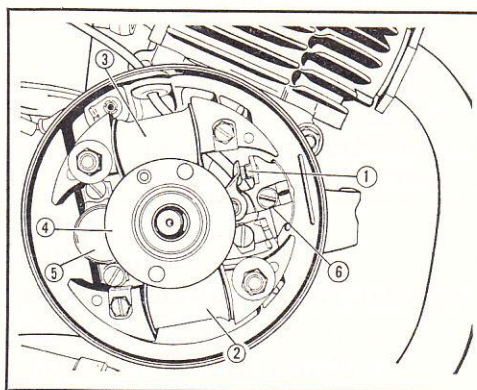
**Fig. 26**  
Removing flywheel

## CONTACT BREAKER POINTS

To obtain access to the contact breaker, remove the flywheel as detailed above.

Check the condition of the points and if oily or dirty clean with a non-fluffy rag dipped in pure petrol or methylated spirit. If the points are blackened, they can be cleaned by inserting a strip of very fine glass paper between them. Close the points on to the glass paper and draw it through several times with the abrasive side towards each point in turn. Points that are slightly pitted may be refaced using a special contact file, but badly pitted or worn points should be replaced.

To check the contact breaker points gap, rotate the engine until the points are fully open and insert a feeler gauge between them. To adjust, loosen the fixed contact locking screw and move the contact as required by inserting the blade of a screwdriver into the slot in the spring clip and twisting slightly in the required direction. Tighten the locking screw and re-check the gap. (See Fig. 27).



**Fig. 27**

1. Contact breaker points
2. Ignition low tension coil
3. Lighting coil
4. Cam
5. Condenser
6. Fixed contact locking screw



## REPLACING CONTACT BREAKER

Remove the screw and washer and take off the three leads from the insulated terminal. Loosen the fixed contact locking screw and remove it, together with the spring clip. Take out the contact breaker. Ensure that the new contact breaker is perfectly clean and place it in position, locating the spindle peg in the drilled boss in the stator plate.

Re-connect the three leads to the insulated terminal and fit the fixed contact locking screw, washer and spring clip. Make sure that none of the three leads is trapped between the contact breaker and stator plate and adjust the points gap to 0.016" —0.018".

## MAGNETO TIMING

It should not be necessary to disturb the initial setting of the cam but if for any reason the cam has to be removed, the special extractor should be used, in conjunction with a crankshaft thread protector. (See Fig. 28).

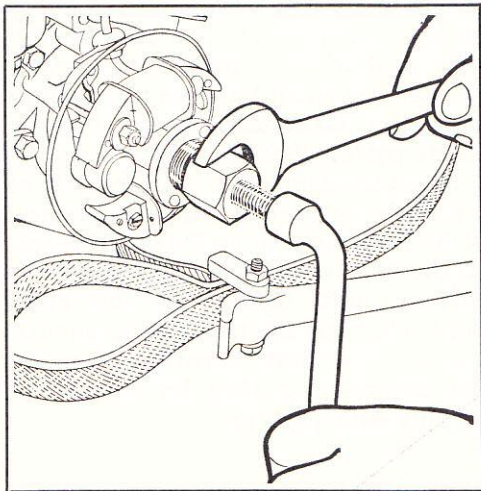


Fig. 28  
Removing flywheel cam

Screw the body of the extractor fully home and tighten the central screw **WITHOUT USING UNDUE FORCE**. With a hammer, give the end of the screw a sharp tap, which should free the cam from the shaft. If not, repeat the process.

To re-time the ignition when replacing the cam, take out the sparking plug and screw in its place the ignition advance gauge. Provisionally replace the cam and turn it until the contact breaker points

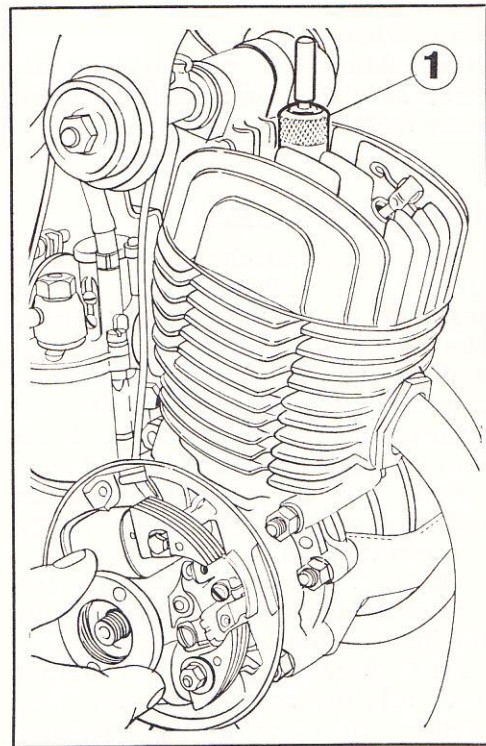


Fig. 29  
1. Ignition advance gauge

are fully open. Check the points gap and, if necessary, adjust it to 0.016" —0.018". Remove the cam. Rotate the engine and, as it turns, the plunger in the centre of the tool will rise until at top dead centre it reaches its highest point. (See Fig. 29). Turn



the engine back until the plunger has fallen by  $\frac{1}{16}$ " (.063") and keeping the engine from turning any further, replace the cam in such a position that the points are just beginning to open. Give the cam a sharp tap with a wooden implement to fix it on the taper and refit the flywheel.

## REPLACING CONDENSER

Remove the two condenser fixing screws and washers and disconnect the condenser lead from the contact breaker insulated terminal. Remove the condenser.

When fitting the new condenser, make sure that the lead is run well away from the moving parts.

## REPLACING COILS

Each coil is attached to the stator plate by a hollow screw and a hexagon screw with slotted head. The stator plate itself fits over two studs which project from the crankcase and protrude through the two hollow screws. Washers are fitted over the ends of these studs and self-locking nuts screw on to the studs and clamp the stator plate firmly to the crankcase.

The L.T. ignition coil can be removed as follows, without disturbing the ignition timing.

First disconnect the coil output lead from the contact breaker connection. Unscrew the self-locking nut (8 mm. spanner) and remove the washers from beneath it. The slotted hexagon screw is locked in place by a tab washer with the tab turned over one flat of the screw. Flatten out the tab washer and remove this screw. Take out the hollow screw and remove the coil from the stator plate.

The lighting coil can be removed in a similar manner, but due to the

rivetting of the output lead to the terminal on the stator plate, it is usually more convenient to remove the whole stator plate from the machine. The lead can then either be unsoldered from the terminal, or the terminal rivet drilled out, in which case a new terminal will be required when refitting.

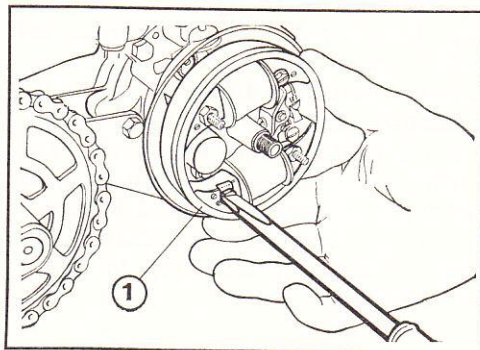


Fig. 30

1. Coil centralising ring

When replacing coils, it is essential that they should be fitted correctly, in order to provide a constant minimum clearance between their pole pieces and the flywheel. A coil centralising ring must be used to position them accurately.

The coils are assembled loosely on the stator plate, the centralising ring pushed over them and located on the four small tongues protruding from the threaded bosses on the stator plate. (See Fig. 30).

Press the laminated pole pieces of the coils against the inside surface of the ring and tighten the coil screws. Fit the two self-locking nuts and their washers and tighten up the nuts. Fold over the tab washers to secure the two slotted screws. Remove the centralising ring by turning it slightly and pulling.

## REMOVING STATOR PLATE

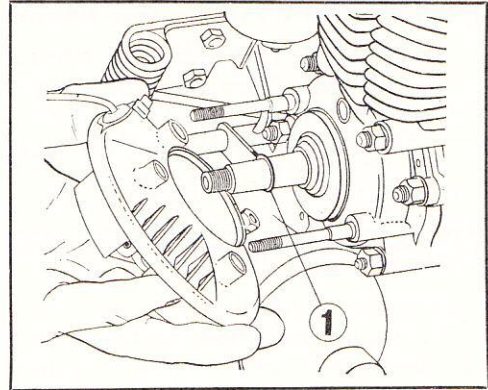
Remove the cam. Unscrew the two



self-locking nuts on the coil pole pieces (8 mm. spanner) and take off the washers. Disconnect the wire from the lighting terminal at the rear of the stator plate. Disconnect also the L.T. ignition wire from the external ignition coil and pull the wire clear of the frame.

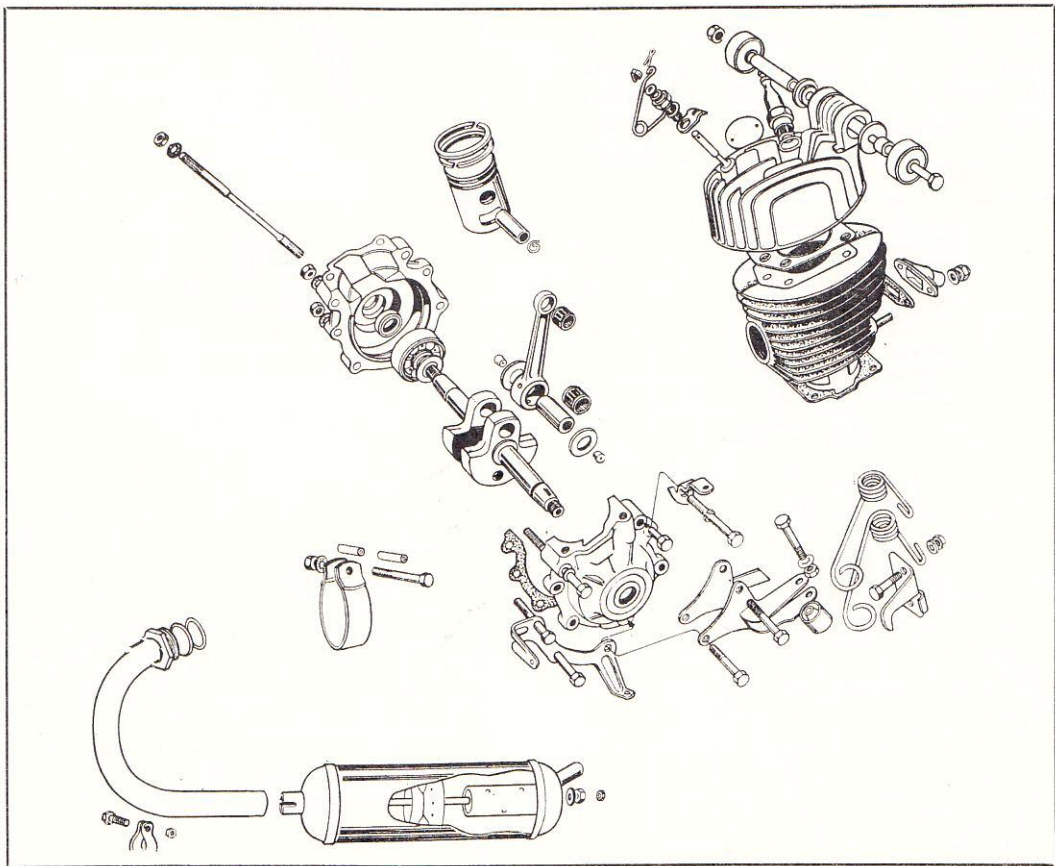
The stator plate will now pull off the mounting studs. Take care not to lose the small sealing ring fitted to the crankshaft behind the stator plate. (See Fig. 31).

Refit in reverse order to dismantling.



**Fig. 31**  
1. Sealing ring.

## DISMANTLING AND REASSEMBLING ENGINE UNIT



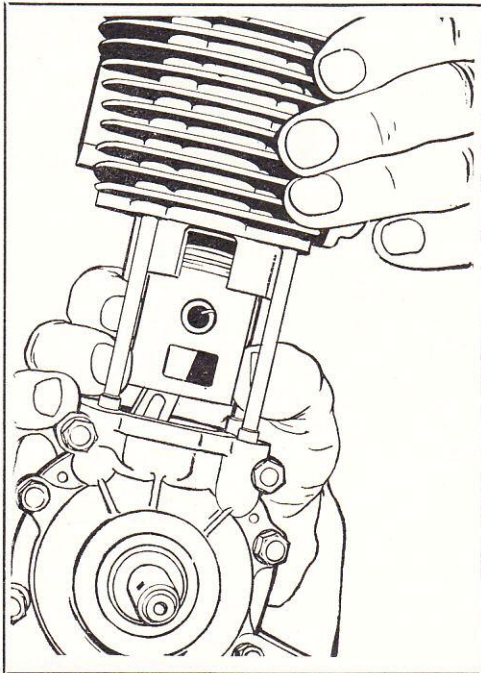
**Fig. 32**  
Exploded view of engine.

## Special Tools Available for Engine Servicing

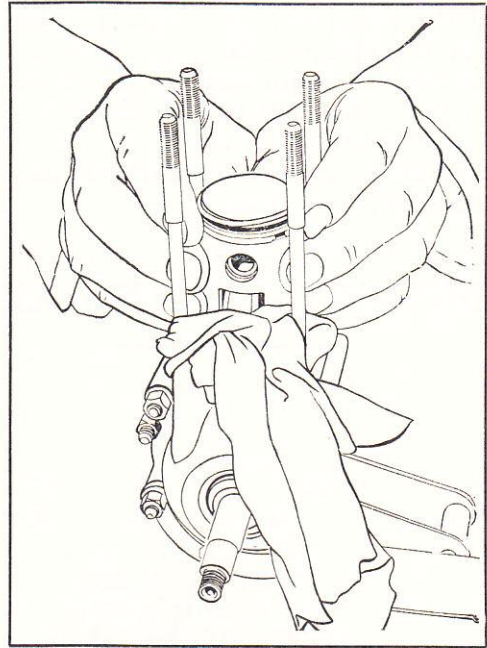
- 6200559 Gudgeon pin extractor and fitting tool.
- 6200566 Crankshaft bearing extractor.
- 6200654 Dummy bearings.
- or 6200652 Crankcase/crankshaft gauge.
- 6200560 Piston ring clamp.

## DISMANTLING CYLINDER AND PISTON

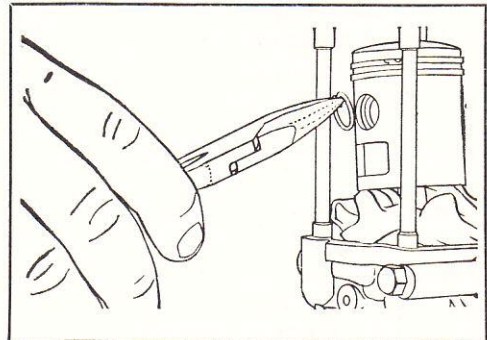
Remove the engine from the frame and remove the clutch and magneto as described in the appropriate sections. Take out the stator plate mounting studs. Unscrew the sparking plug and detach the cylinder head. The cylinder barrel can now be lifted off (See Fig. 33), but take care not to impose any side loads, which may bend the connecting rod. Remove the piston rings (See Fig. 34). Take out the gudgeon pin circlips (See Fig. 35) and after evenly warming the piston to approximately 250°F., press out the gudgeon



**Fig. 33.**  
Removing cylinder barrel



**Fig. 34**  
Removing piston rings

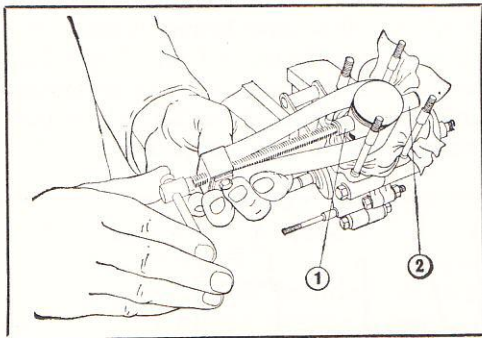


**Fig. 35**  
Removing gudgeon pin circlips

pin with the special gudgeon pin tool. (See Fig. 36). It is essential that



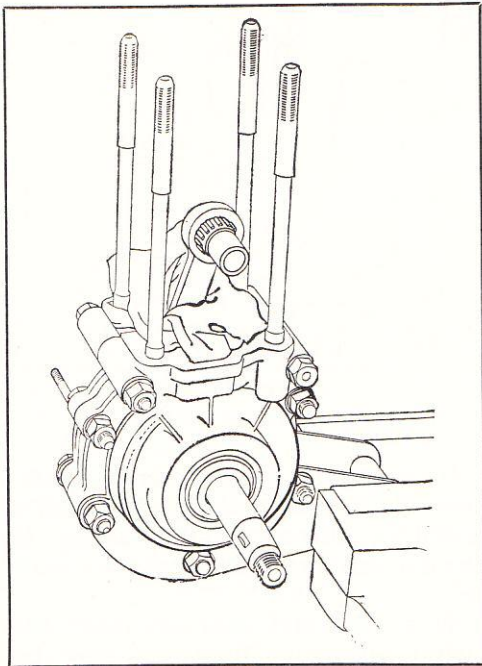
the correct tool is used for this operation in order to prevent damage to the small end needle roller bearing. Remove the tool from the piston and push out the pilot drift with the fingers. The piston is now free. Remove the needle roller bearing to a safe place.



**Fig. 36**

Pressing out gudgeon pin

1. Pilot drift
2. Gudgeon pin

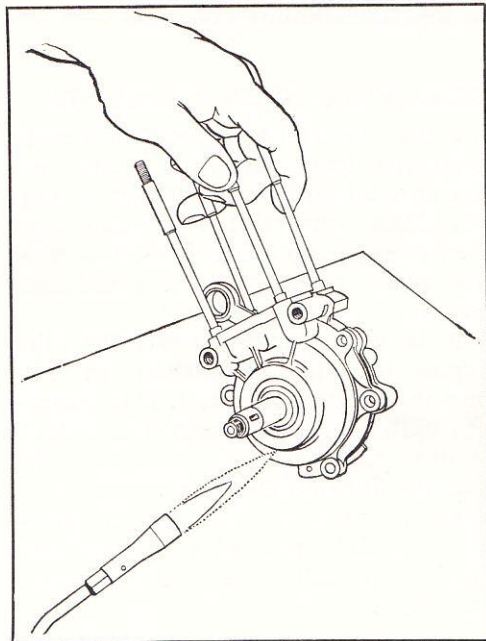


**Fig. 37**

Small end assembly, less piston

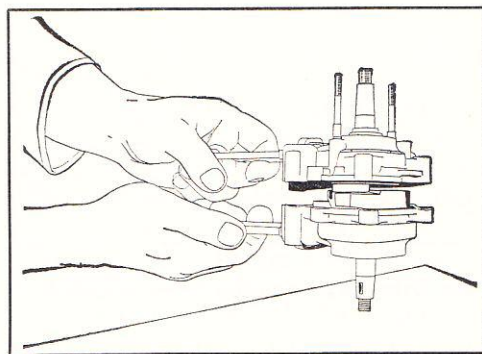
## DISMANTLING CRANKCASE

Take out the seven bolts which hold the crankcase together and remove the engine plates. Note that the bolt which is threaded into the crankcase at the top rear has a coarser thread than the others. To free the crankcase from the main bearings it will be necessary to heat



**Fig. 38**

Heating crankcase



**Fig. 39**

Splitting crankcase

the crankcase to about 250°F. If a direct source of heat is used, i.e. a blow lamp or gas flame (See Fig. 38) care must be taken to ensure that the case is heated evenly. Tap the ends of the crankshaft on a wooden bench to free the crankcase halves. (See Fig. 39)

Prise out the crankcase oil seals and throw them away, since they will have been damaged by the heat of the dismantling operation.

## REMOVING MAIN BEARINGS

If it is desired to remove the main bearings from the crankshaft, use the special tool as illustrated in Fig. 40. Take note of the position and thickness of any shims fitted between the main bearings and crankshaft webs.

It is not recommended that the repair of the crankshaft or big end should be attempted. This operation calls for special equipment which is normally possessed only by the Factory Service Department. An exchange crankshaft scheme is in operation which provides guaranteed Factory Rebuilt Units at an economical price.

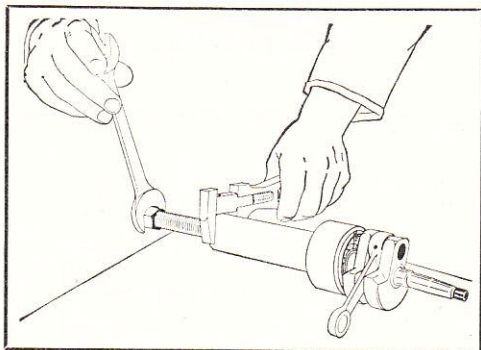


Fig. 40

Removing main bearing from crankshaft

## REASSEMBLING CRANKCASE

If a new or replacement crankshaft

is to be fitted, the end-float of the shaft must be checked and adjusted if necessary. The most convenient way of doing this is to obtain a pair of dummy bearings, which are a sliding fit on the shaft and in the crankcase, but are of the exact width of the orthodox bearings. These are obtainable from our Spare Parts Department. Mount the crankshaft in the crankcase using the dummy bearings and fit shims between the crankwebs and bearings until the required end-float is obtained, i.e. 0.004" approx.

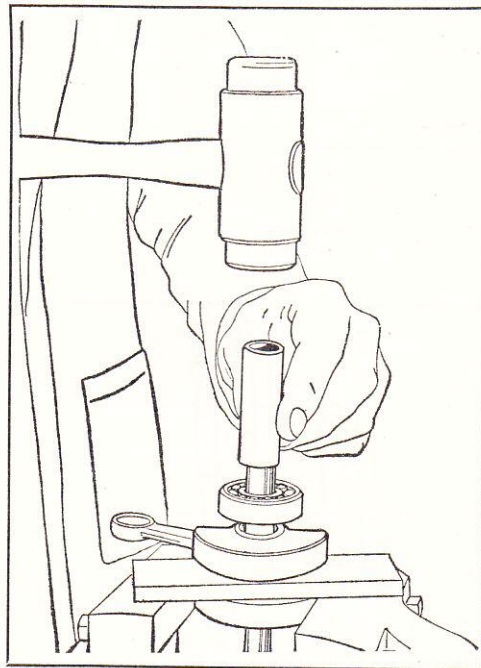


Fig. 41.

Fitting a main bearing

Do not forget to allow for the thickness of the crankcase gasket, and if possible, distribute the shims to ensure an even thickness at each side.

When the end-float has been adjusted the main bearings may be assembled onto the crankshaft, in the following manner :-



Place a piece of metal  $\frac{5}{16}$ " thick between the crankwebs and support the metal on a vice as shown in Fig. 41. Check that the correct shims are in place and use a piece of tube of about  $\frac{5}{8}$ " inside diameter to drive the bearings onto the shaft. Force should only be applied to the inner race of the bearing.

Slide new oil seals onto the crankshaft making sure that the "lips" of the seals are outwards, away from the crankwebs. Take care not to damage the seal. Apply clean oil to the main and big end bearings. Warm up one half of the crankcase to about 250°F. and fit the crankshaft as quickly as possible. (Make sure it is the correct way round). Place a new crankcase gasket in position on this half, held by a little grease if necessary, warm up the second half of the crankcase and fit the two halves together.

Do not forget the lower engine mounting plates when putting in the crankcase bolts. Tighten up the bolts evenly a little at a time. Do not over tighten.

## PISTON SIZES

Before proceeding with the assembly of the piston onto the connecting rod, a few words are called for on the subject of piston sizes. To achieve the long life for which these engines are noted, very close tolerances are employed when fitting the piston to the cylinder. It would be very uneconomical to manufacture pistons and cylinders to such fine limits as to make them all interchangeable; therefore, each piston is exactly matched to the correct cylinder at the Factory. If a replacement piston only is required, it is necessary for the cylinder to be returned to the factory where it will be measured and fitted with a new piston of the correct size.

## REFITTING PISTON

Continuing the assembly of the engine unit, oil the small end needle roller bearing and place it in position in the connecting rod eye. Then place the piston in position, making sure it is the right way round, i.e. that the small square cutaway in the skirt is to the front. Insert the long pilot drift of the gudgeon pin tool as a temporary gudgeon pin to align the assembly. Warm the piston and press in the gudgeon pin with the special tool, at the same time pushing out the temporary pin, thereby maintaining the alignment and preventing damage to the bearing. (See Fig. 42). Fit new circlips ensuring that they are properly located in their grooves.

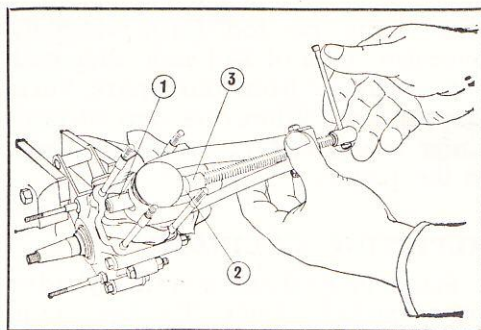


Fig. 42

Refitting gudgeon pin

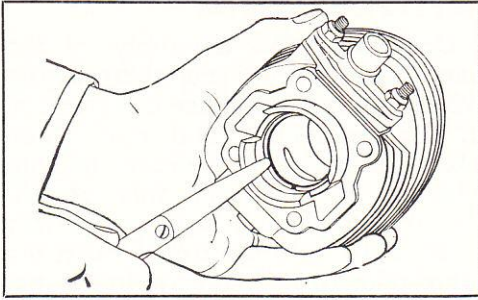
1. Long pilot drift
2. Gudgeon pin
3. Short pilot drift

## PISTON RINGS

Before refitting the piston rings the gaps must be checked and adjusted, if necessary, to the clearance shown in the Technical Data, by the following method.

Place the piston ring in the cylinder bore and ensure that it is absolutely square to the axis of the cylinder by pushing it half an inch or so down the bore with the piston. Check the gap between the ends of the piston





**Fig. 43**  
Checking piston ring gap

ring with feeler gauges. (See Fig. 43). If the gap is too small, file the ends of the ring carefully and re-check.

If the gap is too large, new piston rings must be fitted, not forgetting, of course, to check the gap of the new rings. Should the gap of even new rings be too large, slightly oversize rings of 39.1 mm. diameter are available from our Spare Parts Department. When the gap of both rings is satisfactory, refit the rings to the piston.

## REFITTING CYLINDER

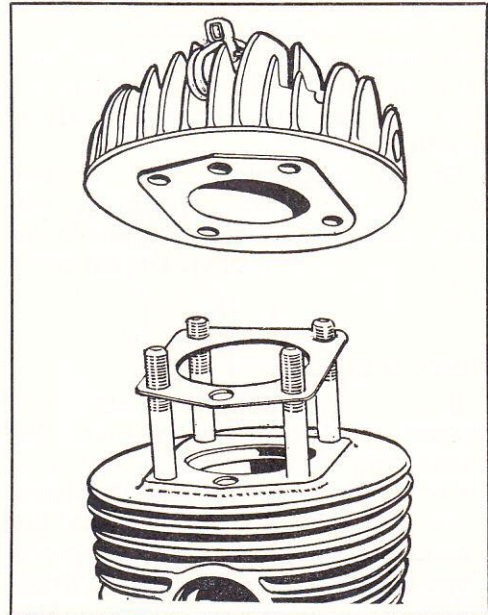
Place in position a new cylinder base gasket, check that the rings are located in relation to the pegs, oil and refit the cylinder. A piston ring clamp is available, if required, to facilitate this operation.

When the cylinder is in position, check that the piston does not protrude above the top face of the cylinder, at "top dead centre". The edge of the piston must be level

with the top face of the cylinder and shims are available to fit beneath the cylinder to adjust the height, if necessary.

Replace the cylinder head, using a new gasket. Ensure that the hole in the gasket for the decompressor outlet is in line with the holes in the cylinder and head. (See Fig. 44). Tighten the cylinder head nuts evenly a little at a time in order to prevent distortion.

The clutch and magneto may now be replaced and the engine refitted to the frame as described in the appropriate sections.



**Fig. 44**  
Refitting cylinder head and gasket

## FUEL SYSTEM

### REMOVING CARBURETTOR

Take off both engine fairings, ensure that the fuel tap is in the "OFF" position, i.e. screwed down.

Unscrew the cap nut on the top of the float chamber and take off the banjo union, taking care not to damage or lose the fuel filter or the fibre



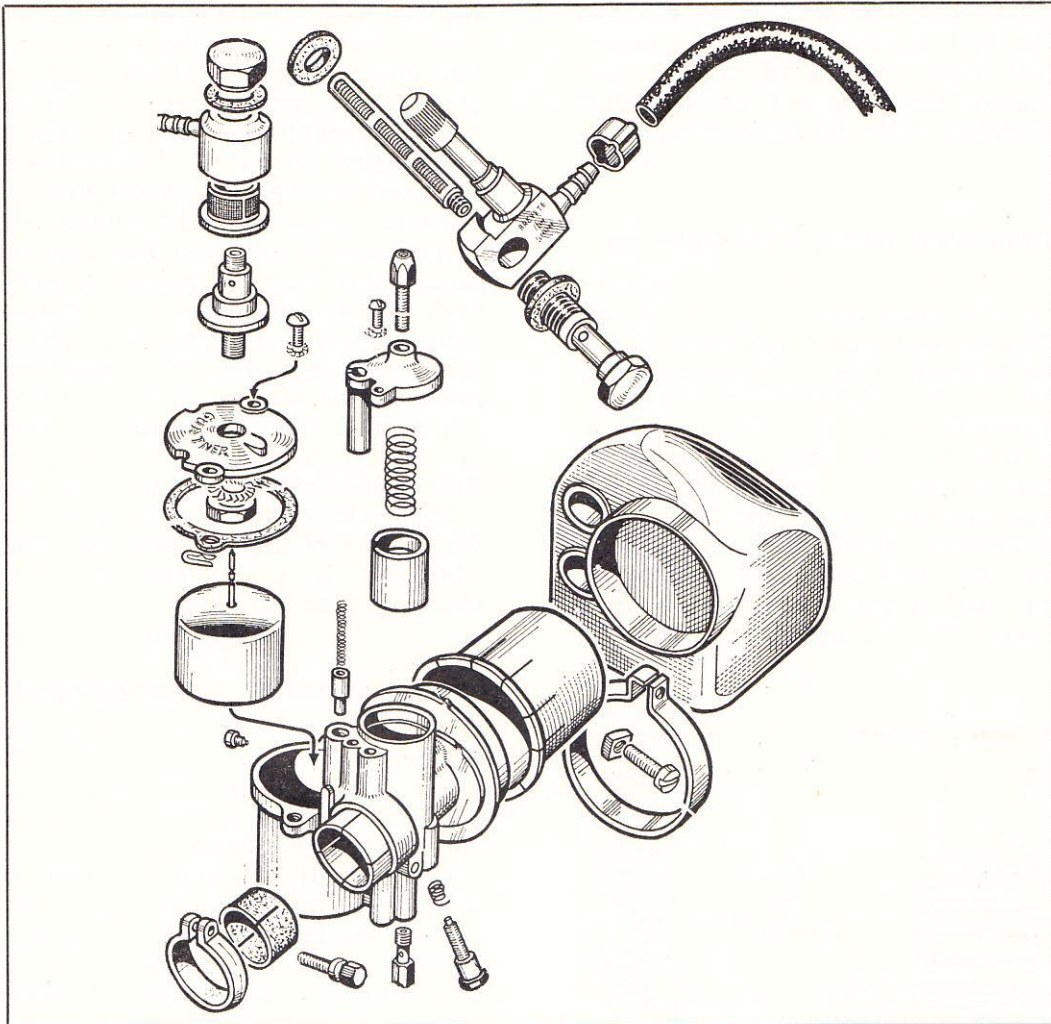


Fig. 45

Exploded view of carburettor

washer. Loosen the carburettor stub clamping ring and tilt the top of the carburettor towards the left side of the machine, to allow easy access to the screw which retains the mixing chamber cover. (See Fig. 3). Remove the mixing chamber cover screw and carefully lift off the cover, together with the throttle and enrichment valves. The carburettor may now be taken off the inlet stub and removed from the machine.

### REFITTING CARBURETTOR

Push the carburettor on to the inlet stub and replace the mixing chamber cover and the throttle and enrichment valves. The slot in the throttle valve body must engage with the spigotted guide screw in the carburettor body. (See Fig. 4). Tighten the mixing chamber cover screw, make sure the carburettor body is vertical and tighten the screw

of the stub clamping ring. Replace the fuel filter gauze, banjo union, fuel pipe and fibre washer and tighten the cap nut on the float chamber. Refit the fairings.

## DISMANTLING CARBURETTOR

Remove the carburettor as previously described. Loosen the air cleaner clip screw and take off the air cleaner. The air cleaner sleeve with the filter element may be withdrawn from the air cleaner body to enable the element to be washed. Take out the two screws and spring washers which retain the float chamber cover, lift off the cover and take out the float and float needle. If the gasket for the float chamber cover is damaged, it must be

replaced. Inspection of the float needle will reveal three grooves into one of which is fitted a spring clip. These grooves are to provide an adjustment for the level of the fuel in the float chamber. The correct fuel level is set at the Factory, and on no account should it be altered. If there is any doubt about the position of the clip, use the bottom groove first, which will give the lowest fuel level. The float may be fitted either way up, but of course the needle must always have the point uppermost. The float needle seat in the top of the float chamber is detachable, should the need arise.

The carburettor jet is screwed into the bottom of the carburettor, from where it is easily removed for cleaning (See Fig. 46).

## REASSEMBLING CARBURETTOR

All components should be thoroughly cleaned in petrol and dried with compressed air, if possible. Ensure that all drillings and jets are absolutely clean.

Replace the float and float needle (point uppermost) in the float chamber. Fit the float chamber cover and gasket, ensuring that the point of the float needle is located in its seat. Screw in the carburettor jet. Assemble and refit the air cleaner and refit the carburettor to the machine.

## CARBURETTOR ADJUSTMENT

The only adjustment normally required on this carburettor is the throttle stop screw, which controls the "tick-over" speed of the engine. This should be set at the point where the engine runs at the lowest speed possible consistent with reliability. Screwing in the throttle stop screw (2, Fig. 46) increases the "tick-over"

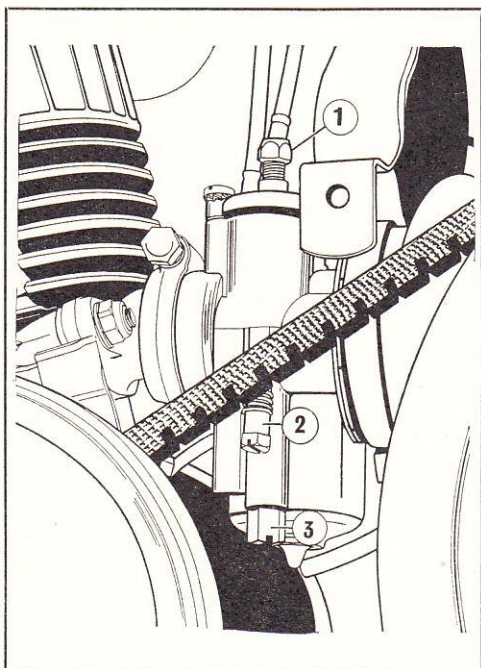


Fig. 46

1. Throttle cable adjuster
2. Throttle stop screw
3. Carburettor jet



speed, whilst unscrewing it will decrease the speed.

Mixture strength at speeds above "tick-over" is controlled by the main jet. In the unlikely event of adjustment being required to the mixture, alternative sizes of main jet are available, i.e. No. 24 and No. 26; No. 25 being the standard size. The No. 24 jet provides a weaker mixture and the No. 26 a richer mixture. Before any alteration is made to the jet sizes, it must be ascertained that

the fault does not lie elsewhere; for example, a damaged float and/or needle, a tilted carburettor, blocked drillways, or air leaks caused by poor joints, will all effect mixture strength.

## FUEL TAP

An additional fuel filter is fitted to the fuel tap mounting bolt. To clean this filter, drain the fuel tank and screw out the mounting bolt.

## TRANSMISSION - SERVICING

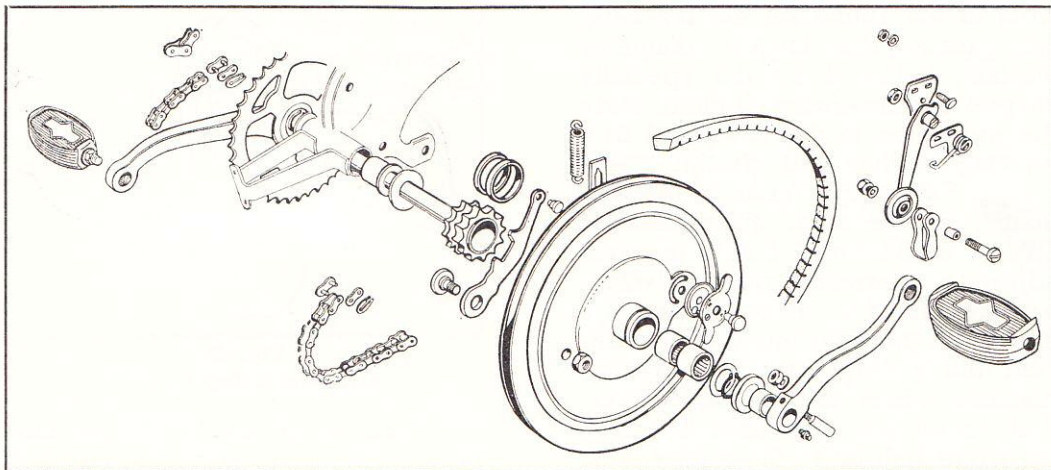


Fig. 47

Exploded view of bottom bracket axle assembly

## REMOVING BOTTOM BRACKET PULLEY AND AXLE

Detach both fairings and the clutch guard. Remove the rear chainguard and the outer chaincase and take off both chains. Pull the engine rearwards against the tensioning spring and take off the belt.

Remove the right-hand crank cotter pin and take off the crank and chainwheel. After the circlip and washer on the right-hand side of the axle have been removed, the crank

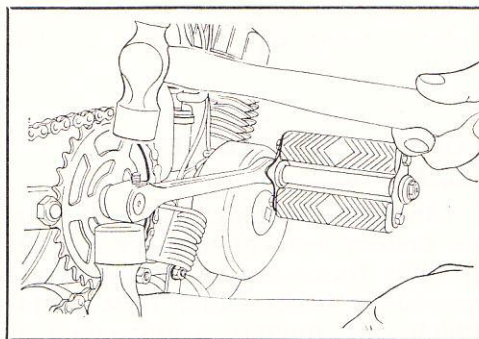


Fig. 48

Removing crank cotter pin



axle may be pulled out from its bearings together with the pulley assembly and sprocket. Take particular note of the positions and sizes of the packing washers. They will need to be replaced in their correct positions in order to maintain the required degree of "end float" on the shaft.

## REFITTING BOTTOM BRACKET PULLEY AND AXLE

Insert the axle in the frame, with the end that is drilled and tapped for the grease nipple to the left-hand side. Fit a packing washer and circlip to the right-hand end of the axle. Next to the frame on the left-hand side place the largest diameter washer, followed by the specially shaped middle circlip, if fitted. Slide the pulley on to the axle, and fit a packing washer and circlip. There should be a slight amount of "end float" on the axle, approximately 0.004". If the "end float" requires adjusting, alternative packing washers are available, as listed on page 52. When the adjustment is correct, refit the pulley hub cap, tubular distance piece and pedal cranks. Pull the engine rearwards and loop the drive belt on to the pulley, refit both chains, the chaincase and the clutch guard. Replace the fairings. Ensure that the pulley needle roller bearings are adequately lubricated before using the machine on the road.

## BOTTOM BRACKET AXLE BEARINGS

The plain bearings which support the bottom bracket axle are a press fit in the frame and are made from a special self-lubricating material for which no routine maintenance is required. If occasion arises to replace these bearings, the new ones must

be reamed to size (16 mm.) after being pressed into the frame.

## DISMANTLING BOTTOM BRACKET PULLEY

Continue the dismantling operation as follows:—Remove the left-hand cotter pin and crank. Slide off the distance tube from the crank axle and pull off the cap, which is lightly pressed onto the pulley hub. (See Fig. 49). Remove the circlip and washer and then the pulley assembly complete can be taken from the axle.

Certain models have a circlip fitted on the axle behind the pulley.

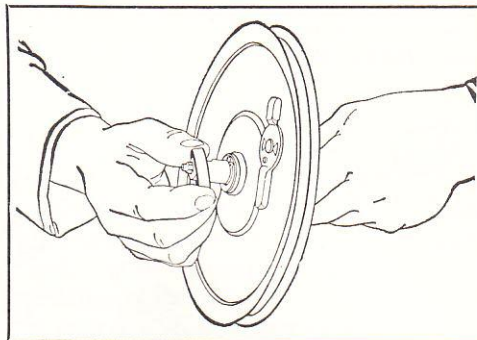
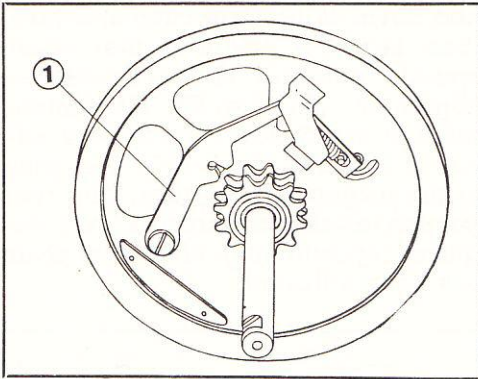


Fig. 49  
Removing pulley hub cap

The drive sprocket is a free running fit on the pulley hub, retained in position by the large washer which is fitted to the bottom bracket axle between the frame and the pulley. The sprocket may be either of two types, reversible or non-reversible, easily differentiated by the fact that the drive chain will fit either set of teeth on the reversible sprocket, but only one set on the non-reversible. The non-reversible sprocket can, therefore, only be fitted one way, i.e. with the wider teeth towards the pulley.

To transmit the drive from the pulley to the sprocket, a locking lever is employed, operated by a turn button on the outside of the pulley.

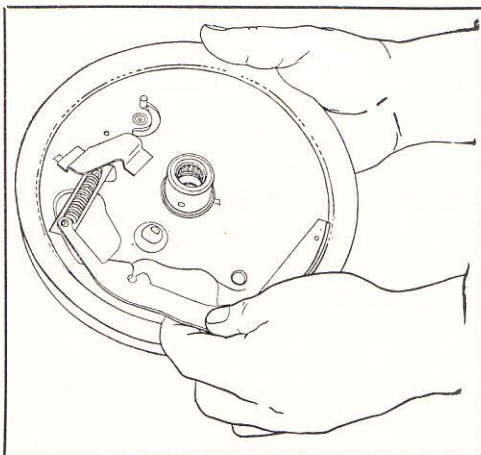




**Fig. 50**

1. Drive locking lever

(See Fig. 50). To dismantle the locking lever, remove the nut on the outside of the pulley, take out the bolt and prise the spring off the peg on the turn button. (See Fig. 51).

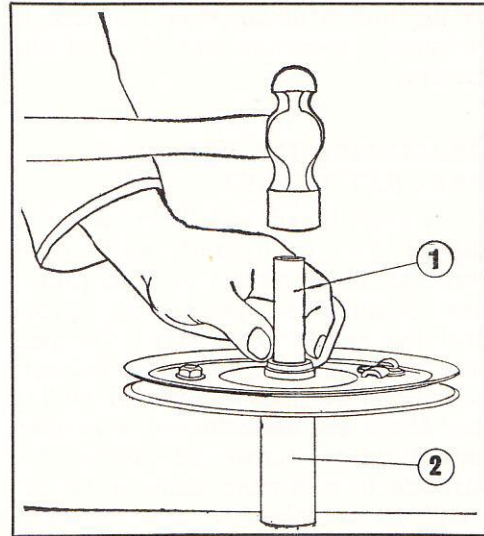


**Fig. 51**

Removing drive locking lever assembly

## REPLACING BOTTOM BRACKET PULLEY BEARINGS

The pulley rotates about the axle on two needle roller bearings, which are replaceable. Use a suitably shaped drift to drive out the old bearings. (See Fig. 52). On no account must bearings which have

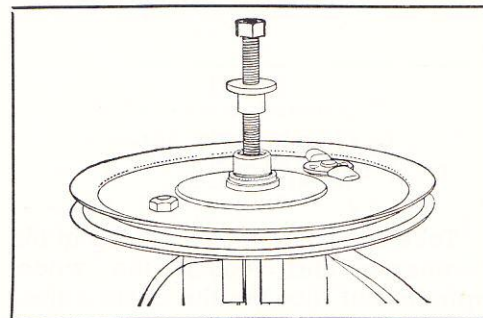


**Fig. 52**

Removing bottom bracket pulley bearings

1. Drift
2. Tubular support

been removed be re-used. When pressing in the new bearings, ensure that they are fitted the correct way round, i.e. the edge with the maker's identification numbers embossed should be showing at each side of the hub. The reason for this is because only the numbered edge of the bearing shell is thick enough to withstand the pressure required to fit the bearing in the hub. If the bottom bracket axle has three circlip grooves, then the bearing on the inner side of the pulley must be recessed



**Fig. 53**

Drawbolt arrangement for fitting pulley needle roller bearings

in the hub a distance of 1.5 mm. to provide clearance for the middle circlip.

## REASSEMBLING BOTTOM BRACKET PULLEY

To refit the drive locking lever, thread the spring and guide plate through the bracket on the pulley and locate the eye of the spring and the guide plate over the peg on the turnbutton. Insert the fulcrum bolt through the lever and pulley and fit the nut. Lock the nut in position by lightly centre-punching the threads in a similar manner to that employed originally.

## CHAIN ADJUSTMENT

The chain adjustment must be checked with the rear suspension in the normally laden position, that is, with the machine off its stand and with the rider's weight on the saddle.

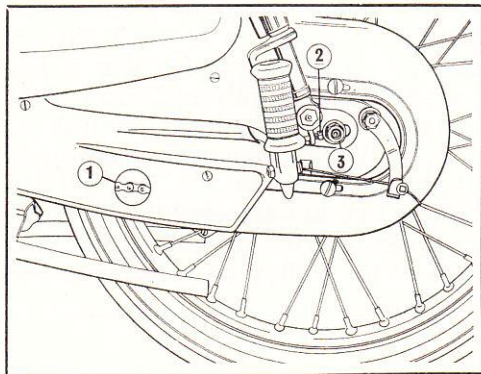


Fig. 54

Adjusting drive chain

1. Chain inspection aperture
2. Chain adjuster bolt
3. Wheel spindle nut

Take out the inspection plug in the chaincase and loosen the wheel spindle nut. Loosen the chain adjuster bolt locknuts and turn the bolts equally until the required adjustment is obtained. i.e.  $\frac{1}{2}$ " to  $\frac{3}{4}$ " up

and down at the inspection aperture. (See Fig. 54). Tighten the wheel spindle nut and check the wheel alignment. (See Fig. 55). If the alignment is satisfactory, tighten the adjuster locknuts and refit the plug in the inspection aperture. The rear portion of the chainguard may require repositioning after the chain has been adjusted.

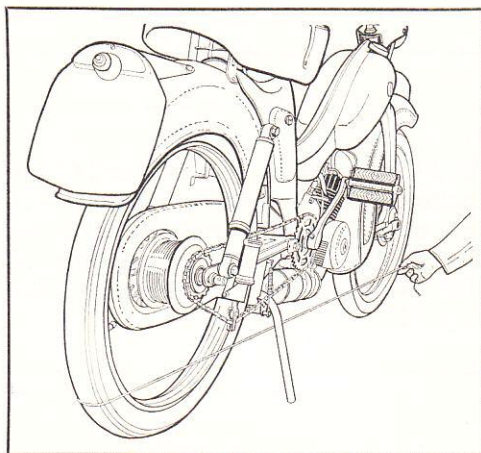


Fig. 55

Checking wheel alignment

## CHAIN LUBRICATION

It is not sufficient merely to put oil on a dirty chain. By far the best way to tackle this job is to remove the chains and wash them thoroughly in a bath of clean paraffin, using a stiff brush. Then wipe dry.

Check each chain for wear at this stage by placing it on a level surface alongside a rule and stretching it tight. 23 complete pitches (distance between centres of adjacent rollers) will come to the  $11\frac{1}{2}$ " mark on the rule when the chain is new. When the chain wears to a measurement of  $11\frac{3}{4}$ " for 23 pitches it should be replaced.

Immersion in a tin of warm S.A.E. 50 grade oil for 15 minutes or so will allow the lubricant to soak right into the bearing surfaces. Warm the



lubricant by standing the tin in very hot water. When the chain is thoroughly soaked, remove it and hang it up to drain off all surplus lubricant. Clean the sprockets before

refitting the chain. It is important when replacing a chain to make sure that the spring clip on the connecting link has its closed end pointing in the forward direction of chain travel.

## FRAME AND CYCLE PARTS SERVICING

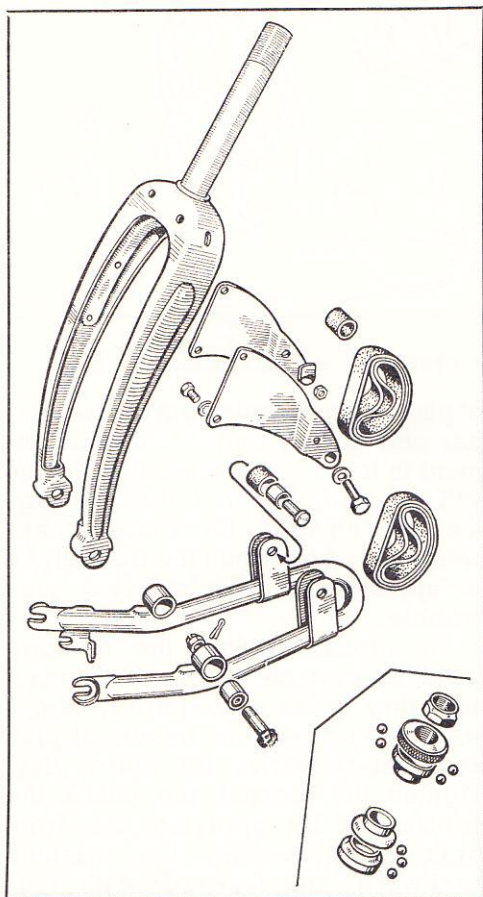


Fig. 56

Exploded view of front forks

### REMOVING FRONT FORKS

Support the front of the machine and remove the front wheel. Remove the handlebars and headlamp. Take out the two bolts at the bottom of the steering head fairing, unscrew the steering head locknut and remove the fairing. The suspension plates

bolted inside the front forks should now be detached and the lower mudguard stays and mudguard removed.

The forks can be removed from the machine after unscrewing the knurled steering head race. Take care not to lose any of the ball bearings from the steering head, if they are to be used again.

If necessary, the forks may be detached from the frame complete with the front wheel and mudguard.

### REFITTING FRONT FORKS

Refitting the front forks is simply a reversal of the removal procedure. Points to note are (1) Ensure that the steering head races are not pitted or damaged in any way. (2) There should be 25 steel ball bearings at each end of the fork stem. (3) The suspension rubber bands must be refitted carefully to ensure that they do not foul the front tyre.

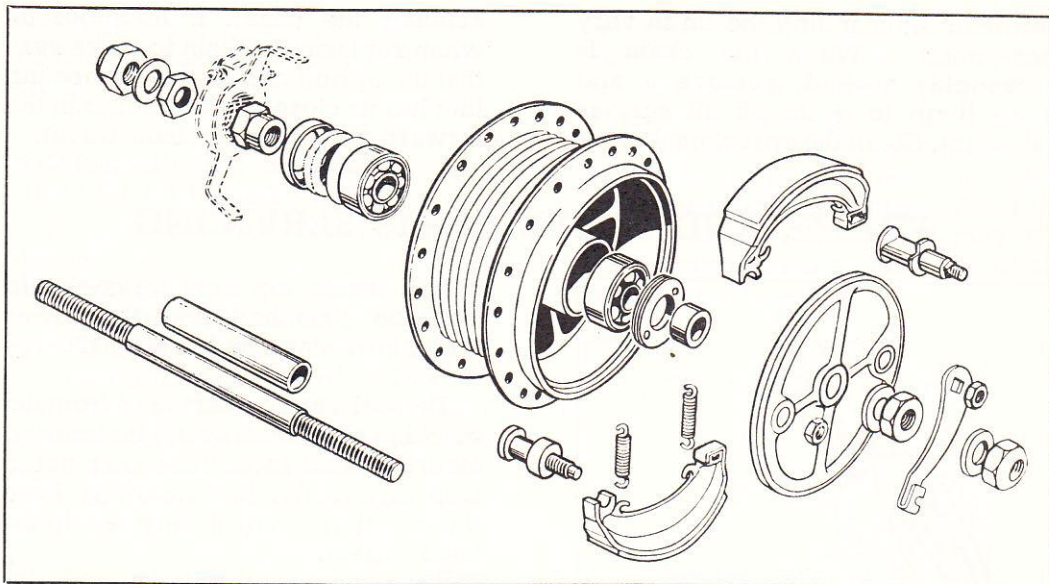
Do not forget to thoroughly grease the steering head bearings before replacing them.

### DISMANTLING FRONT FORKS

The front suspension is of leading pivoted fork type, controlled by rubber bands to give progressive resistance to fork movement. The fork is pivoted on bonded rubber bushes, which require no maintenance.

To dismantle the fork, remove the front wheel, take out the split pins





**Fig. 57**

Exploded view of front wheel hub

and remove the castellated nuts from the pivot bolts. Unhook the suspension rubber bands from the top anchorage, pull out the pivot bolts and remove the fork. If it is required to remove the rubber bands from the fork, file or grind off the rivet heads and push out the rivets. Each rivet passes through a steel bush around which is a rubber sleeve. The bonded rubber pivot bushes are a press fit in the fork.

### REASSEMBLING FRONT FORKS

Reassembling the front forks is quite straightforward and should present no difficulty. Before finally tightening the pivot bolt castellated nuts, it is recommended that the wheel should be refitted and the weight of the machine, together with its normal load, placed on the wheels, to ensure that the bonded rubber pivot bushes are not pre-loaded.

### STEERING HEAD ADJUSTMENT

The steering head is correctly adjusted when there is no trace

of play in the bearings but the handlebar still turns freely. If the adjustment is too tight the steering will be stiff in operation and the bearings may be damaged. If too loose, there will be a judder when the front brake is applied and the steering may wobble.

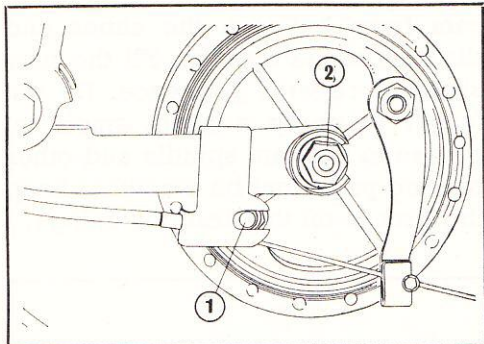
To adjust, slacken the steering head locknut and turn the knurled adjusting collar as required, clockwise to decrease the amount of play and anti-clockwise for more play. Tighten the locknut and check the adjustment by applying the front brake and rocking the machine backwards and forwards with your finger on the gap between the adjusting collar and the top frame cup where it will be possible to feel any play.

### REMOVING AND REFITTING FRONT WHEEL

Support the front of the machine by placing a box under the engine. Slacken off the front brake adjuster and remove the cable from the brake



arm. Disconnect the speedometer cable from the drive unit, loosen the wheel spindle nuts and disengage the washers from their recesses in the fork ends. Withdraw the wheel from the front forks.



**Fig. 58**

1. Brake plate peg
2. Wheel spindle nut

When refitting the front wheel, ensure that the peg on the brake plate is properly located in the slot in the right-hand fork end (See Fig. 58) and that the spindle is fully home in the fork ends before finally tightening the spindle nuts.

## DISMANTLING FRONT WHEEL HUB

Remove the wheel from the machine. The brake plate and speedometer drive unit are each retained by a nut on the spindle. Removal of the one on the brake side will allow the spindle and speedometer drive unit to be removed together. There is a plain washer on the outside of the brake plate and a tubular distance piece 6 mm. long between the brake plate and the bearing.

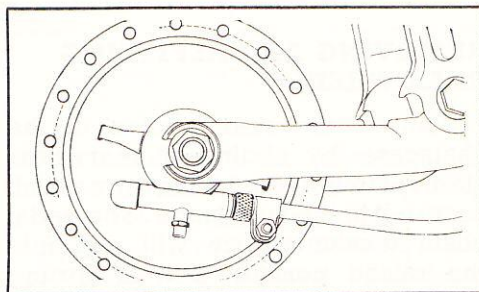
Non-adjustable ball journal bearings are fitted to the front wheel. If it is required to remove the bearings from the hub, use a long drift to dislodge the tubular distance piece between the bearings and to tap

out the bearing and felt seal opposite the brake side. Ensure that the bearing is tapped out as squarely as possible to prevent it "binding" in the hub shell. The bearing on the brake side is retained by a screwed plug, removal of which (left-hand thread) will allow the bearing to be tapped out. Care must be taken to prevent the threads for the retaining plug being damaged.

## REASSEMBLING FRONT WHEEL HUB

Lubricate and refit the bearing on the brake side first (See Fig. 64) and screw in the retaining plug. From the opposite side of the hub insert the tubular distance piece and the other bearing. (If the wheel spindle is temporarily inserted from the brake side it will maintain the correct alignment of the parts until the second bearing is in position). Ensure that the bearing is adequately greased, replace the thin shield washer, the felt seal and the cap. Insert the wheel spindle and speedometer drive unit (make sure that the tongues are properly located in the slots in the hub), place the 6 mm. distance piece on the spindle inside the brake drum and refit the brake plate, plain washer and nut.

Before finally tightening the brake plate nut, place the wheel in the



**Fig. 59**

Correct position of speedometer drive unit



forks with the brake plate peg correctly located and turn the speedometer drive unit until it is in the correct position to accept the drive cable. (See Fig. 59).

## REPLACING FRONT WHEEL BRAKE SHOES

The brake linings are bonded to the shoes. The most satisfactory way of relining the brakes is to exchange the old shoes for Factory Reconditioned ones, which are available from our Spare Parts Department.

To replace the shoes first remove the wheel and brake plate as described in previous sections. Remove the nuts from the brake shoe pivot bolt and the cam and take off the lever. Push the pivot bolt and cam away from the brake plate. Slide the cam from between the shoes and disconnect the springs. Fit the new shoes in reverse sequence. Do not forget to apply a slight smear of grease to the cam spindle and other moving parts, but be careful to keep the grease off the drum or linings.

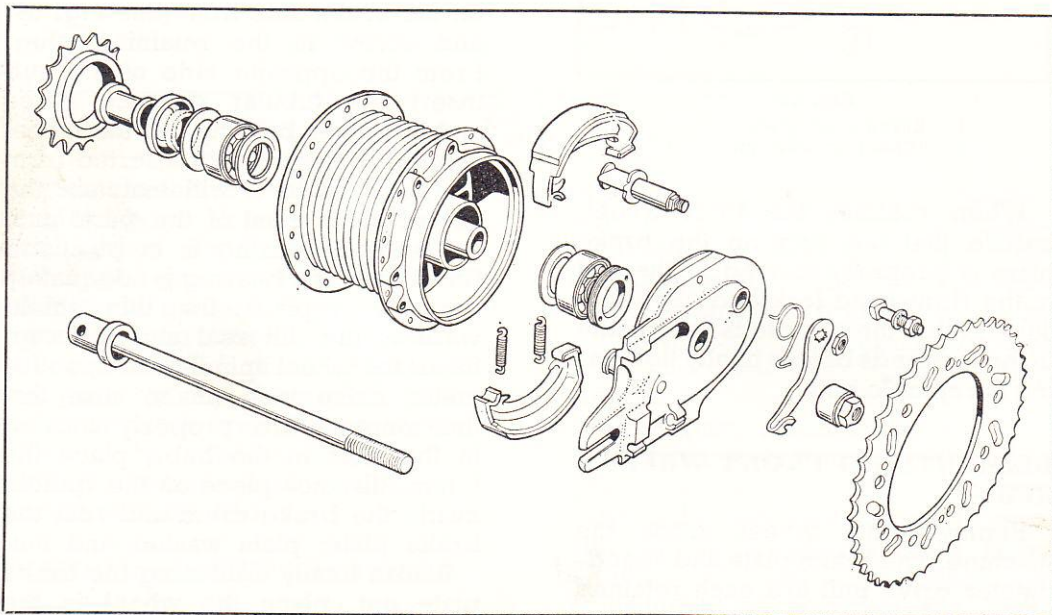


Fig. 60

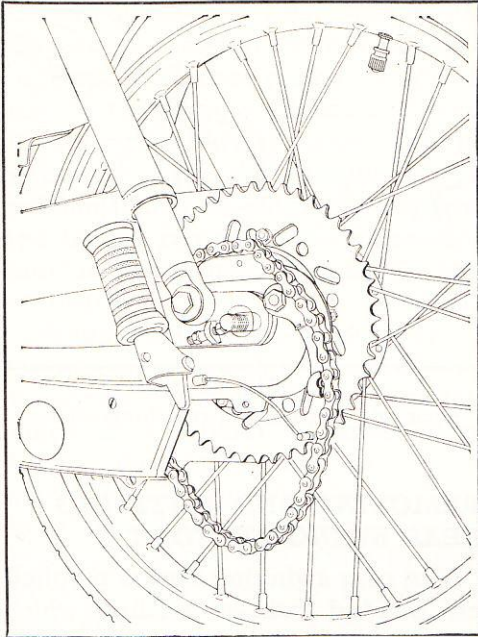
Exploded view of rear wheel hub

## REMOVING AND REFITTING REAR WHEEL

Remove the rear section of the chaincase by sliding it rearwards after removing the two screws which secure it to the hub flange. The pedal chain tensioner arm will clip into the raised position if it is sprung upwards towards the fork leg, to release the chain tension. Unscrew

the wheel spindle nut and pull out the spindle about half an inch. Push the wheel forward and loop both chains from their sprockets. (See Fig. 61). Disconnect the rear brake cable, withdraw the spindle completely and remove the wheel. It is not necessary to take out the spring links and split the chains when removing the rear wheel.

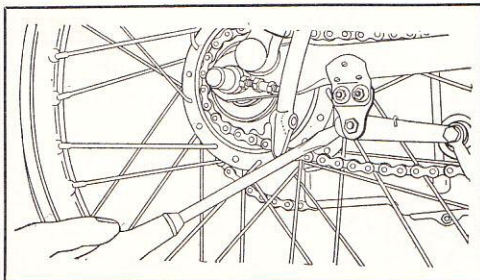




**Fig. 61**  
Rear wheel ready for removal

When refitting the wheel make sure that the brake plate anchoring slot and the brake outer cable are properly located and push the collars on the wheel spindle and nut firmly up against the chain adjuster bolts before finally tightening the spindle.

Do not forget to release the pedal chain tensioner arm by pushing the spring clip at the tensioner arm pivot with a screwdriver. (See Fig. 62).



**Fig. 62**  
Releasing pedal chain tensioner arm

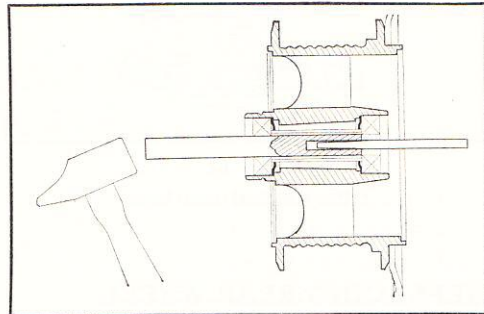
## SPECIAL TOOL AVAILABLE

6200655 Rear hub bearing extractor.

## REPLACING REAR WHEEL BEARINGS

When the wheel has been removed from the frame the brake plate is free to be removed.

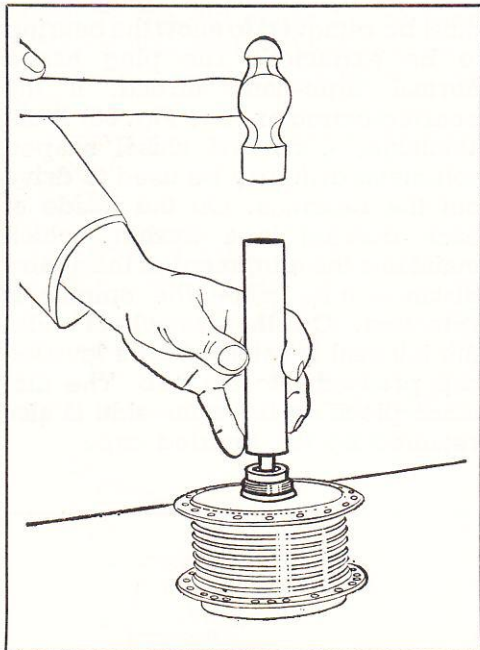
The bearing on the brake side is retained by a screwed plug which must be removed to allow the bearing to be extracted. The plug has a normal right-hand thread. If the bearing extractor (See Fig. 63) is not available, a narrow chisel shaped soft metal drift may be used to drive out the bearings. On the inside of each bearing is a washer, which maintains the alignment of the centre distance tube when the spindle is removed. On the freewheel side, the felt seal is retained by a knurled cap pressed into the hub. The distance piece on the same side is also retained by the knurled cap.



**Fig. 63**  
Using rear wheel bearing extractor

When replacing the bearings, fit the one on the brake side first, using a tube of suitable diameter (See Fig. 64) to drive in the bearing. (Do not forget the washer). Lubricate the bearing and screw in the retaining plug. Place the wheel spindle in

position temporarily, slide the centre distance tube over the spindle and into the hub, place the washer in position and fit the second bearing. Lubricate the bearing and refit the thin shield washer, the felt seal and cap/distance piece assembly. Replace the brake plate and refit the wheel.

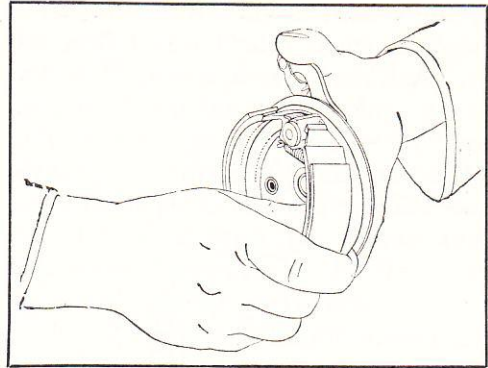


**Fig. 64**  
Fitting wheel bearings

## REPLACING REAR WHEEL BRAKE SHOES

Remove the brake shoes by prising one of them away from the back plate until it disengages from the cam and pivot. Pull off the shoes and springs.

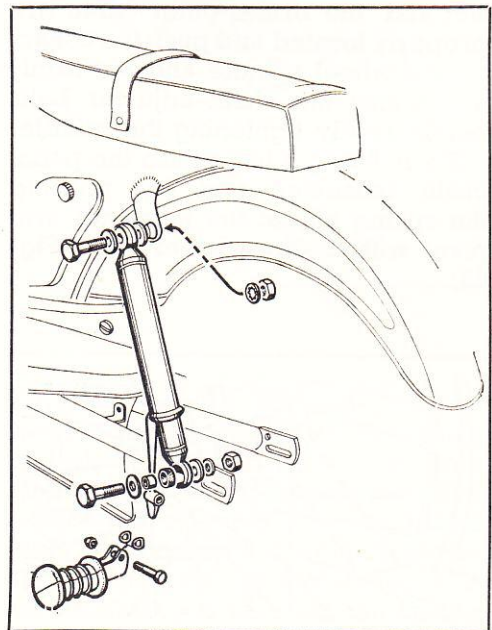
To refit the shoes, assemble the pair together with the springs, place one shoe in position on the cam and pivot and press down the other shoe until it clicks into place.



**Fig. 65**  
Removing and refitting rear brake shoes

## REMOVING AND REFITTING REAR SWINGING FORK

The rear swinging fork is pivoted on bonded rubber bushes which require no routine maintenance. To remove the fork, all the following parts must be detached to give access to the pivot bolt. (1) Fairings, (2)



**Fig. 66**  
Method of attaching rear suspension units



Clutch guard, (3) Rear wheel, (4) Chain case rear and outer, (5) Chains, (6) Bottom bracket pulley, (7) Pedal chain tensioner, (8) Chaincase inner. As the centre stand is mounted on the swinging fork, the weight of the machine must be otherwise supported before removing the suspension unit lower mounting bolts and the fork pivot bolt.

When the fork has been taken off the machine, detach the centre stand by removing its pivot bolt. Note that there is a tubular distance piece inside the pivot for the centre stand. No attempt should be made to remove the bonded rubber pivot-bushes from the fork. Only by destroying them can the bushes be removed.

When the swinging fork is being refitted the head of the pivot bolt should be to the left of the machine, towards the pulley. Do not forget to fit the small fairing bracket under the bolt head.

## REMOVING AND REFITTING REAR SUSPENSION UNITS

Each suspension unit is attached by two bolts. The lower bolt screws into the swinging fork, through a tapped hole, with a thin (5 mm.) locknut on the inside for additional security. Note that there is also a 5 mm. spacer on the lower bolt. The upper mounting employs a bolt, with a plain washer on each side of the suspension unit, a shakeproof washer on the inside of the frame bracket and finally the nut, 8 mm. thick. Use a new shakeproof washer when reassembling. To replace the rubber mounting bushes, simply remove the mounting bolt and press out the rubber bush, together with its internal steel sleeve. The method of attaching the pillion foot rest to the suspension unit is clearly shown in Fig. 66.

## HANDLEBAR, CONTROLS AND CABLES (EARLY MODEL)

### HANDLEBAR ADJUSTMENT

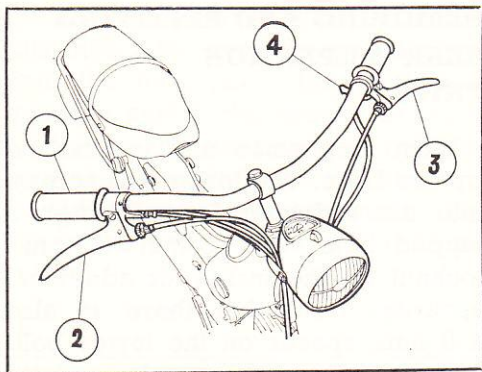
Early production models were fitted with the type of handlebar and controls shown in Fig. 67. The handlebar is secured to the steering stem through the medium of an expander cone, in the same manner as on a pedal cycle. To adjust the height, loosen off the expander bolt at the top of the handlebar stem by about three full turns and tap the head of the bolt with a mallet or block of hardwood to free the expander cone. The handlebar should then

be free for adjustment. To secure the handlebar it is only necessary to re-tighten the expander bolt. It is very important that at least  $2\frac{1}{2}$ " of handlebar stem should remain within the steering head to provide adequate security.

### REMOVING AND REFITTING HANDLEBAR

Pull off the left-hand grip. Remove the grubscrews which secure the brake levers and the twistgrip to the handlebar and disconnect the horn





**Fig. 67**

**Handlebar and controls (early pattern)**

1. Twistgrip, operating throttle and decompressor valves
2. Front brake lever
3. Rear brake lever
4. Enrichment (choke) control

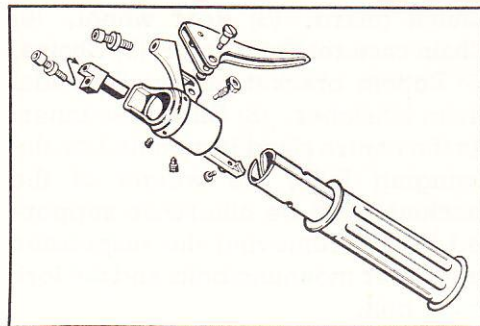
button. Free off the expander cone as described above and push the handlebar to its lowest position. Slide the twistgrip and brake levers off the handlebar. The handlebar is now free to be removed.

When refitting, ensure that the controls and cables are repositioned before locating and tightening the handlebar.

## TWISTGRIP

The twistgrip is illustrated in Fig. 68. It is secured to the handlebar by three grub screws. The largest of these screws has a reduced diameter which locates in a hole in the handlebar and ensures correct alignment. If for any reason the twistgrip is removed and refitted, this screw should be replaced first.

The twistgrip sleeve, which carries the rubber grip, is attached to the main body by means of the retaining screw and locknut in front of the body. To detach the sleeve, loosen the locknut, unscrew the retaining screw and twist the grip in the direction normally used for closing the throttle. To replace, reverse this procedure.



**Fig. 68**

Exploded view of twistgrip (early pattern)

The action of the throttle and decompressor cables is controlled by means of two sliding cursors which are drawn along their guides in the twistgrip body as the grip is rotated. A projection on the cursor engages with a spiral groove cut in the twistgrip sleeve and converts the rotary motion of the handgrip into a pull on the cables. Springs in the carburettor and on the decompressor valve provide the return action, and friction damping of the twistgrip is by means of the close fit of the sleeve on the handlebar. If more damping is required, the sleeve should be removed and carefully squeezed in a vice in order to reduce its diameter, the lengthwise slot in the sleeve facilitating the operation.

## ADJUSTING CONTROL CABLES

### Brake cables

The adjusters for the front and rear brake cables are screwed into the handlebar lever pivots and are easily adjusted without the need for tools.

The adjustment should be such that the brakes come into operation with the minimum amount of movement of the levers but there must be no binding of the brake shoes on



the drum. After adjustment each wheel should be checked to see that it is able to turn freely.

### **Decompressor cable**

The decompressor adjuster is screwed into the end of the sliding cursor in the twistgrip. (8 mm. spanner for locknut). The control must open the valve sufficiently far (2 mm.) but there must also be slight free play in the cable to ensure that the valve closes completely. The setting of the twistgrip must always be such that the throttle closes to "neutral" position before the decompressor valve starts to open.

### **Throttle cable**

Throttle cable setting is by means of the adjuster on the top of the carburettor mixing chamber. (8 mm. spanner). There must always be a slight amount of free play in the cable when the twistgrip is in the "neutral" position to prevent the throttle being operated when the handlebars are turned.

### **Enrichment (choke) cable**

The cable should be adjusted at the pinch bolt on the handlebar lever to give approximately  $\frac{1}{16}$ " free play.

## **REPLACING CONTROL CABLES**

### **Brake cables**

Disconnect the solderless nipple from the end of the cable remote from the handlebar and pull out the inner cable from the outer at the brake lever end. Detach the outer cable from the machine, if necessary. To fit a new cable, first place the outer cable in position on the frame, then thread the inner cable through the trunnion in the brake lever, through the brake lever fulcrum and on through the outer cable.

Fit the ferrule and the solderless nipple and adjust the cable.

### **Decompressor cable**

Detach the decompressor cable at the engine end by depressing the valve with the fingers and guiding the inner cable out of the loop in the valve spring. Loosen the inner cable clamp screw (which is screwed into the twistgrip body), pull out the inner cable and remove the cable from the machine. When refitting, insert the inner cable through the twistgrip sliding cursor and into the body, but do not tighten the clamp screw until the engine end of the cable has been connected and the adjustment checked.

### **Throttle cable**

To replace the throttle cable, remove the carburettor mixing chamber cover (See page 8), detach the throttle valve and spring and loosen the inner cable clamp screw which is screwed into the sliding cursor of the twistgrip. The complete cable may now be detached from the machine. To refit the throttle cable, place the complete cable in position on the machine and re-assemble the carburettor end first. At the twistgrip end, insert the inner cable into the sliding cursor, but do not fully tighten the clamp screw until the cable adjustment is satisfactory.

### **Enrichment (choke) cable**

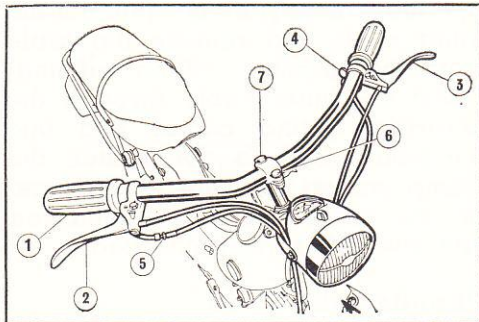
Remove the carburettor mixing chamber cover and detach the enrichment valve and cable through the slot in the cover. Loosen the clamp bolt on the control lever and pull out the inner cable, together with the valve and spring. Note which way the valve and spring are fitted, take them off the cable and refit them to the new inner cable in the same manner. Thread the inner cable through the outer, re-assemble the cable to the mixing



chamber cover and refit the cover to the carburettor. Reconnect the cable to the control lever. Ensure that

there is a little free play in the cable when in the "off" position and tighten the clamp bolt.

## HANDLEBAR, CONTROLS AND CABLES (LATER MODEL)



**Fig. 69**

Handlebar and controls (later pattern)

1. Twistgrip
2. Front brake lever
3. Rear brake lever
4. Choke control
5. Decompressor adjuster
6. Handlebar clamp bolt
7. Expander bolt

### HANDLEBAR ADJUSTMENT

In addition to the adjustment for height as already described for the early model handlebar, the later pattern may also be adjusted for "rake" by loosening the clamp bolt at the front of the handlebar stem.

### TWISTGRIP

The twistgrip is secured to the handlebar by two screws. Remove these screws to gain access to the cable operating drum and cable nipples. In the lower half of the twistgrip body is a spring and an adjusting screw to regulate the friction of the twistgrip. This should be set so that there is just sufficient friction to prevent the throttle from closing when the grip is released.

### ADJUSTING CONTROL CABLES

Screw type cable adjusters are

fitted to all cables except the one which operates the carburettor enrichment plunger. The throttle cable adjuster is situated on the top of the carburettor, the brake and decompressor cable adjusters are fitted in the cables adjacent to the handlebars. The enrichment control cable is adjusted by repositioning the solderless nipple on the cable at the control lever.

### REPLACING CONTROL CABLES

#### Brake cables

Brake cables may be changed by disconnecting each end and threading the complete cable through the frame attachments. The outer half of the chaincase should be removed to facilitate the routing of the rear cable.

#### Decompressor cable

Remove the two screws which secure the twistgrip to the handlebar, unhook the decompressor cable nipple from the operating drum, detach the other end of the cable from the engine and remove the cable from the frame attachments. When refitting, attach the cable at the engine end first, thread the other end into the lower half of the twistgrip body, together with the throttle cable, so that the two nipples lie on the joining face of the body. Push the lower half of the body into position on the twistgrip drum, when the nipples will spring into engagement with the drum. Be sure they are the right way round, i.e. decompressor cable to the rear.



## Throttle cable

The throttle cable may be removed and replaced in a similar manner to the decompressor cable, except, of course, the lower end, which is attached to the throttle valve.

## Enrichment (choke) cable

The enrichment cable may be changed in the same manner as that on the early pattern handlebars, as described on page 43.

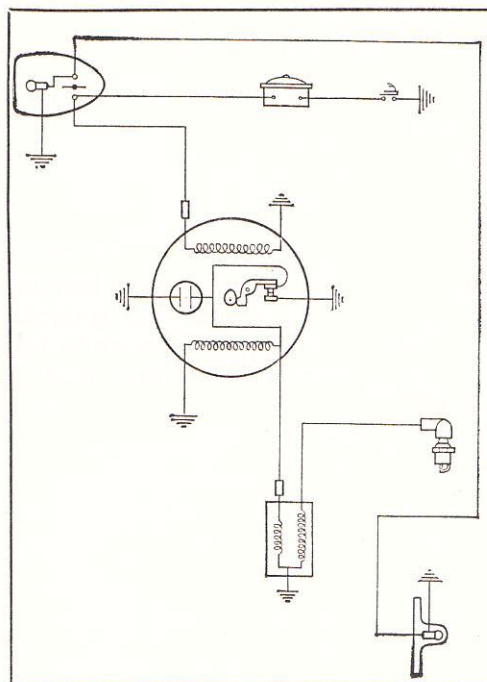
## LIGHTING SYSTEM AND SPEEDOMETER CABLE

Current is supplied from the magneto-generator to the lighting switch side terminal, from which point the horn supply wire is also taken. The remaining wire, on the other terminal, supplies current to the rear lamp, the headlamp bulb connection being through the spring blade. Turning the switch knob a quarter turn in either direction will complete the circuit, joining the two terminals of the switch together and operating both head and rear lamps. (See Fig. 70).

The terminals of the switch are of the spring clip type, which do not require the use of tools to disconnect the wires. To gain access to the headlamp bulb, remove the rim and reflector assembly. The bulb is a "bayonet" fitting in its holder.

To remove and dismantle the switch, take off the lamp rim and reflector assembly, slightly compress the switch knob spring on the underside of the switch and turn the spring until the end is freed from the slot in the switch shank. Slide the spring and switch rotor off the shank and remove the switch knob.

The terminal plate and insulator can now be removed and the wires disconnected. If necessary, the wires should be marked to enable them to be reconnected correctly. When reassembling, ensure that the rotor is fitted the right way up and that the spring is properly located in the slot.



**Fig. 70**

General wiring diagram

## HEADLAMP SETTING

The headlamp should be so adjusted that its beam strikes the road at a distance of approximately 18 ft. in front of the machine. The lamp can be tilted to the required position after loosening the two mounting bolts.

## REARLAMP

To change the rearlamp bulb, remove the plated screw which

---

## MOPED WORKSHOP MANUAL

---

retains the rearlamp lens. The bulb is screwed into the rearlamp body. When refitting, ensure that the rubber seal between the lens and the body is not damaged or misplaced.

### **SPEEDOMETER CABLE**

To remove the speedometer cable, take off the headlamp rim and re-

flector assembly and unscrew the upper end of the cable from the speedometer head. Disconnect the lower end of the cable from the drive unit by unscrewing the knurled collar. To enable the lower end of the cable to pass through the elongated hole in the fork leg the cable ferrule is detachable, after loosening the clip.



## **FAULT FINDING**

In the event of any difficulty being experienced, it should not be hard to remedy if it is tackled systematically with the aid of the following fault finding procedure.

### **IF THE ENGINE WILL NOT START OR STOPS OF ITS OWN ACCORD**

It may be because of:—

(A) Faulty carburation due to:—

- (1) Absence of fuel: refill the tank.
- (2) Fuel tap not turned on: open the tap.
- (3) Carburettor loose causing air leak: tighten.
- (4) Carburettor jet blocked: remove and clean the jet. At the same time clean the float chamber and filter and blow through the internal passages in the carburettor.
- (5) Fuel feed line blocked: clean out fuel pipe, tap and filters, preferably by blowing through with compressed air. Before replacing the pipe on the carburettor connection, turn on the tap to verify that fuel is flowing.
- (6) Fuel filler cap air vent blocked: clear vent.
- (7) Flooded carburettor: turn off the fuel tap, dry the carburettor by opening the throttle wide and kicking the engine over as rapidly as possible. If it does not fire after a few attempts, dry and clean the sparking plug. Before replacing, turn over the engine several times in order to eject the excess fuel from the cylinder. Then turn on the fuel tap again and carry out normal starting procedure. Should flooding still occur, check the float, float needle and seating.
- (8) Engine flooded with fuel due to excessive use of choke control: remedy as in point 7.
- (9) Choke plunger in carburettor not returning: check plunger and operating cable and adjust as necessary. Remedy as in point 7.
- (10) Water in fuel: drain fuel system, clean out carburettor. Refill with correct fuel.

(B) Faulty ignition due to:—

- (11) Dirty or oiled sparking plug: clean the plug.
- (12) Sparking plug electrode gap too wide: reset the gap. If the electrodes are badly burnt or corroded, replace the plug.
- (13) Faulty or broken sparking plug insulator: replace the plug.
- (14) Sparking plug lead disconnected: refit.
- (15) Insulation of H.T. lead to sparking plug faulty and spark shorting to earth: wrap the lead temporarily with insulating tape and replace it as soon as possible.
- (16) Dirty or loose connection in ignition circuit: check all connections and clean or tighten as necessary.
- (17) Dirty, burnt or maladjusted contact breaker points: clean or re-face points and set to correct clearance.

---

## M O P E D   W O R K S H O P   M A N U A L

---

- (18) Condenser or external H.T. ignition coil faulty: have them checked.
  - (19) **Note**—The sparking plug could get “wetted” with fuel due to carburettor flooding or to faulty ignition. It could be fouled by descending a long hill without opening the throttle occasionally or by letting the engine run light for too long. A sparking plug running too hot may cause the engine to stop due to “whiskering”, which is the formation of a conducting filament between the electrodes. A sparking plug running too cold fouls easily.
- (C) Mechanical trouble, as follows:—
- (20) Leakage at a crankcase joint, or at the crankshaft oil seals. Leakage at cylinder head gasket or at decompressor valve.

### **IF THE ENGINE STARTS, BUT STOPS IMMEDIATELY.**

- (21) In winter with a cold engine: let the engine warm up with the cold start control in operation.

### **IF THE ENGINE STOPS WHEN THE THROTTLE IS OPENED**

- (22) Engine still cold: allow it to warm up.
- (23) Carburettor jet blocked: clean it.
- (24) Fuel having difficulty in reaching carburettor: clean petrol pipe, tap and filters (see also points 1, 4, 5 and 6).

### **IF THE ENGINE DOES NOT RUN PROPERLY OR LACKS POWER**

- (25) Mixture too weak: see points 1, 3, 4, 5, 6 and 20. Jet too small: fit one size larger jet.
- (26) Mixture too rich (air cleaner blocked with dirt, float not maintaining correct fuel level, jet loose): wash the air cleaner in petrol or adjust or repair the carburettor as necessary. Jet too large: fit one size smaller jet.
- (27) Too much oil in petrol mixture: correct the mixture.
- (28) Sparking plug dirty or of unsuitable type, or with electrodes corroded or with incorrect gap: clean plug and set gap, or if necessary replace plug.
- (29) Contact breaker, condenser or ignition coil not functioning properly: have them checked.
- (30) Exhaust port or exhaust system choked with carbon: decarbonise and thoroughly clean.
- (31) Sparking plug loose in head: tighten securely.
- (32) Mechanical trouble: see points 3 and 20.
- (33) Piston rings gummed-in or excessively worn: clean grooves. Clean rings or replace if necessary.



## IF THE ENGINE FOUR-STROKES EXCESSIVELY

- (34) Mixture too rich: remedy as indicated in point 26.
- (35) Exhaust system choked: remedy as indicated in point 30.

**Note**—If the four-stroking is caused by too rich a mixture, this can easily be verified by turning off the fuel tap whilst riding the machine. Just before the engine stops due to lack of fuel, it will begin to fire correctly. If this does not prove to be the cause, then it is probably due to carbon deposits obstructing the exhaust system.

## MISFIRING

- (36) Fault with ignition equipment: check all items.
- (37) Fuel feed deficiency producing a weak mixture (usually accompanied by spitting back in the carburettor: see points 1, 3, 4, 5 and 6.

## IF THE ENGINE STOPS OF ITS OWN ACCORD

- (38) Fuel feed deficiency or absence of fuel if the stoppage is preceded by spitting back in the carburettor and back-firing in the exhaust.
- (39) Ignition defect if the stoppage is preceded by a bout of misfiring.

## IF THE ENGINE RACES BUT THE MACHINE DOES NOT INCREASE SPEED

- (40) Driving belt slipping: check condition of belt and clean or renew as required. (The belt can be contaminated by grease or oil due to excessive lubrication of the transmission.)

## FAILURE OF LIGHTS (Engine running)

- (A) This can be the result of blown bulb(s). Check by substitution of both headlamp and rearlamp bulb together. Otherwise if the headlamp bulb is defective the rearlamp bulb will blow due to overloading.
- (B) If, after checking as described in (A) the bulbs still do not light with the engine running, proceed to check the generating coil as follows:—
  - (1) Connect a test lamp, consisting of a spare headlamp and rearlamp bulb connected in parallel to give an 18 watt load across the main lead from the generator and a convenient point on the engine. With the engine running at a fast tick-over, the bulbs should light to near full brilliancy.
  - (2) If, after carrying out the test described in (1) the test bulbs light, proceed to check each stage of the circuit from the generator to the lighting switch, referring to the wiring diagram for open-circuits, breakages, etc. Should any of these faults exist, the bulb will not light. Also check for bad connections, etc., if the bulbs are dim. Check the continuity of the generating coil with a flashlamp battery and the appropriate bulb in series and connected across the main generator lead and a convenient point on the engine. The bulb should light if the coil is satisfactory.

# M O P E D   W O R K S H O P   M A N U A L

## LIGHT FLICKER (Engine running)

Examine the wiring for loose or dirty connections, or short circuits caused by faulty cable insulation. Check the bulb contacts. Rectify as necessary.

## HEADLAMP ILLUMINATION INSUFFICIENT

Check for discoloured bulbs or sagged filaments, replace the bulbs if necessary. Check the reflector; if tarnished or discoloured it should be replaced, as aluminised reflectors should not be cleaned or polished in any way whatsoever.

## SPECIAL WORKSHOP TOOLS

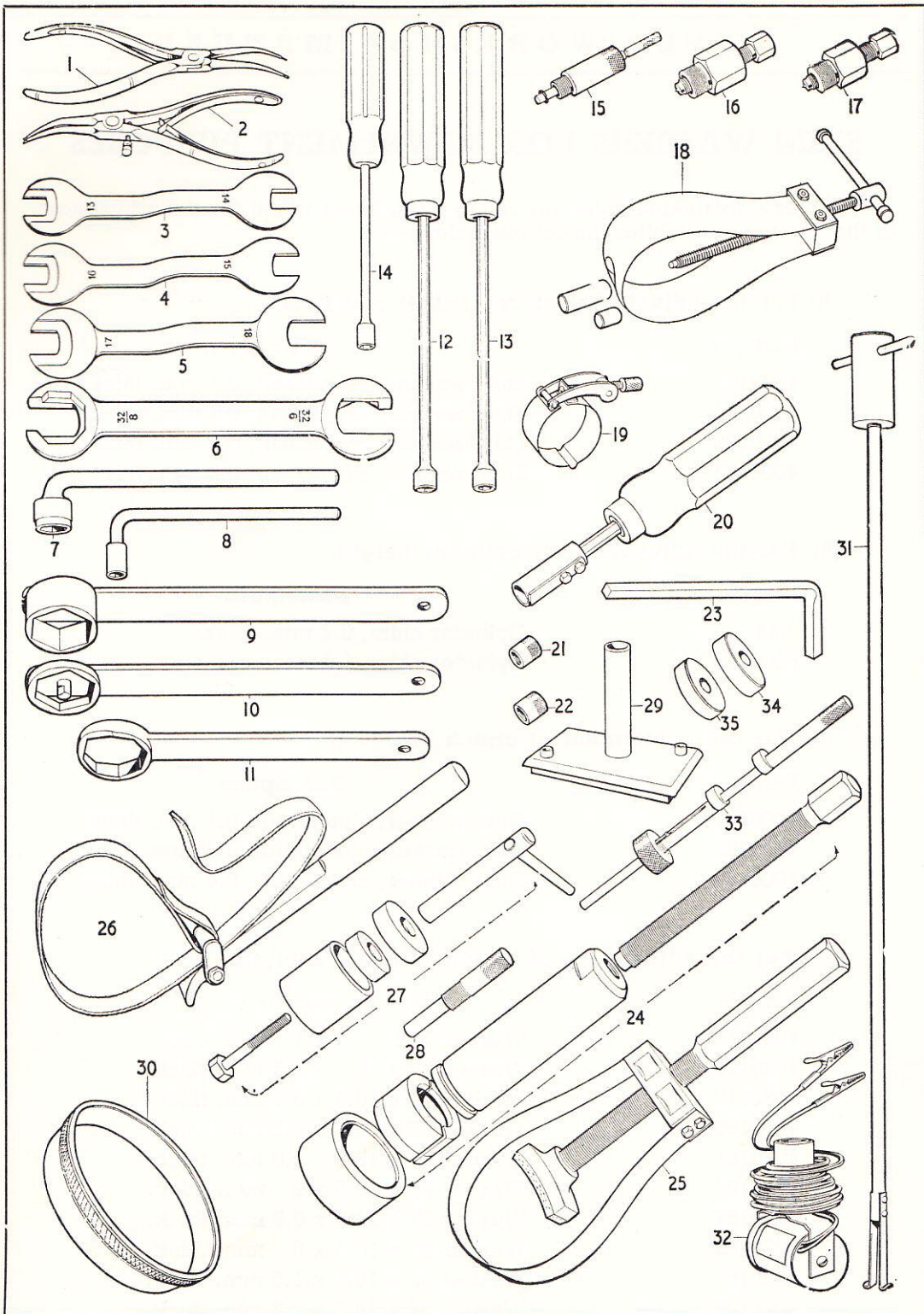
Available from our Spare Parts Department

ILLUST No.	PART No.	DESCRIPTION
1	6200542	Circlip pliers, internal type
2	6200543	Circlip pliers, external type
3	6200544	Cone spanner, 13 × 14 mm. AF
4	6200545	Cone spanner, 15 × 16 mm. AF
5	6200546	Cone spanner, 17 × 18 mm. AF
6	6200547	Steering head locknut spanner
7	6200548	Clutch drum nut wrench, 14 mm. AF
8	6200549	Cylinder head nut wrench, 10 mm. AF
9	6200550	Clutch hub nut wrench, 35 mm. AF
10*	6200551	Steering head lower bolt spanner, 32 mm. AF
11*	6200552	Steering head locknut spanner, 32 mm. AF
12	6200553	Jet socket spanner, 9 mm. AF
13	6200554	Jet socket spanner, 8 mm. AF
14	6200555	Grease nipple socket spanner, 6 mm. AF
15	6200556	Ignition advance gauge
16	6200557	Magneto cam extractor
17	6200558	Clutch drum extractor
18	6200559	Gudgeon pin extractor
19	6200560	Piston ring clamp
20	6200561	Clutch key positioning tool
21	6200562	Thread protector, 10 mm. × 1.0 mm. RH
22	6200563	Thread protector, 10 mm. × 1.0 mm. LH
23	6200565	Flywheel nut wrench, 10 mm. square
24	6200566	Crankshaft bearing extractor
25	6200567	Flywheel holding tool, steel band type
26	6200569	Flywheel holding tool, webbing strap type
27	6200570	Engine mounting rubber bush fitting tool
28	6200571	Piston stop
29	6200647	Clutch holding tool
30	6200346	Coil centralising ring
31*	6200649	Fork bush removal tool
32	6200651	Magnetic extractor for clutch washers
33	6200652	Crankshaft/crankcase gauge
34*	6200653	Dummy bearing, 42 × 15 × 13 mm.
35	6200654	Dummy bearing, 42 × 16 × 13 mm.
NI	6200655	Rear hub bearing extractor
NI*	6200650	Replacement springs and rivets for 6200649 fork tool

\*Items marked thus are not applicable to this machine

AF—Across flats.    NI—Not illustrated





**Fig. 71**  
Special workshop tools.

## **SHIM WASHERS FOR ADJUSTMENT PURPOSES**

These are obtainable from our Spare Parts Department for the adjustment of the various assemblies, as set out below:—

**(A) For the adjustment of crankshaft end float.**

Part No.	Description
4000161	Shim washer, crankshaft, 0.1 mm. thick.
4000284	Shim washer, crankshaft, 0.2 mm. thick.
4000162	Shim washer, crankshaft, 0.3 mm. thick.
4000163	Shim washer, crankshaft, 0.5 mm. thick.

**(B) For the adjustment of cylinder height.**

Part No.	Description
6200334	Cylinder shim, 0.2 mm. thick.
6200335	Cylinder shim, 0.4 mm. thick.

**(C) For the adjustment of clutch end float.**

Part No.	Description
4000401	Shim washer, clutch hub, 0.1 mm. thick.
4000402	Shim washer, clutch hub, 0.25 mm. thick.
4000403	Shim washer, clutch hub, 0.4 mm. thick.

**(D) For the adjustment of bottom bracket axle end float.**

Part No.	Description
4020115	Washer 27 x 16.5 x 1 mm. thick.
4020178	Washer 27 x 16.5 x 2.5 mm. thick.
4020179	Washer 27 x 16.5 x 3.2 mm. thick.
4020180	Washer 27 x 16.5 x 0.5 mm. thick.
4020181	Washer 27 x 16.5 x 0.8 mm. thick.
4020136	Washer 27 x 16.5 x 2 mm. thick.
4020187	Washer 37 x 16.5 x 0.8 mm. thick.
4020188	Washer 37 x 16.5 x 2 mm. thick.
4020189	Washer 37 x 16.5 x 1.5 mm. thick.
4020190	Washer 37 x 16.5 x 2.3 mm. thick.







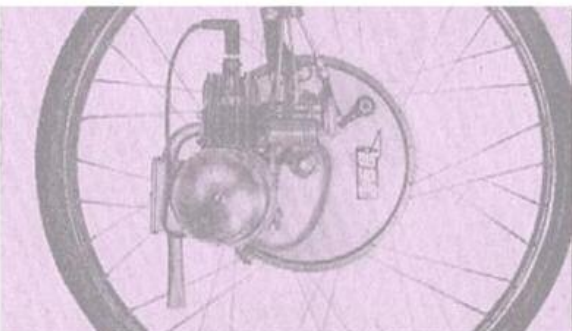




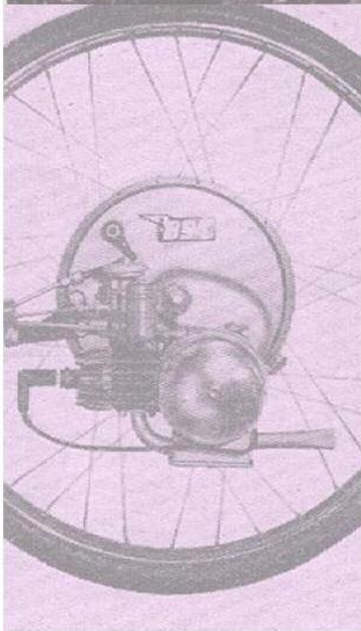




# IceniCAM Information Service



# IceniCAM Information Service



[www.icenicam.org.uk](http://www.icenicam.org.uk)