

# RALEIGH INDUSTRIES LIMITED

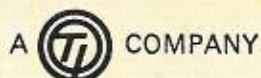

## SPARE PARTS AND PRICE LIST SUPPLEMENT

for Models RM.6 'Runabout' Standard and De-luxe :  
RM.8 'Automatic Mark II' : RM.9 'Ultramatic' ;  
and RM.5 'Supermatic'.

---

Additional colour finishes are now in use on Raleigh Mopeds. For the Sales Numbers relating to the new colours, refer to the lists on Pages 6 and 7 of this leaflet.

---

Commencing at Engine No. R128131 Raleigh 'Runabouts' are fitted with a modified cylinder barrel, Sales No. MTA 117. This cylinder may be used on engines with numbers later than R100100.

---

Larger carburettors are to be fitted to RM.6, RM.8 and RM.9 Models in the near future. The RM.6 and RM.8 carburettor is stamped AR2-10-667 and the RM.9 which differs internally is stamped AR2-10-664. The illustration and text on Pages 2 and 3 of this leaflet covers both types.

---

A new headlamp of Wipac manufacture is fitted to RM.8 Mopeds from Frame Number 8R.8574, and a Wipac tail lamp is fitted to all current Models from the following Frame Numbers:—

RM.5 — 5R.10725

RM.6 — 6R.46631

RM.8 — 8R.11013

RM.9 — 9R. 6117

These new components are illustrated and described on Pages 4 and 5 of this leaflet.

---

**Errata:** On Page 7 of the RM.9 Spare Parts List, the crankshaft assembly complete should be Sales Number MTA 311.

---

### RECOMMENDED PRICE LIST

Alterations and additions are given on pages 7 and 8 of this leaflet.

---

*Issued by:*—PARTS AND SERVICE DEPARTMENT  
JANUARY, 1966

6200999/21/14/S.21940

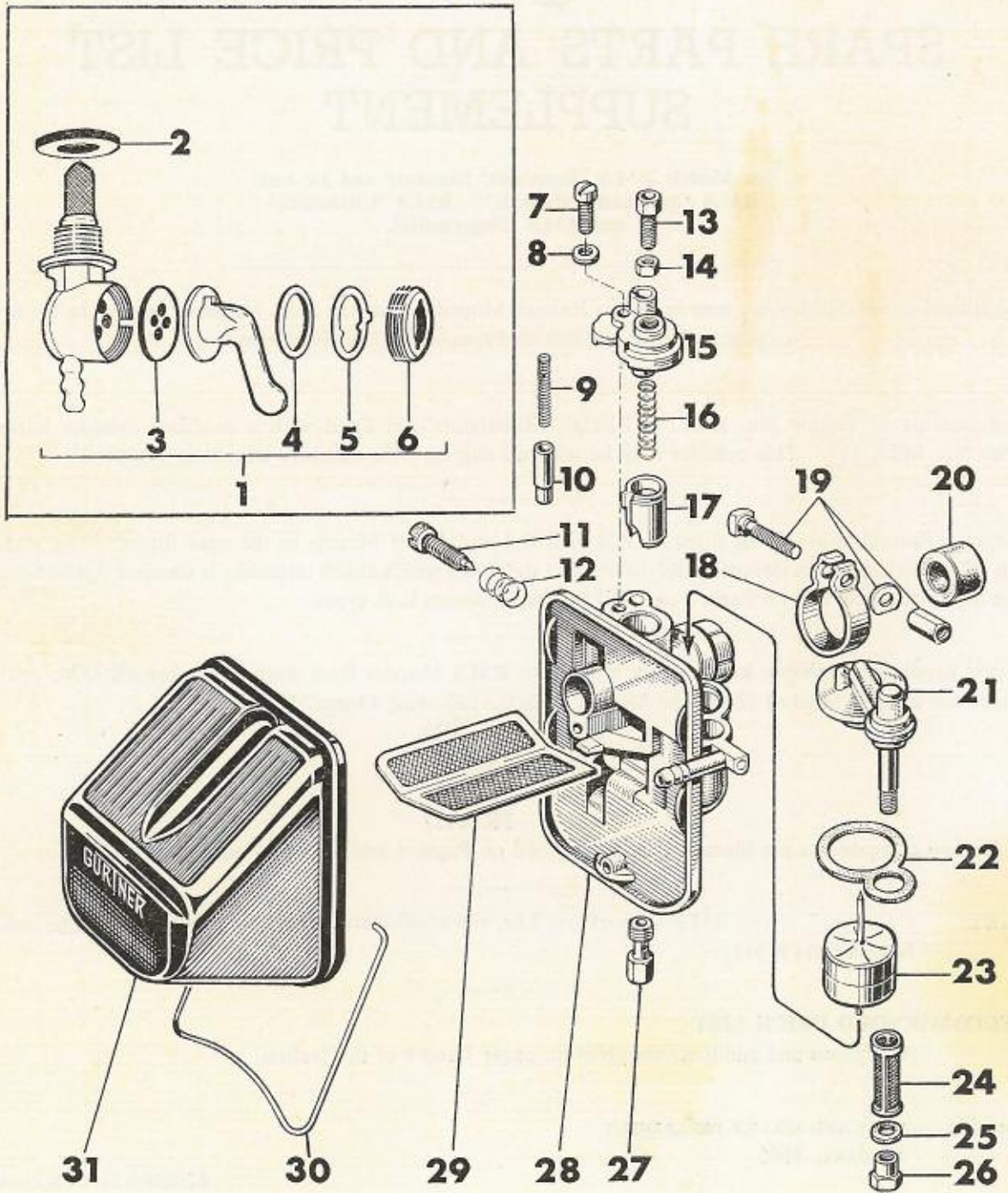



# CARBURETTOR AND FUEL TAP

# GROUP 'C'

RM6 and RM8—Type AR2-10-667  
 RM9—Type AR2-10-664

Illustration No.	Sales No.	Description	Number Off
1	MTH 217	Fuel tap .. .. .	1
2	MMW 245	Fibre washer, fuel tap, $\frac{1}{8}$ " .. .. .	V
or 2	MMW 246	Fibre washer, fuel tap, $\frac{3}{32}$ " .. .. .	V
3	MTH 195	Cork seal, fuel tap .. .. .	1
4	MTH 196	Fibre seal, tap lever .. .. .	1
5	MTH 197	Spring, fuel tap seal .. .. .	1
6	MTL 270	Screwed retainer, tap lever .. .. .	1
N.I.	MTH 216	Fuel pipe .. .. .	1
7	MTH 235	Screw, mixing chamber cover .. .. .	1
8	MMW 263	Washer, mixing chamber cover screw .. .. .	1
9	MTH 110	Return spring, enrichment plunger .. .. .	1
10	MTH 111	Enrichment plunger .. .. .	1
11	MTH 229	Adjusting screw, slow running .. .. .	1
12	MTH 123	Spring, adjusting screw .. .. .	1
13	MTH 106	Adjuster, throttle cable .. .. .	1
14	MMN 180	Locknut, cable adjuster .. .. .	1
15	MTH 231	Mixing chamber cover .. .. .	1
16	MTH 108	Return spring, throttle slide .. .. .	1
17	MTH 239	Throttle slide,—RM6 and RM8 .. .. .	1
or 17	MTH 226	Throttle slide,—RM9 .. .. .	1
18	MTH 117	Clip, carburettor stub .. .. .	1
19	MMP 142	Clip bolt, c/w nut and washer .. .. .	1
20	MTH 118	Insulating sleeve, carburettor stub .. .. .	1
21	MTH 232	Float chamber cover .. .. .	1
22	MTH 234	Joint, float chamber cover .. .. .	1
23	MTH 225	Float .. .. .	1
24	MTH 115	Fuel filter gauze .. .. .	1
25	MMW 248	Fibre washer, cap nut .. .. .	1
26	MTH 233	Cap nut, float chamber cover .. .. .	1
27	MTH 224	Main jet, No. 20.5 .. .. .	1
or 27	MTH 223	Main jet, No. 21 .. .. .	1
or 27	MTH 237	Main jet, No. 22 .. .. .	1
28	MTH 238	Carburettor, complete. (Parts No. 7 to 31) RM6 and RM8 .. .. .	1
or 28	MTH 222	Carburettor, complete. (Parts No. 7 to 31)—RM9 .. .. .	1
29	MTH 128	Air cleaner gauze .. .. .	1
30	MTH 228	Spring clip, air cleaner .. .. .	1
31	MTH 236	Air cleaner, complete. (Parts No. 29 to 31) .. .. .	1

V = Varies  
 N.I. = Not illustrated



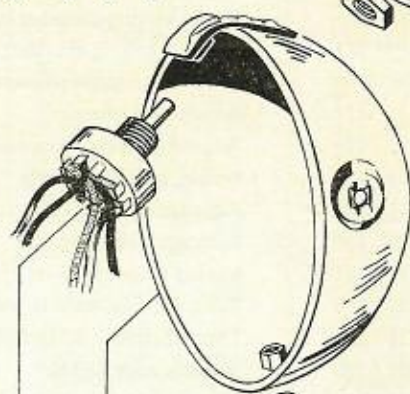
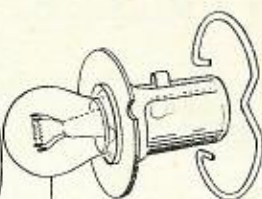
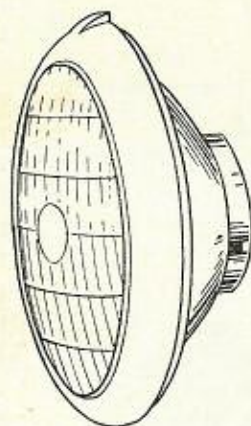
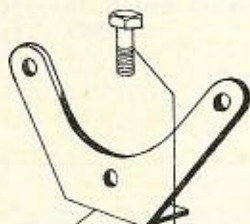
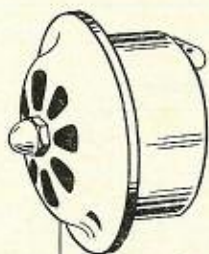
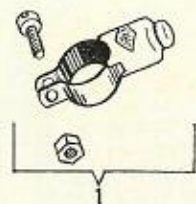

9

10

11

12

13

14

15

16

17

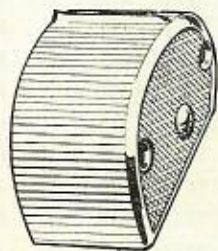
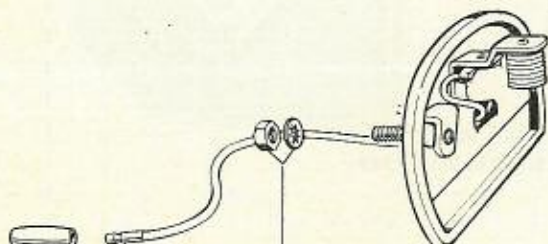

18

19

20

22

23

24

21

# LIGHTING AND ELECTRIC HORN

# GROUP 'K'

<i>Illustration No.</i>	<i>Sales No.</i>	<i>Description</i>	<i>Number Off</i>
1	MTP 197	Horn button, c/w screw and nut .. .. .	1
2	MTP 123	Electric horn kit, complete .. .. .	1
3	MMB 300	Screw, 3 B.A., horn to bracket .. .. .	3
4	MMW 359	Spring washer, horn to bracket screw .. .. .	3
5	MTP 124	Bracket, horn mounting .. .. .	1
6	MMW 101	Plain washer .. .. .	1
7	MMN 189	Self locking nut, horn bracket mounting bolt .. .. .	1
8	MMB 194	Bolt, horn bracket mounting .. .. .	1
9	MTP 209	Headlamp lens and reflector assembly .. .. .	1
10	MTP 219	Headlamp bulb, 6v. 15/15w. S.B.C. .. .. .	1
11	MTP 211	Spring ring, bulb holder retaining .. .. .	1
12	MTP 212	Lighting switch .. .. .	1
13	MTP 214	Headlamp shell, c/w retaining nuts .. .. .	1
14	MTP 215	Clip and screw, headlamp lens retaining .. .. .	1
15	MTP 213	Knob, lighting switch .. .. .	1
16	MMW 101	Plain washer, headlamp securing bolt .. .. .	2
17	MMB 194	Bolt, headlamp securing .. .. .	2
S.A.	MTP 216	Headlamp, c/w wiring harness .. .. .	1
N.I.	MTP 217	Wiring harness, c/w bulb holder and switch.. .. .	1
N.I.	MTP 218	Grommet, headlamp shell .. .. .	1
18	MTP 120	Connector .. .. .	1
19	MTP 155	Connector nipple .. .. .	2
20	MMN 234	Nut and washer, tail lamp fixing .. .. .	2
21	MTP 223	Tail lamp, complete .. .. .	1
22	MTP 158	Bulb, tail lamp. 6v. 3w. M.E.S. .. .. .	1
23	MTP 225	Lens, tail lamp .. .. .	1
24	MMB 335	Screw, tail lamp lens .. .. .	2

S.A. = Sub Assembly  
N.I. = Not illustrated



## SALES NUMBERS FOR ADDITIONAL COLOURS

### RM.5 'Supermatic' (Telescopic front fork model)

Group	Illustration No.	Sales No. Neptune Blue	Description
G	1	MTF 200	Frame
G	24	MTF 201	Rear swinging fork, c/w inner chaincase
G	33	MTL 421	Guard, bottom bracket sprocket
G	34	MTF 202	Inner half, chaincase
G	35	MTL 422	Outer half, chaincase
G	36	MTL 423	Chain cover, rear
G	N.I.	MTL 424	Front mudguard
G	N.I.	MTL 425	Stay, front mudguard, upper
G	N.I.	MTL 426	Stay, front mudguard, centre
G	N.I.	MTL 427	Stay, front mudguard, lower
H	8	MTL 361	Dual seat

### RM.6 'Runabout'

Group	Illustration No.	Sales Nos.		Description
		Neptune Blue	De-luxe Finish Royal Carmine	
F	1	MTJ 211	MTJ 210	Front fork, bare
G	5	MTF 196	MTF 194	Frame assembly
G	14	MTL 407	MTL 393	Fuel tank
G	16	MTL 408	MTL 102	Filler cap
G	17	MTL 400	MTL 388	Tailpiece
G	22	MTL 401	MTL 394	Splash plate
G	25	MTL 405	MTL 395	Tank support stay
G	27/44	MTL 404	MTL 283	Stay, rear mudguard
G	28	MTL 399	MTL 390	Rear mudguard
G	31	MTL 406	MTL 389	Front mudguard
G	33	MTF 197	MTF 169	Vee-belt guard
G	41	MTL 402	MTL 391	Fairing, L.H.
G	N.I.	MTL 403	MTL 392	Fairing, R.H.
G	N.I.	MTL 396	MTL 396	Frame transfer, 'Raleigh'
G	N.I.	MTL 397	MTL 397	Fairing transfer, 'Runabout'
G	N.I.	—	MTL 398	Frame transfer, 'De-luxe'
M	N.I.	MTR 150 (P/Grey)	MTR 330	Legshield kit

### RM.8 'Automatic Mk II'

Group	Illustration No.	Sales No. Royal Blue	Description
G	5	MTL 411	Stay, front mudguard, upper and lower
G	6	MTL 410	Stay, front mudguard, centre
G	8	MTL 409	Front mudguard
G	31	MTL 415	Fuel tank



## SALES NUMBERS FOR ADDITIONAL COLOURS

### R.M.9 'Ultramatic'

Group	Illustration No.	Sales No. Golden Sand	Description
Fb	1	MTJ 215	Fork tube assembly, c/w covers
Fb	2	MTJ 216	Fork tube cover, R.H.
Fb	3	MTJ 217	Fork tube cover, L.H.
Fb	21	MTJ 219	Steering stem
Fb	S.A.	MTJ 218	Front fork assembly, complete
G	7	MTL 437	Fuel tank
G	10	MTL 432	Tailpiece
G	18	MTF 203	Frame
G	22	MTL 433	Splash plate
G	25	MTL 429	Tank support stay, R.H.
G	N.I.	MTL 436	Chainguard
G	N.I.	MTL 430	Tank support stay, L.H.
G	27	MTL 428	Stay, rear mudguard
G	28	MTL 431	Rear mudguard
G	29	MTL 438	Front mudguard
G	30	MTL 440	Stay, front mudguard, upper and lower
G	31	MTL 439	Stay, front mudguard, centre
G	42	MTL 434	Fairing, L.H.
G	N.I.	MTL 435	Fairing, R.H.
K	S.A.	MTP 245	Headlamp, c/w wiring harness
K	13	MTP 246	Headlamp shell, c/w retaining nuts

### NEW ACCESSORY

A new luggage carrier is now introduced to fit Mopeds with rear mounted fuel tanks. The carrier is supplied complete with fittings and is available from Parts and Service Dept. Please quote the following Sales Number and Description when ordering.

MTR 336 Luggage carrier, c/w fittings

### MOTOR SPARES RECOMMENDED PRICE LIST

## Alterations and Additions

#### ALTERATIONS

MTB 110	The price should read	10s. 3d. each
MTD 194	" " " "	12s. 0d. each
MTD 197	" " " "	10s. 0d. each
MTD 223	" " " "	10s. 9d. each
MTD 236	" " " "	£1 16s. 8d. each
MTD 237	" " " "	1s. 9d. each
MTD 250	" " " "	12s. 8d. each
MTD 258	" " " "	11s. 11d. each
MTM 149	" " " "	1s. 6d. each
MTM 153	" " " "	2s. 6d. each
MTP 120	" " " "	3s. 4d. per ten
MTP 209	" " " "	15s. 0d. each
MTR 141	" " " "	£3 18s. 6d. each



### ADDITIONS

Sales No.	£	s.	d.	Sales No.	£	s.	d.	Sales No.	£	s.	d.	Sales No.	£	s.	d.
BYS 672	1	0	0	MTH 240	2	12	6	MTL 407	3	7	2	MTL 441	2	6	doz.
MMB 351	3	6	doz.	MTJ 210	1	16	0	MTL 408	5	8		MTM 168	4	0	doz.
MMN 301	9			MTJ 211	1	16	0	MTL 409	16	2		MTN 253	10		
MMN 302	2	6	doz.	MTJ 212	3	8	10	MTL 410	9	0		MTP 244	3	11	0
MMN 303	3	6	doz.	MTJ 213	1	1	0	MTL 411	5	0		MTP 245	3	2	5
MMN 304	9			MTJ 214	7	18	6	MTL 412	11	3		MTP 246	19	5	
MMN 306	3	6	doz.	MTJ 215	4	13	10	MTL 413	2	1		MTP 247	3	2	5
MMW411	1	3	doz.	MTJ 216	13	5		MTL 414	4	2		MTP 248	19	5	
MMW412	1	6	doz.	MTJ 217	13	5		MTL 415	3	7	2	MTP 249	1	3	doz.
MMW413	1	6	doz.	MTJ 218	9	3	0	MTL 416	7	11		MTR 328	3	6	
MTA 312	40	5	0	MTJ 219	1	1	0	MTL 417	4	0		MTR 329	3	12	6
MTA 313	45	15	0	MTL 386	19	8		MTL 418	15	4		MTR 330	3	18	6
MTA 314	51	0	0	MTL 387	16	2		MTL 419	15	4		MTR 331	1	17	6
MTA 315	3	10		MTL 388	4	2		MTL 420	9			MTR 332	3	3	
MTD 258	11	11		MTL 389	19	8		MTL 421	7	9		MTR 333	3	18	6
MTF 194	16	10	6	MTL 390	11	3		MTL 422	12	1		MTR 334	3	18	6
MTF 195	17	4	pair	MTL 391	15	4		MTL 423	16	4		MTR 335	4	19	0
MTF 196	16	10	6	MTL 392	15	4		MTL 424	2	7	0	MTR 336	15	6	
MTF 197	4	7		MTL 393	3	7	2	MTL 425	5	3		MTR 337	4	4	0
MTF 198	16	10	6	MTL 394	4	0		MTL 426	9	0		MTR 338	4	4	0
MTF 199	4	7		MTL 395	7	11		MTL 427	5	0		MTR 339	4	4	0
MTF 200	18	5	0	MTL 396	4	0	doz.	MTL 428	2	0		MTR 340	4	4	0
MTF 201	5	2	0	MTL 397	6	0	doz.	MTL 429	7	11		MTR 341	11	6	
MTF 202	13	9		MTL 398	4	0	doz.	MTL 430	7	11		MTR 342	1	1	
MTF 203	16	10	6	MTL 399	11	3		MTL 431	11	3		MTR 343	9		
MTH 238	6	12	6	MTL 400	4	2		MTL 432	4	2		MTR 344	9		
MTH 239	6	3		MTL 401	4	0		MTL 433	4	0		MTR 345	9	pair	
				MTL 402	15	4		MTL 434	15	4		MTR 346	1	9	
				MTL 403	15	4		MTL 435	15	4					
				MTL 404	2	1		MTL 436	13	5					
				MTL 405	7	11		MTL 437	3	7	2				
				MTL 406	19	8		MTL 438	16	2					
								MTL 439	9	0					
								MTL 440	5	0					



# IceniCAM Information Service

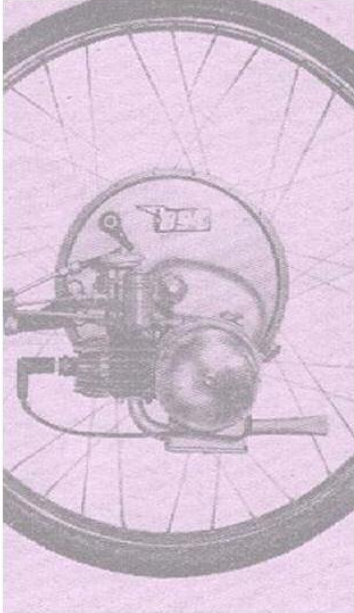

[www.icenicam.org.uk](http://www.icenicam.org.uk)