

RALEIGH

Automatic

MOPED

MODEL RM4

AND

RALEIGH RUNABOUT

MODEL RM6

WORKSHOP MANUAL

PRICE 9/6

RALEIGH

Automatic

MOPED

MODEL RM4

AND

RALEIGH RUNABOUT

MODEL RM6

WORKSHOP MANUAL

RALEIGH INDUSTRIES LIMITED

LENTON BOULEVARD

NOTTINGHAM

Telephone : NOTTINGHAM 77761 Telegrams : RALIND NOTTINGHAM

Telex : NOTTINGHAM 37681

An illustrated Spare Parts List covering this model is
available at a price of 3/- post free.

INDEX

	Page
Technical Data	5
Recommended Lubricants	6
Notes on Workshop Practice	7
Fault Finding	47
Shim Washers for Adjustment Purposes	52
Special Workshop Tools	50
FRAME AND CYCLE PARTS—SERVICING	33
FRONT FORKS (RM4)	38
Front Forks—Removing	38
Front Forks—Dismantling	40
Front Forks—Reassembling	40
Front Forks—Refitting	39
Steering Head Bearings—Adjusting	41
Steering Stem—Removing	39
FRONT FORKS (RM6)	41
Front Forks—Removing and Refitting	41
FRONT WHEEL	33
Front Brake (RM6)	36
Front Wheel—Removing	33
Front Wheel Bearings—Adjusting	34
Front Wheel Bearings—Replacing (RM4)	35
Front Wheel Brake Shoes—Replacing (RM4)	35
Front Wheel—Refitting	33
HANDLEBAR, CONTROLS & CABLES (EARLY MODEL RM4)	41
Control Cables—Adjusting	42
Control Cables—Replacing	43
Handlebar—Adjusting	41
Handlebar—Removing	41
Twistgrip	42
HANDLEBAR, CONTROLS AND CABLES	44
Control Cables—Adjusting	44
Control Cables—Replacing	44
Handlebar—Adjusting	44
Handlebar—Removing	44
Twistgrip	44

INDEX (continued)

	Page
LIGHTING	45
Headlamp (RM4)	45
Headlamp (RM6)	46
Headlamp—Setting	46
Rearlamp	46
 REAR WHEEL	 36
Rear Wheel—Removing	36
Rear Wheel Bearings—Replacing (RM4)	37
Rear Wheel Bearings (RM6)	37
Rear Wheel Brake Shoes—Replacing (RM4)	38
Rear Wheel Brake Shoes—Replacing (RM6)	38
Rear Wheel—Refitting	36
 POWER UNIT SERVICING	 8
AUTOMATIC CLUTCH	12
Clutch Drum—Removing	14
Clutch Body—Removing	14
Clutch Body—Dismantling	15
Clutch Body—Reassembling	16
Clutch Body—Relining	15
Clutch—Refitting	15
ENGINE REMOVAL AND ROUTINE MAINTENANCE	8
Decarbonising	10
Exhaust System—Decarbonising	11
Engine—Decarbonising	11
Decompressor Valve	12
Drive Belt—Fitting	10
Engine Unit—Removing	8
Engine Unit—Refitting	10
ENGINE DISMANTLING AND REASSEMBLING	21
Cylinder and Piston—Dismantling	22
Crankcase—Dismantling	23
Main Bearings—Removing	23
Crankcase—Reassembling	24
Piston Sizes	26
Piston—Refitting	25
Piston Rings	25
Cylinder—Refitting	25

INDEX (continued)

	Page
FLYWHEEL MAGNETO	16
Flywheel—Removing	17
Contact Breaker Points	17
Contact Breaker—Replacing	18
Magneto—Timing	19
Condenser—Replacing	19
Coils—Replacing	19
Stator Plate—Removing	20
Flywheel—Replacing	17
 FUEL SYSTEM	 26
Carburettor—Adjusting	28
Carburettor—Removing	26
Carburettor—Dismantling	27
Carburettor—Reassembling	28
Carburettor—Refitting	27
Fuel Tap	29
 TRANSMISSION—SERVICING	 29
Chain—Adjusting	32
Chain—Lubricating	33
Bottom Bracket Axle—Removing	29
Bottom Bracket Axle Bearings—Replacing	30
Bottom Bracket Pulley—Removing	29
Bottom Bracket Pulley—Dismantling	30
Bottom Bracket Pulley Bearings—Replacing	31
Bottom Bracket Pulley—Reassembling	32
Bottom Bracket Axle—Refitting	32

TECHNICAL DATA

ENGINE

Single cylinder, two-stroke with twin transfer ports. Aluminium alloy cylinder with hard chrome plated bore. Aluminium alloy cylinder head and piston. Two cast iron piston rings.

Bore: 39 mm.

Stroke: 41.75 mm.

Cubic capacity: 49.9 cc.

Piston clearance (bottom of skirt):
·0004" min., ·0008" max.

Piston ring gap: ·004" min., ·008" max.

Crankshaft end float: ·004" min., ·008" max.

IGNITION

NOVI flywheel magneto with external H.T. ignition coil.

Contact breaker points gap:
·016"—·018".

Ignition advance: $\frac{1}{4}$ " (·109") ±
·004" before T.D.C.

Sparking plug: Lodge HN;
Champion L86; KLG F75.

Sparking plug electrode gap:
·016"—·018".

CLUTCH

Automatic, centrifugally operated.

PRIMARY DRIVE

Vee-belt.

Ratio: 3.76 : 1.

FINAL DRIVE

Roller chain.

Ratio: 3.67 : 1 (12t to 44t).

Chain size: $\frac{1}{2}$ " × $\frac{3}{16}$ " × ·305" roller
×96 pitches.

OVERALL GEAR RATIO: 13.8 : 1.

PEDAL DRIVE

Roller chain.

Ratio: 1.78 : 1 (32t to 18t).

Chain size: $\frac{1}{2}$ " × $\frac{1}{8}$ " × ·305" roller ×
93 pitches.

ELECTRICAL SYSTEM

NOVI 18 w. Alternator.

Headlamp bulb: 6 v., 15 w.

Rearlamp bulb: 6 v., 3 w.

FUEL SYSTEM

Tank capacity: RM4, 1 $\frac{1}{4}$ galls.
RM6, 1 $\frac{3}{8}$ galls.

Carburettor: GURTNER.

Main jet size: No. 20.

TYRES

Size: 23" × 2".

Pressures (lbs. per sq. in.): Front,
24; Rear, 38.

FRAME NUMBER POSITION

L.H. frame lug above rear wheel
spindle nut.

ENGINE NUMBER POSITION

Lower front of cylinder barrel.

RECOMMENDED LUBRICANTS

		BP	Castrol	Esso	Mobil	National Benzole	Shell
Engine (Petrol/oil ratio shown in brackets)	Two-Stroke Oils	Energol Two-Stroke Oil (20 : 1)	Two-Stroke Self-mixing Oil (16 : 1)	Esso Two-Stroke (2T) Motor Oil (16 : 1)	Mobilmix TT (16 : 1)	—	Shell 2T Two-Stroke Oil (20 : 1)
	Pre-Mixed fuels	BP-Zoom (20 : 1)	—	—	—	Hi-Flu* (20 : 1)	Shell 2T Mixture (20 : 1)
Running in: Where a (20 : 1) ratio is specified, use (16 : 1) for running in. Where a (16 : 1) ratio is specified, use (12 : 1) for running in.							
Chains	Grade	Energol SAE 50	Grand Prix	Esso Extra Motor Oil 40/50	Mobiloil BB	—	Shell X-100 50
Working Joints, Control Cables, etc.	Grade	Energol SAE 20W	Castrolite	Esso Extra Motor Oil 20W/30	Mobiloil Arctic	—	Shell X-100 20W
All Greasing Applications	Grade	Energol L2	Castrol LM	Esso Multi-purpose Grease H	Mobil-grease MP	—	Retinax A

*NATIONAL BENZOLE CO. LTD., ALSO MARKET SHELL AND BP LUBRICANTS

NOTES ON WORKSHOP PRACTICE

PRELIMINARY CLEANING

Before commencing any dismantling or repair work it is always advisable to clean the machine thoroughly, or at least the parts on which the repair work is to be carried out and those adjacent. It often happens that during this preliminary cleaning, one can spot faults which otherwise might pass undetected, such as loose or missing nuts and bolts, damaged or worn components, etc.

Too much emphasis cannot be laid on the need for tidiness and cleanliness of the workbench, the tools and all the other equipment to be utilised.

A plentiful supply of clean rags or cotton waste should be at hand, as it is all too easy to transfer dirt and grit to vital working parts by using soiled rags.

TOOLS

For all dismantling and assembly work, use spanners, tools and extractors in good condition. Avoid the use of improvised or inferior equipment, which often results in a loss of time and is liable to damage the parts.

SEQUENCE OF DISMANTLING

When dismantling, take careful note of the sequence of removal of the various components, in order to

be able to reassemble them in the correct order. On no account mix the parts with similar ones belonging to other machines.

GASKETS

As a general rule, always use new gaskets. These should be smeared with grease. The use of adhesive jointing compounds is to be avoided, due to the difficulty of removing them once they have set.

BALL BEARINGS

The bearing tracks and balls must show a surface which is uniformly polished and bright. If signs of roughness or pitting are detected at any point, the bearing must be changed. Check that the cages, too, are in perfect condition.

If play is apparent after the bearing has been washed in clean paraffin and re-oiled, it is worn and should be discarded. Bear in mind, however, that the interference fit of the bearing in its housing tends to reduce the running clearance.

FITTING SHIMS

Carefully note the position of all washers and shims when dismantling and replace them when re-assembling. A list of washers and shims supplied for adjustment purposes is given at the back of this book.

POWER UNIT—SERVICING

ENGINE REMOVAL AND ROUTINE MAINTENANCE

REMOVING ENGINE UNIT

The fairings on each side of the machine must first be detached. These are secured by knurled screws. Disconnect the sparking plug cap and the low tension wire from the external ignition coil. (See Fig. 1.) This wire must be threaded back through its retaining bracket to be clear of the frame. Pull off the lighting wire which is clipped to the terminal behind the magneto stator plate. (See Fig. 2.) To disconnect the decompressor cable, depress the valve in the cylinder head with the fingers and guide the inner cable out from the loop in the end of the valve spring. Now unhook the cable nipple from the stop plate on the cylinder head.

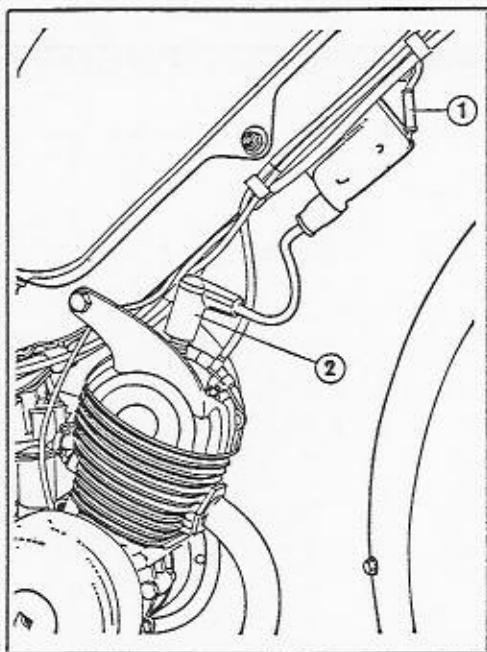

Fig. 1

1. Ignition low tension wire
2. Sparking plug cap

Turn off the fuel tap and disconnect the feed pipe at the carburettor end. It may be necessary to slide the feed pipe retaining spring clip along the pipe away from the carburettor before the pipe can be pulled clear. Loosen the carburettor stub screw and tilt the carburettor slightly towards the left-hand side of the machine. This will allow easier access to the screw which secures the mixing chamber cover. (See Fig. 3.) Remove this screw and carefully lift off the cover together with the throttle and enrichment valves. (See Fig. 4.) The carburettor may now be eased from its mounting stub.

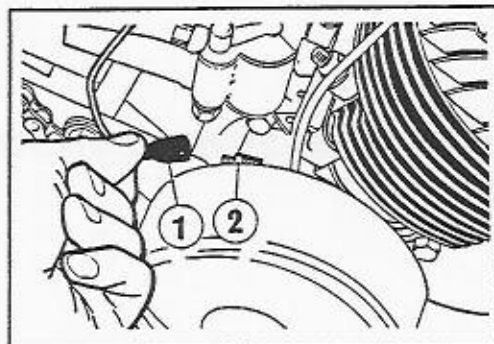

Fig. 2

1. Lighting wire
2. Lighting terminal

Loosen both the top and bottom engine mounting bolts; push the engine to its rearmost position in the belt adjustment slots and loop the drive belt off the bottom bracket pulley. (See Fig. 5.) Now push the engine forward in the slots until the lower mounting bolt is clear of the pedal chainwheel, remove the nut and washer and pull out the bolt. At this stage it will be preferable to unscrew the large nut at the exhaust port and take off the exhaust system

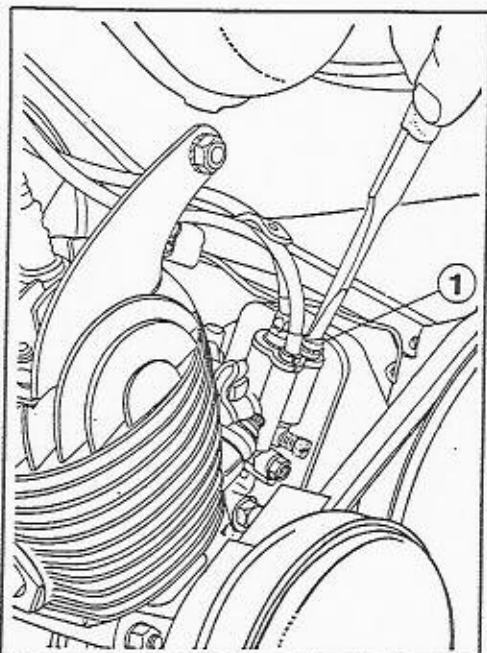

Fig. 3

1. Mixing chamber cover screw

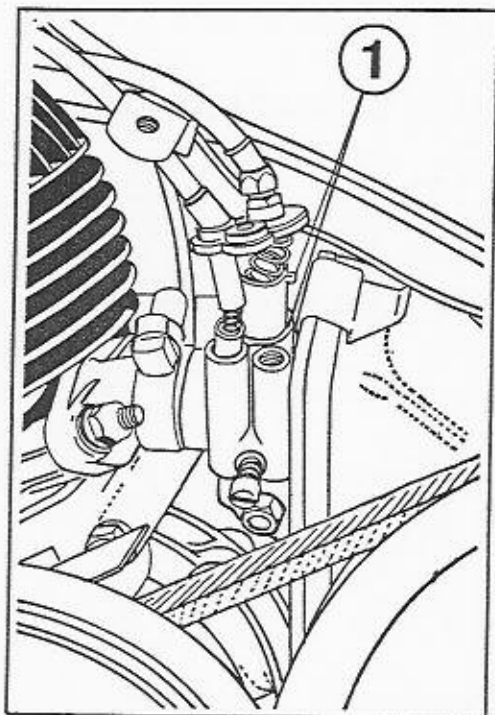

Fig. 4

1. Throttle valve guide and slot

complete. (See Fig. 6.) Support the engine by hand; remove the top mounting bolt and lower the engine to the bench. Note the tubular distance piece fitted between the lower engine plates.

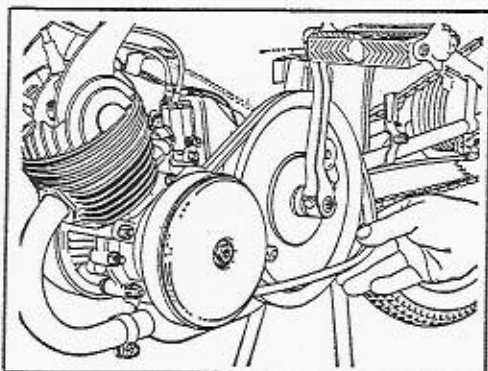

Fig. 5

- Removing the drive belt

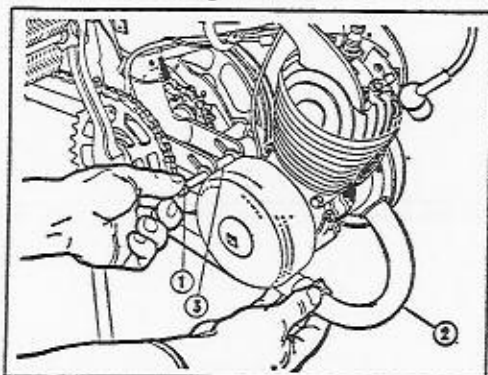

Fig. 6

1. Lower mounting bolt
2. Exhaust system
3. Tubular distance piece

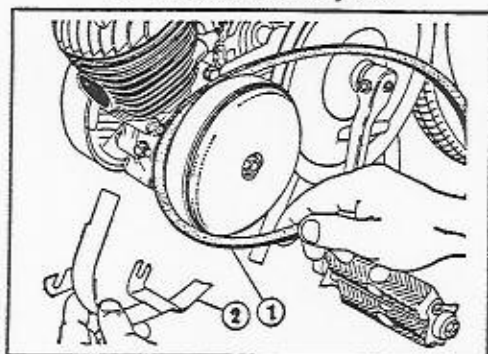

Fig. 7

1. Drive belt. 2. Belt guard

If it is required to remove the drive belt, loosen the two crankcase bolts which hold the belt guard, then remove the guard and the belt. (See Fig. 7.)

REFITTING ENGINE UNIT

Support the engine in the frame by means of the top mounting bolt, but do not tighten. Place the distance piece for the lower mounting bolt in position between the lower engine plates, replace the exhaust system complete and insert the lower mounting bolt. (Do not forget to fit a new copper-asbestos gasket in the exhaust port.) Tighten the exhaust pipe nut. The drive belt may now be refitted and tensioned. To adjust the belt tension, insert a suitable lever, such as a hammer handle, between the bottom bracket housing and the lower engine mounting bolt (see Fig. 8), and without using undue force, lever the engine forward by the required amount. Tighten both engine mounting bolts. When the belt is correctly tensioned, finger pressure on the belt midway

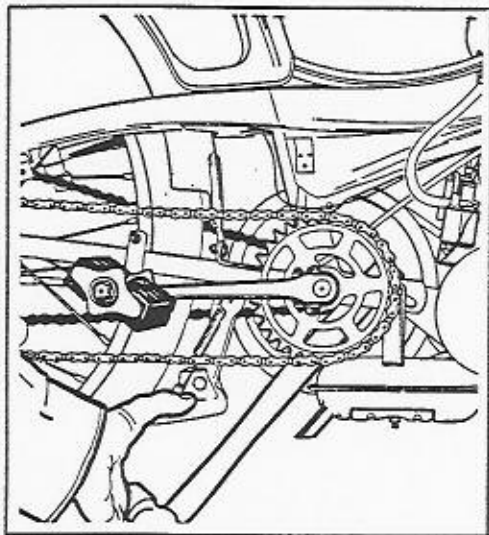

Fig. 8
Adjusting belt tension

between the pulleys should produce just a trace of up and down movement.

Replace the carburettor and refit the mixing chamber cover, together with the throttle and enrichment valves. (Note that the throttle valve has a small projection at the top which must engage correctly in the guide slot in the carburettor body, see Fig. 4.) Ensure that the carburettor is vertical and tighten the stub clip screw. Refit the fuel pipe.

Connect the lighting wire to the terminal behind the stator plate. Thread the ignition low tension wire through the retaining bracket on the frame and connect it to the ignition coil, then fit the sparking plug lead and the decompressor cable.

Re-check the tightness of all mountings, etc., and refit the fairings.

FITTING A NEW DRIVE BELT

Remove the fairings and loosen both engine mounting bolts. Slacken off the two crankcase bolts which secure the drive belt guard and remove the guard. Pull the engine back to its rearmost position in the adjustment slots and remove the belt, taking it off the bottom bracket pulley first. (See Figs. 5 and 7.)

Fit the new belt, placing it on the clutch pulley first. Adjust the belt tension as described in the section on refitting the engine to the frame. Replace the drive belt guard and fairings.

DECARBONISING

With any two-stroke, build up of carbon in the engine and exhaust system will cause a marked deterioration in performance.

In addition, if the exhaust system is obstructed so that the hot exhaust gases cannot freely escape, this will

have a detrimental effect on the life of the engine.

It is, therefore, most important that the work of removing the deposits of carbon is not neglected. This should be carried out as a matter of routine and not left until a fall off in power and performance makes it necessary.

DECARBONISING THE EXHAUST SYSTEM

At intervals of about 3,000 miles, or more frequently if the machine is used mainly for short runs, or stop and start riding, the deposits of carbon should be removed from the exhaust system.

Remove the exhaust pipe after unscrewing the large exhaust port nut and slackening the silencer clip. Scrape the carbon out of the pipe, using a suitable implement. Turn the piston to its lowest position and clean out the exhaust port. Take care to keep the dislodged carbon out of the cylinder.

The silencer is fitted with a removable cover plate. (See Fig. 9.) Remove the retaining nut and washer and prise off the plate, taking care not to damage or distort the joint faces. The carbon should now be scraped from the interior of the silencer, not forgetting the tail pipe

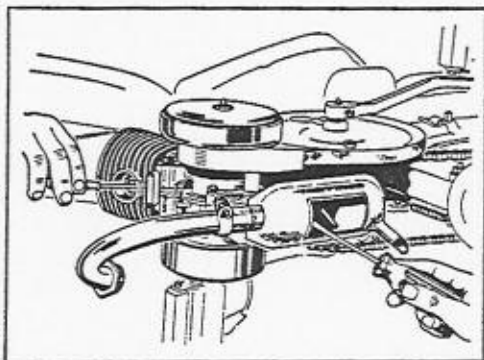

Fig. 9
Decarbonising the exhaust system

and the holes in the inlet pipe, which must be clear. When replacing the plate do not overtighten the nut. Always fit a new exhaust port copper-asbestos gasket when replacing the exhaust pipe.

DECARBONISING THE ENGINE

This does not require attention as frequently as the exhaust system but decarbonising should be undertaken at intervals of approximately 6,000 miles, dependent of course on the type of use that the machine receives.

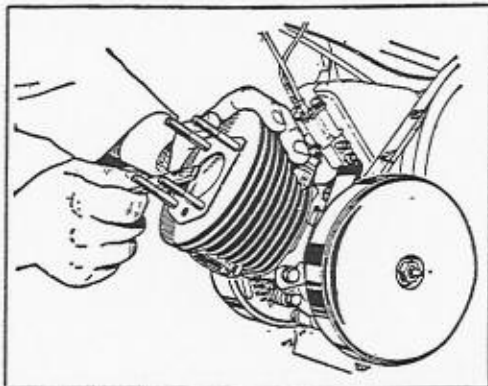

Fig. 10
Decarbonising piston crown

Remove the fairings, disconnect the sparking plug lead and the decompressor cable and take out the sparking plug. Remove the upper engine mounting bolt and the four cylinder head nuts and washers and take off the upper engine mounting brackets. The engine is now only supported by the lower mounting bolt and care should be taken to prevent it swinging too far forward and hanging on the carburettor cables. Now withdraw the cylinder head, taking great care not to lift the cylinder in the process and thus break the joint between the cylinder and the crankcase.

For the actual work of removing the deposits of carbon a soft metal

(copper, aluminium, etc.) scraper should be used. Hold the cylinder and turn the flywheel to bring the piston to the top of its stroke. Scrape the carbon from the crown of the piston. (See Fig. 10.) Turn the flywheel until the piston is at the bottom of its stroke. Clean out the carbon from the exhaust port. Scrape the carbon from the cylinder head combustion chamber.

Remove all traces of loose carbon from all the components, preferably with a jet of compressed air. When refitting the cylinder head, use a new gasket and tighten the head nuts alternately, a little at a time, to avoid any distortion. Refit the remaining components in the reverse sequence.

DECOMPRESSOR VALVE

Should the decompressor valve require attention, the cylinder head will have to be removed. It is recommended, therefore, that the valve is serviced as a matter of routine when decarbonising the engine.

To remove the valve, cut off the head of the spring retaining pin and remove it, taking care not to let the component parts fly apart. Push out the valve. Examine the seating sur-

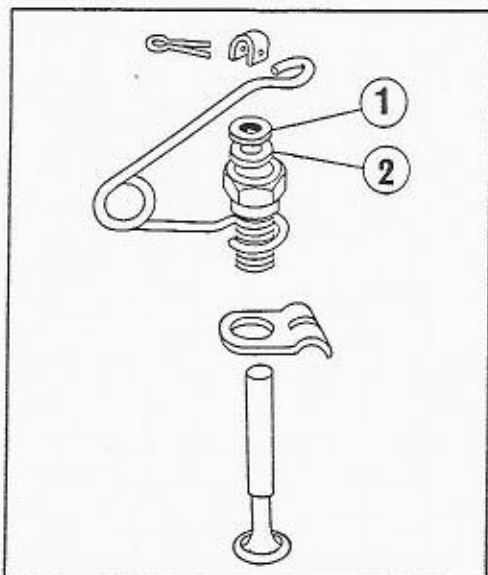

Fig. 11

1. Seal retaining washer
2. Decompressor valve seal

faces and if any pitting or burning is noticeable grind in the valve, using a fine grinding paste. Wash off all traces of grinding paste with paraffin or petrol. A plastic seal is fitted in the valve guide. If there is excessive leakage around the valve stem the seal must be replaced. (See Fig. 11.)

AUTOMATIC CLUTCH

The automatic clutch is really two clutches in one. The primary clutch is connected to the engine crankshaft and its operation is therefore governed by engine speed. The secondary clutch is coupled via the Vee-belt and the driving chain to the rear wheel and its operation depends on road speed. With the machine at rest, increasing the engine speed by opening the throttle causes the primary clutch to come into

operation and starts the machine moving. When a road speed of about 4 m.p.h. has been reached the secondary clutch also comes into effect and locks up the drive, eliminating any slip.

When the twistgrip is turned to the "neutral" position and the speed of the machine is brought below 4 m.p.h. the clutch drive disengages and the machine can come to a standstill with the engine idling.

Special Tools Available for Clutch Servicing

- 6200558 Clutch drum extractor.
- 6200569 Flywheel holding tool (webbing strap wrench type).
- or 6200567 Flywheel holding tool (screw operated steel band type).
- 6200548 Clutch drum nut wrench, 14 mm.
- 6200561 Clutch key positioning tool.
- 6200542 Circlip pliers, internal type.
- 6200543 Circlip pliers, external type.
- 6200571 Piston stop.
- 6200555 Grease nipple socket spanner with wooden handle.
- 6200651 Magnetic extractor, clutch washer.

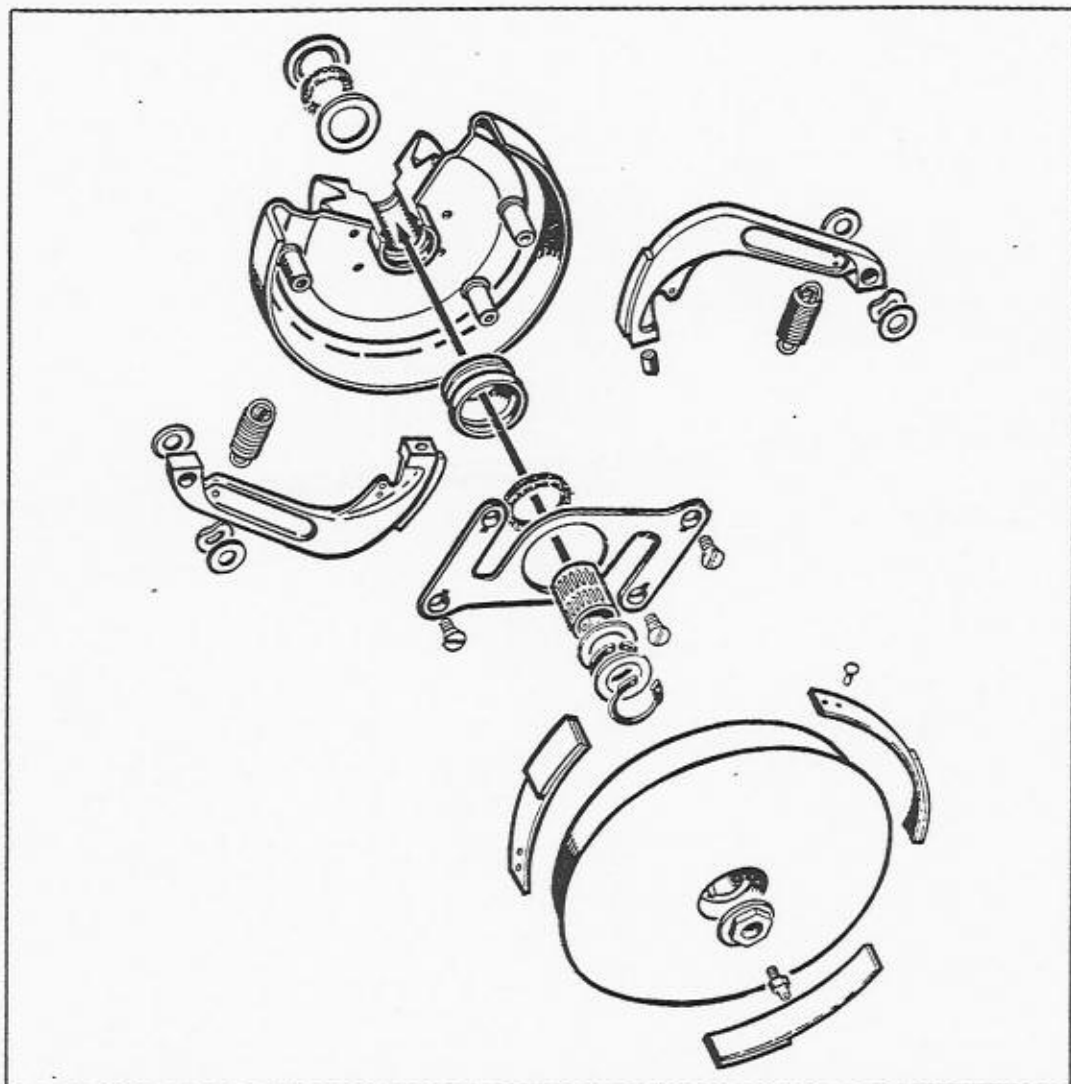

Fig. 12. Exploded view of the clutch

REMOVING CLUTCH DRUM

The clutch drum is fitted on a taper on the crankshaft. Prevent the crankshaft turning, preferably by holding the magneto flywheel with a strap wrench (see Fig. 13), or by using a piston stop screwed into the sparking plug aperture. Take out the central grease nipple, using a 6 mm. box spanner. With a 14 mm. spanner unscrew the clutch drum nut. Fit a thread protector on to the crankshaft thread and screw the clutch drum extractor fully into the hub. Tighten the extractor bolt. (See Fig. 14.)

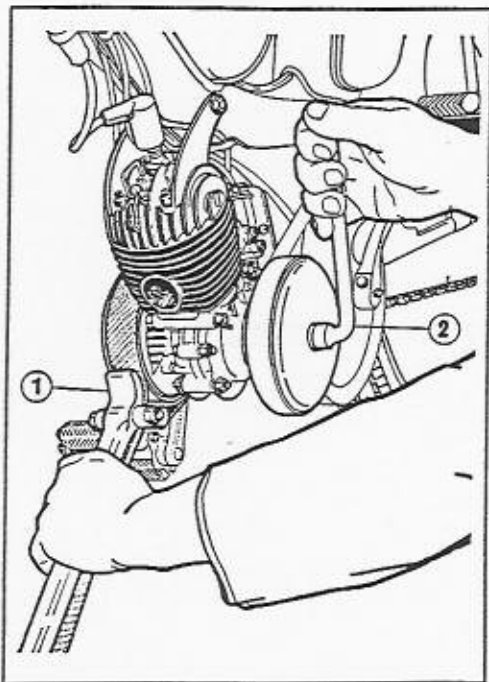

Fig. 13

1. Strap wrench 2. 14 mm. spanner

If the drum is not loosened by means of reasonable pressure on the bolt, tap the head of the bolt with a hammer and retighten, repeating this sequence until the drum is free. Remove the extractor, unscrew the thread protector and take

off the drum. Now remove the key from the shaft. (Note:—early production models were not fitted with a locating key in the crankshaft.)

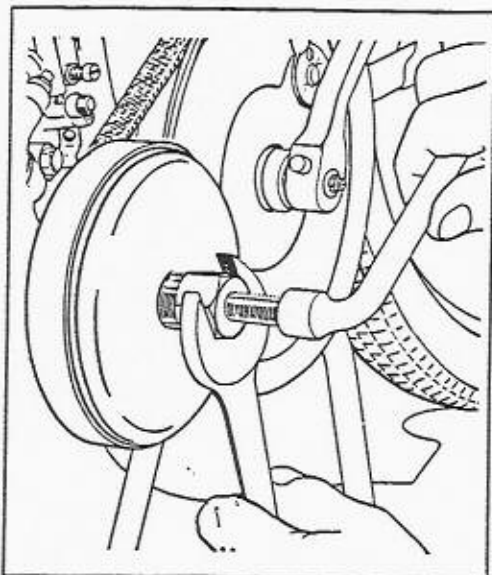

Fig. 14

Removing clutch drum

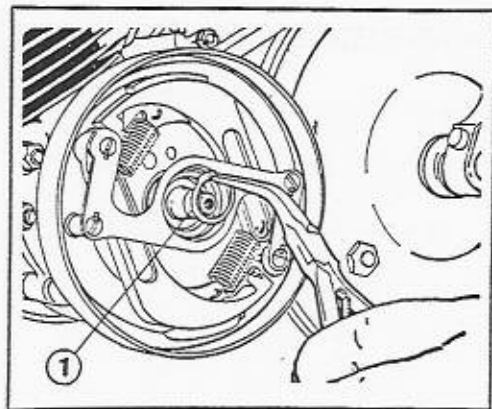

Fig. 15

1. Internal type circlip

REMOVING CLUTCH BODY

The clutch body is located on the crankshaft by circlips. Extended nose circlip pliers are required to remove them. (See Fig. 15.) The order of dismantling is as follows:—

1. Internal circlip, 22 mm. dia.
 2. Shims, as necessary, to adjust end movement of the clutch. 3. Thick locating washer. 4. External circlip, 15 mm. dia. 5. Another thick locating washer. 6. Needle roller cartridge. The clutch body can be pulled off the crankshaft with these last two in position.

REFITTING CLUTCH

Circlips should not be re-used. Thoroughly clean all parts, lightly grease the needle roller bearing and place it in position in the clutch hub (see Fig. 16), followed by a thick locating washer, the smaller circlip, a second locating washer and any thin shims necessary. Refit the larger circlip, ensuring that it is properly seated in its groove, centralise the smaller circlip in relation to the washers and push the clutch hub on to the crankshaft until

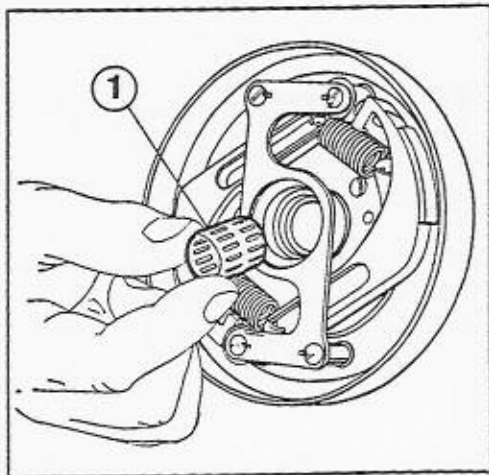

Fig. 16

1. Clutch needle roller bearing

the small circlip clicks into its groove on the shaft. Locate the clutch drum key, if fitted, in the crankshaft slot. Note that this key has a projection to prevent it being dislodged when fitting the drum. The key should be

fitted with the projection away from the crankcase. Replace the clutch drum and locknut and refit the grease nipple.

The clutch body should have approximately 0.1 mm. end float on the crankshaft. To adjust this, remove or add shims behind the large circlip. Shims of various sizes are listed on page 52.

RELINING CLUTCH DRUM

Remove the drum as detailed previously. File or grind off the rivet heads and remove the rivets with a pin punch. Take note of which way the leaf springs were fitted and fit the new ones in the same manner. Care must be taken when removing or fitting rivets that the drum is properly supported to prevent distortion. After the riveting operation, the drum should be placed in a lathe and the rivet heads machined level with the inside surface of the drum.

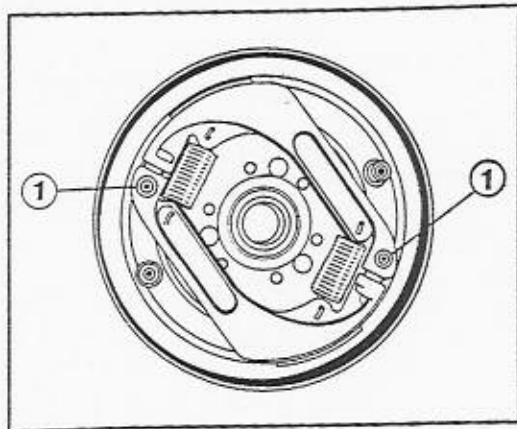

Fig. 17

1. Clutch shoe pivot pins

DISMANTLING CLUTCH BODY

Remove the clutch from the crankshaft. Lift out the locating washer and needle bearing from the clutch

hub. Take out the four countersunk screws from the shoe retaining plate and detach the plate together with the felt seal. Although the countersunk screws are locked in position by having a portion of the rim pressed into a recess in the plate, no difficulty will be experienced in removing them, using a properly ground screwdriver of the correct size. Now take particular note of the position of the plain and spring washers on the clutch shoe pivots. Remove these washers and lift off the shoes together. Disengage the clutch shoe springs. The felt retaining sleeve is a light press fit on the clutch hub. It should not be necessary to remove this for normal repair or overhaul. To replace the felt seal on the pulley side of the clutch, carefully cut away the tabs which retain the cap and lift out the cap and seal. Place the new seal in the cap, insert both into the clutch hub and lock them in position by punching over the rim of the recess.

REASSEMBLING CLUTCH

It will be noticed that the four pivot pins are irregularly spaced. Place one plain washer over each pivot which is clockwise from its closest neighbour. Assemble the

shoes and springs, fitting the springs in the holes which give the most tension. Fit the shoes over the pivots with the washers, so that the lining of each shoe is anti-clockwise from the pivot of the same shoe. (See Fig. 17.) Place one curved spring washer, followed by one plain washer, over the clutch shoe pivot (see Fig. 12), then replace the felt seal and fit the retaining plate. New countersunk screws should be used and locked after tightening in a similar manner to that employed originally. (See Fig. 18.)



Fig. 18
Locking countersunk screws

FLYWHEEL MAGNETO

Special Tools Available for Magneto Servicing

- 6200557 Magneto flywheel hub/cam extractor.
- 6200565 Flywheel nut key, 10 mm. square.
- 6200569 Flywheel holding tool (webbing strap wrench type).
- or 5200567 Flywheel holding tool (screw operated steel band type).
- 6200556 Ignition advance gauge.
- 6200571 Piston stop.
- 6200346 Coil centralising ring.

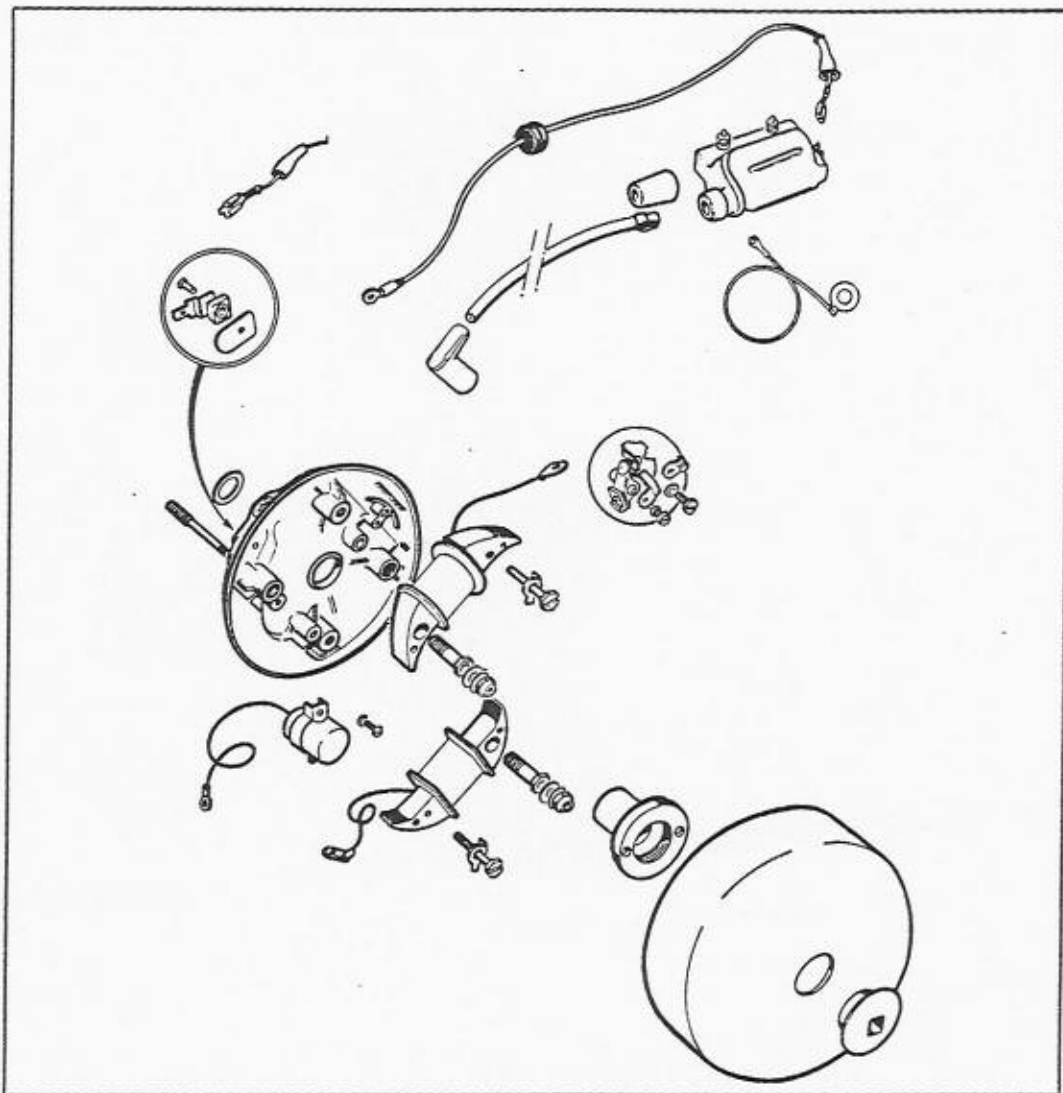

Fig. 19. Exploded view of magneto

REMOVING AND REPLACING FLYWHEEL

Hold the magneto flywheel, either with a strap wrench or by fitting a piston stop in the sparking plug aperture in the cylinder head, and with a 10 mm. square-ended key unscrew the central cap nut which has a LEFT-HAND thread. (See Fig. 20.) The flywheel can then be pulled off its register on the cam,

the cam itself remaining in place on the crankshaft. (See Fig. 21.) When refitting the flywheel, ensure that the pegs on the flywheel are properly located in the holes in the cam.

CONTACT BREAKER POINTS

To obtain access to the contact breaker, remove the flywheel as detailed above.

Check the condition of the points and if oily or dirty clean with a non-fluffy rag dipped in pure petrol or methylated spirit. If the points are blackened, they can be cleaned by inserting a strip of very fine glass paper between them. Close the points on to the glass paper and draw it through several times with the abrasive side towards each point in turn. Points that are slightly pitted may be refaced using a special contact file, but badly pitted or worn points should be replaced.

To check the contact breaker points gap, rotate the engine until the points are fully open and insert

a feeler gauge between them. To adjust, loosen the fixed contact locking screw and move the contact as required by inserting the blade of a screwdriver into the slot in the spring clip and twisting slightly in the required direction. Tighten the locking screw and re-check the gap. (See Fig. 22.)

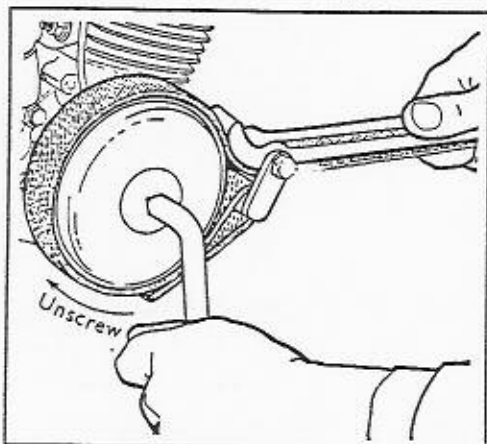

Fig. 20
Removing flywheel nut

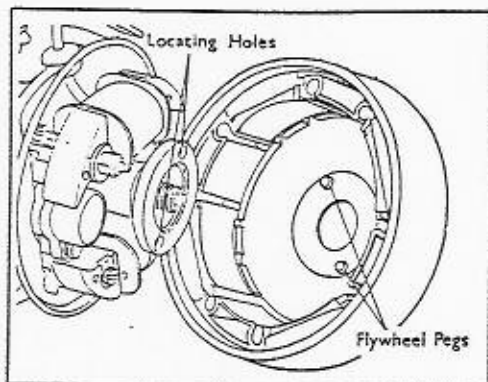

Fig. 21
Removing flywheel

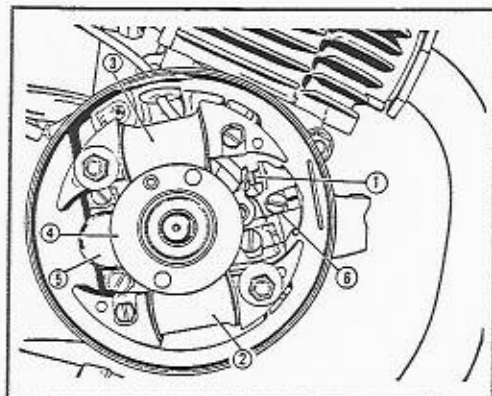

Fig. 22

- | | |
|------------------------------|--------------------------------|
| 1. Contact breaker points | 4. Cam |
| 2. Ignition low tension coil | 5. Condenser |
| 3. Lighting coil | 6. Fixed contact locking screw |

REPLACING CONTACT BREAKER

Remove the screw and washer and take off the three leads from the insulated terminal. Loosen the fixed contact locking screw and remove it, together with the spring clip. Take out the contact breaker. Ensure that the new contact breaker is perfectly clean and place it in position, locating the spindle peg in the drilled boss in the stator plate. Re-connect the three leads to the insulated terminal and fit the fixed contact locking screw, washer and spring clip. Make sure that none of the three leads is trapped between the contact breaker and stator plate and adjust the points gap to 0.016"–0.018".

MAGNETO TIMING

It should not be necessary to disturb the initial setting of the cam but if for any reason the cam has to be removed, the special extractor should be used, in conjunction with a crankshaft thread protector. (See Fig. 23.)

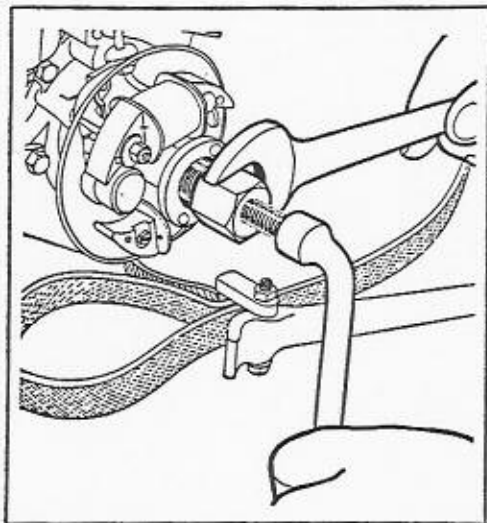

Fig. 23
Removing flywheel cam

Screw the body of the extractor fully home and tighten the central screw **WITHOUT USING UNDUE FORCE**. With a hammer, give the end of the screw a sharp tap, which should free the cam from the shaft. If not, repeat the process.

To retune the ignition when replacing the cam, take out the sparking plug and screw in its place the ignition advance gauge. Provisionally replace the cam and turn it until the contact breaker points are fully open. Check the points gap and, if necessary, adjust it to 0.016"–0.018". Remove the cam. Rotate the engine and, as it turns, the plunger in the centre of the tool will rise until at top dead centre it reaches its highest

point. (See Fig. 24.) Turn the engine back until the plunger has fallen by $\frac{1}{8}$ " (0.109") and keeping the engine from turning any further, replace the cam in such a position that the points are just beginning to open. Give the cam a sharp tap with a wooden implement to fix it on the taper and refit the flywheel.

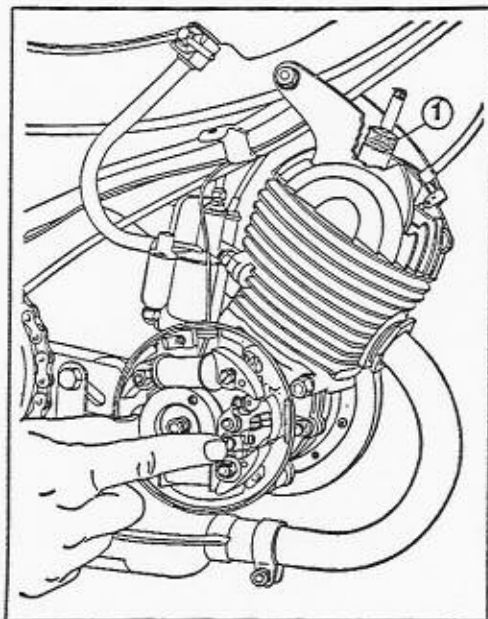

Fig. 24
1. Ignition advance gauge

REPLACING CONDENSER

Remove the two condenser fixing screws and washers and disconnect the condenser lead from the contact breaker insulated terminal. Remove the condenser.

When fitting the new condenser, make sure that the lead is run well away from the moving parts.

REPLACING COILS

Each coil is attached to the stator plate by a hollow screw and a hexagon screw with a slotted head. The stator plate itself fits over two

studs which project from the crankcase and protrude through the two hollow screws. Washers are fitted over the ends of these studs and self-locking nuts screw on to the studs and clamp the stator plate firmly to the crankcase.

The L.T. ignition coil can be removed without disturbing the ignition timing.

First disconnect the coil output lead from the contact breaker connection. Unscrew the self-locking nut (8 mm. spanner) and remove the washers from beneath it. The slotted hexagon screw is locked in place by a tab washer with the tab turned over one flat of the screw. Flatten out the tab washer and remove this screw. Take out the hollow screw and remove the coil from the stator plate.

The lighting coil can be removed in a similar manner, but due to the riveting of the output lead to the terminal on the stator plate, it is usually more convenient to remove the whole stator plate from the machine. The lead can then either be unsoldered from the terminal, or the terminal rivet drilled out, in which case a new terminal will be required when refitting.

When replacing coils, it is essential that they should be fitted correctly in order to provide a constant minimum clearance between their pole pieces and the flywheel. A coil centralising ring must be used to position them accurately.

The coils are assembled loosely on the stator plate, the centralising ring pushed over them and located on the four small tongues protruding from the threaded bosses on the stator plate. (See Fig. 25.)

Press the laminated pole pieces of the coils against the inside surface of the ring and tighten the coil screws. Fit the two self-locking nuts

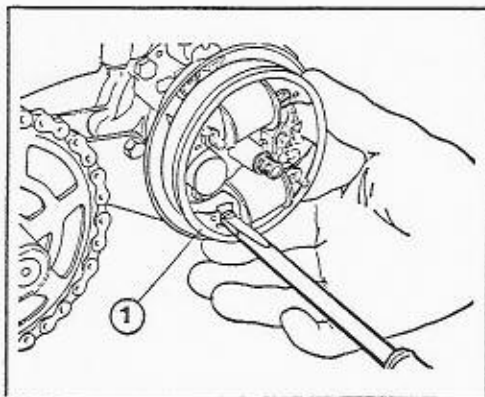

Fig. 25

1. Coil centralising ring

and their washers and tighten up the nuts. Fold over the tab washers to secure the two slotted screws. Remove the centralising ring by turning it slightly and pulling.

REMOVING STATOR PLATE

Remove the cam. Unscrew the two self-locking nuts on the coil pole pieces (8 mm. spanner) and take off the washers. Disconnect the wire from the lighting terminal at the rear of the stator plate. Dis-

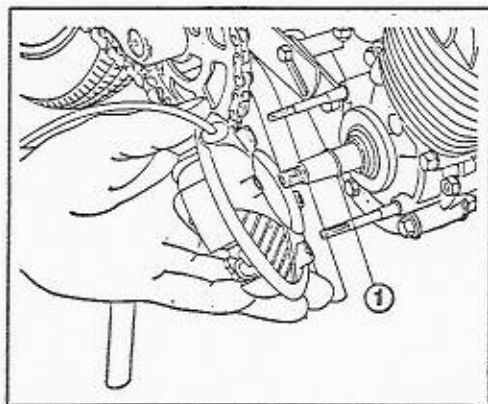

Fig. 26

1. Sealing ring

connect also the L.T. ignition wire from the external ignition coil and

pull the wire clear of the frame.

The stator plate will now pull off the mounting studs. Take care not to lose the small sealing ring fitted

to the crankshaft behind the stator plate. (See Fig. 26.)

Refit in reverse order to dismantling.

ENGINE DISMANTLING AND REASSEMBLING

Special Tools Available for Engine Servicing

- 6200559 Gudgeon pin extractor and fitting tool.
- 6200566 Crankshaft bearing extractor.
- 6200653 Dummy bearings, 15 mm. I.D.
- or 6200654 Dummy bearings, 16 mm. I.D.
- or 6200652 Crankcase/crankshaft gauge.
- 6200560 Piston ring clamp.

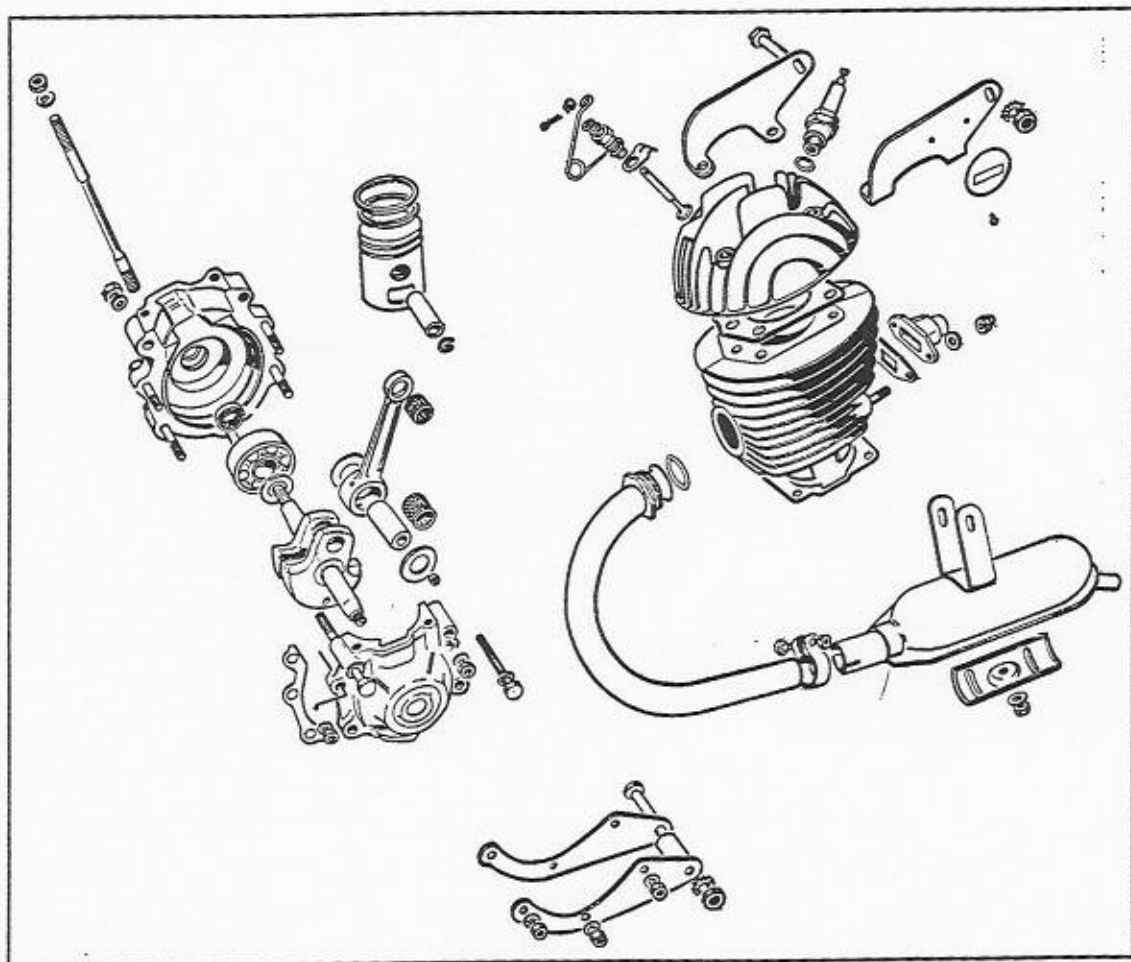

Fig. 27. Exploded view of engine

DISMANTLING CYLINDER AND PISTON

Remove the engine from the frame and remove the clutch and magneto as described in the appropriate sections. Take out the stator plate mounting studs. Unscrew the sparking plug and detach the cylinder head.

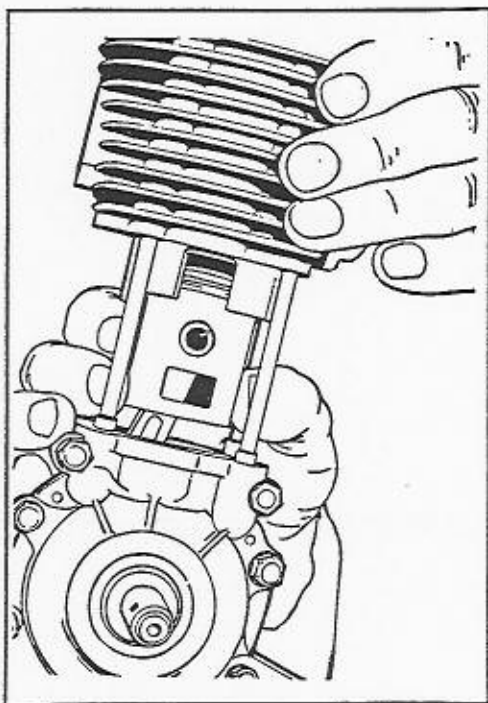

Fig. 28
Removing cylinder barrel

The cylinder barrel may now be lifted off (see Fig. 28), taking care not to impose any side loads which may bend the connecting rod. Remove the piston rings. (See Fig. 29.) Take out the gudgeon pin circlips (see Fig. 30) and after warming the piston to approximately 250°F., press out the gudgeon pin with the special gudgeon pin tool. (See Fig. 31.) It is essential that the correct tool is used for this operation

in order to prevent damage to the small end needle roller bearing. Remove the tool from the piston and push out the pilot drift with the fingers. The piston is now free. Remove the needle roller bearing to a safe place.

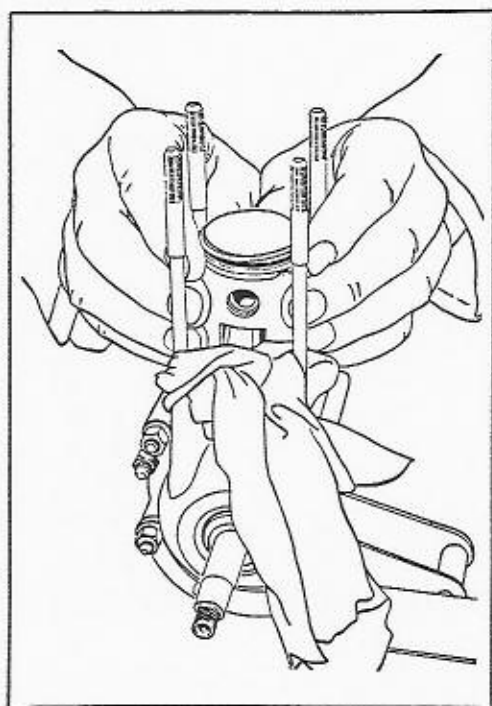

Fig. 29
Removing piston rings

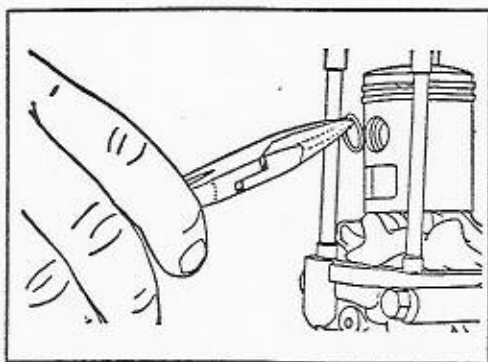

Fig. 30
Removing gudgeon pin circlips

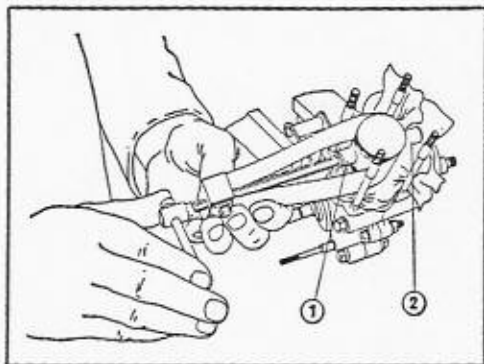

Fig. 31
Pressing out gudgeon pin
1. Pilot drift 2. Gudgeon pin

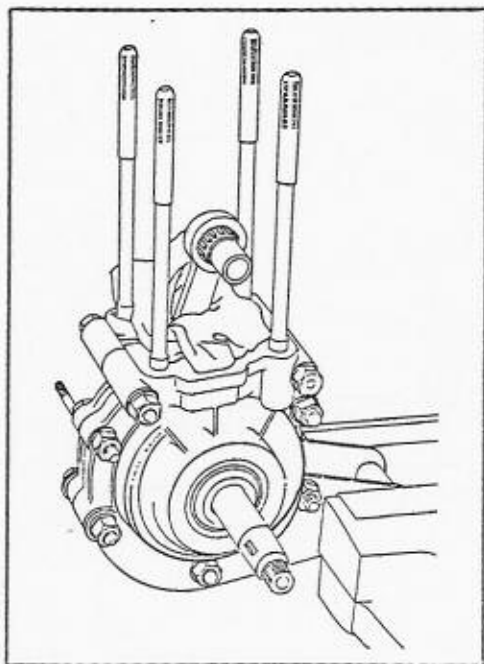

Fig. 32
Small end assembly, less piston

DISMANTLING CRANKCASE

Take out the seven bolts which hold the crankcase together and remove the engine plates. Note that the bolts which are threaded into the crankcase at the top have a coarser thread than the others. To free the crankcase from the main bearings, it will be necessary to heat

the crankcase to about 250°F. If a direct source of heat is used, i.e., a blowlamp or gas flame (see Fig. 33), care must be taken that the case is heated evenly. Tap the ends of the crankshaft on a wooden bench to free the crankcase halves. (See Fig. 34.)

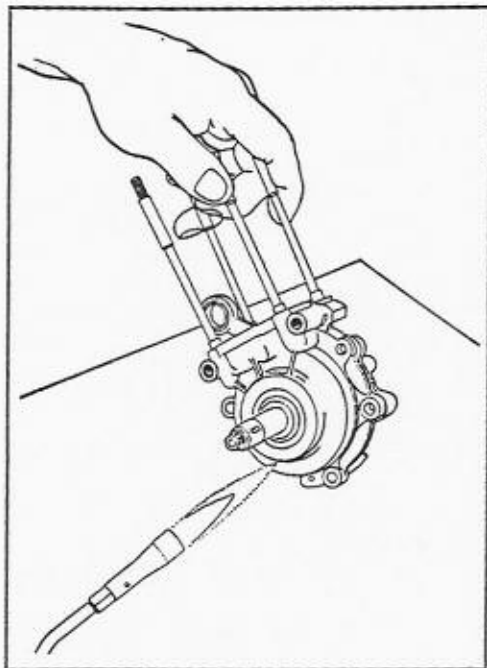

Fig. 33
Heating the crankcase

Prise out the crankcase oil seals and throw them away, as they may have been damaged by the heat of the dismantling operation.

REMOVING MAIN BEARINGS

If it is desired to remove the main bearings from the crankshaft, use the special tool as illustrated in Fig. 35. Take note of the position and thickness of any shims fitted between the main bearings and crankshaft webs.

It is not recommended that the repair of the crankshaft or big end

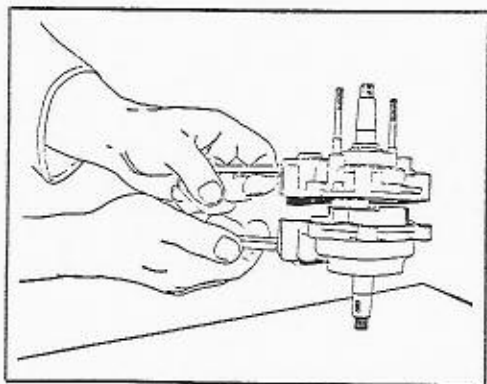

Fig. 34
Splitting the crankcase

should be attempted. This operation calls for special equipment which is normally possessed only by the Factory Service Department. An exchange crankshaft scheme is in operation, which provides guaranteed Factory Rebuilt units at an economical price.

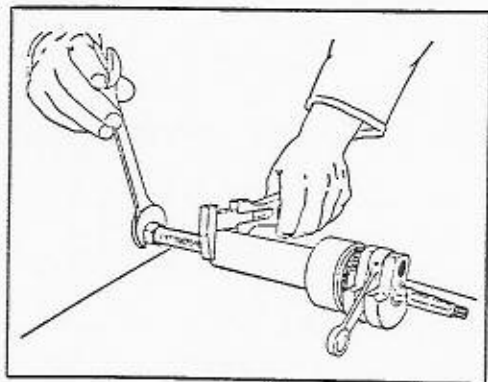

Fig. 35
Removing main bearing from crankshaft

REASSEMBLING CRANKCASE

If a new or replacement crankshaft is to be fitted, the end float of the shaft must be checked and adjusted, if necessary. The most convenient way of doing this is to obtain a pair of dummy bearings which are a sliding fit on the shaft and in the crankcase, but are of the exact width of the orthodox bearings. These are

obtainable from our Spare Parts Department. Mount the crankshaft in the crankcase using the dummy bearings and fit shims between the crankwebs and bearings until the required end float is obtained, i.e., .004" approximately.

Do not forget to allow for the thickness of the crankcase gasket and, if possible, distribute the shims to ensure equal thickness at each side.

When the end float has been adjusted, the main bearings may be assembled on to the crankshaft in the following manner. Place a piece of metal $\frac{5}{16}$ " thick between the crankwebs and support the metal on a vice as shown in Fig. 36. Check that the correct shims are in place and use a piece of tube of about $\frac{1}{2}$ " inside dia. to drive the bearings on to the shaft. Force should only be applied to the inner race of the bearing.

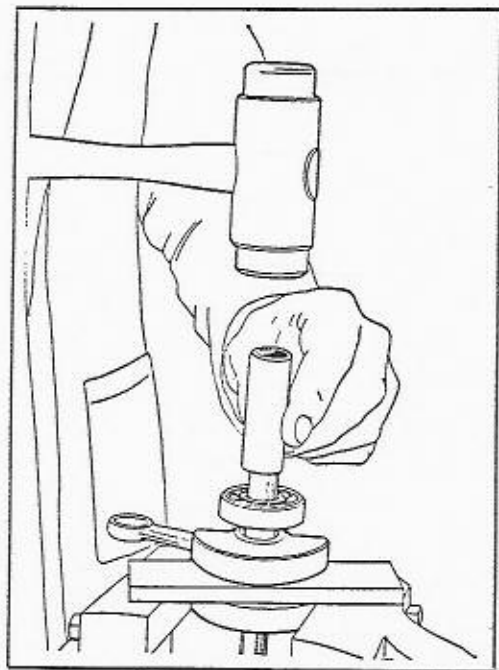

Fig. 36
Fitting a main bearing

Slide the new oil seals on to the crankshaft, making sure that the "lips" of the seals are outwards (away from the crankwebs). Take care not to damage the seal. Apply clean oil to the main and big end bearings. Warm up one half of the crankcase to about 250°F. and fit the crankshaft as quickly as possible. (Make sure it is the correct way round.) Place a new crankcase gasket in position on this half, held by a little grease if necessary, warm up the second half of the crankcase and fit the two halves together.

Do not forget the lower engine mounting plates when putting in the crankcase bolts. Tighten up the bolts evenly a little at a time. Do not overtighten.

PISTON SIZES

Before proceeding with the assembly of the piston on to the connecting rod, a few words are called for on the subject of piston sizes. To achieve the long life for which these engines are noted, very close tolerances are employed when fitting the piston to the cylinder. It would be impractical to manufacture pistons and cylinders to such fine limits as to make them all interchangeable, therefore, each piston is exactly matched to the correct cylinder at the Factory. If a replacement piston only is required, it is necessary for the cylinder to be returned to the Factory, where it will be measured and fitted with a new piston of the correct size.

REFITTING PISTON

Continuing the assembly of the engine unit, oil the small end needle roller bearing and place it in position in the connecting rod eye. Then

place the piston in position, making sure it is the right way round, i.e., with the small square cutaway in the skirt to the rear. Insert the long pilot drift of the gudgeon pin tool as a temporary gudgeon pin to align the assembly. Warm the piston and press in the gudgeon pin with the special tool, at the same time pushing out the temporary pin, thereby maintaining the alignment and preventing damage to the bearing. Fit new circlips, ensuring that they are properly located in their grooves.

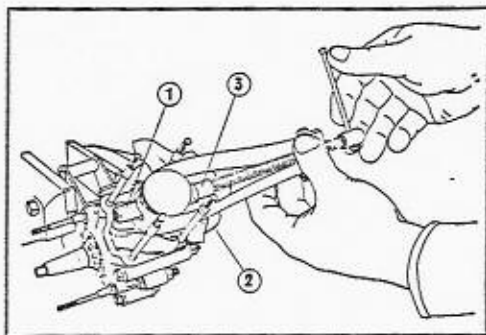

Fig. 37

Refitting gudgeon pin

1. Long pilot drift 3. Short pilot drift
2. Gudgeon pin

PISTON RINGS

Before refitting the piston rings, the gaps must be checked and adjusted if necessary by the following method to the clearance shown in the Technical Data.

Place the piston ring in the cylinder bore and ensure that it is absolutely square to the axis of the cylinder by pushing it half an inch or so down the bore with the piston. Check the gap between the ends of the piston ring with a feeler gauge. (See Fig. 38.) If the gap is too small, file the ends of the ring carefully and re-check.

If the gap is too large, new piston rings must be fitted, not forgetting, of course, to check the gap of the

new rings. Should the gap of even new rings be too large, a slightly oversize ring of 39.1 mm. diameter is available from our Spare Parts Department. When the gap of both rings is satisfactory, refit the rings to the piston.

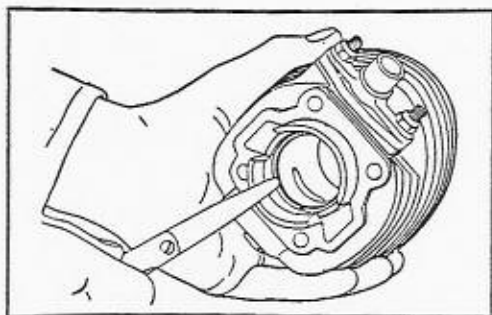

Fig. 38
Checking the piston ring gap

REFITTING CYLINDER

Place in position a new cylinder base gasket, check that the rings are located in relation to the pegs, oil and refit the cylinder. A piston ring clamp is available, if required, to facilitate this operation.

When the cylinder is in position, check that the piston does not protrude above the top face of the cylinder at "top dead centre." The edge of the piston must be level with the top face of the cylinder. Shims are available to fit beneath the cylinder to adjust the height, if necessary.

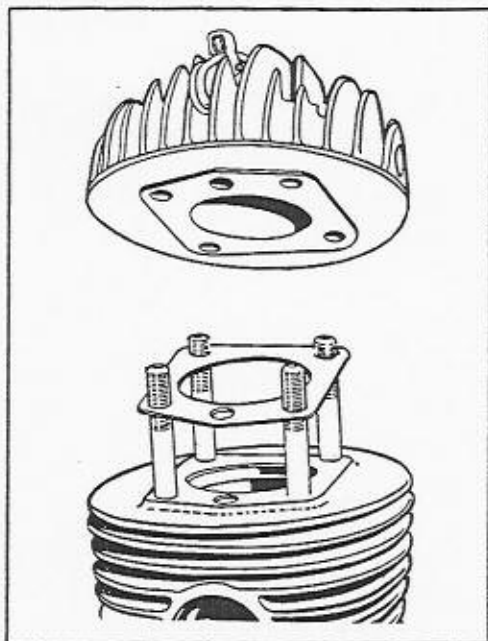

Fig. 39
Refitting cylinder head and gasket

Replace the cylinder head, using a new gasket. Ensure that the hole in the gasket for the decompressor outlet is in line with the hole in the cylinder. (See Fig. 39.) Do not forget the upper mounting plates. Tighten the cylinder head nuts evenly, a little at a time, in order to prevent distortion.

The clutch and magneto may now be replaced and the engine refitted to the frame as described in the appropriate sections.

FUEL SYSTEM

REMOVING CARBURETTOR

Make sure that the petrol tap is in the "OFF" position and detach both fairings. Disconnect the fuel feed pipe and loosen the nut on the carburettor stub clip. Tilt the carburettor towards the left-hand side

of the machine and remove the screw which secures the cover of the mixing chamber. (See Fig. 3.) Lift off the mixing chamber cover, together with the throttle and enrichment valves and slide the carburettor off the inlet stub.

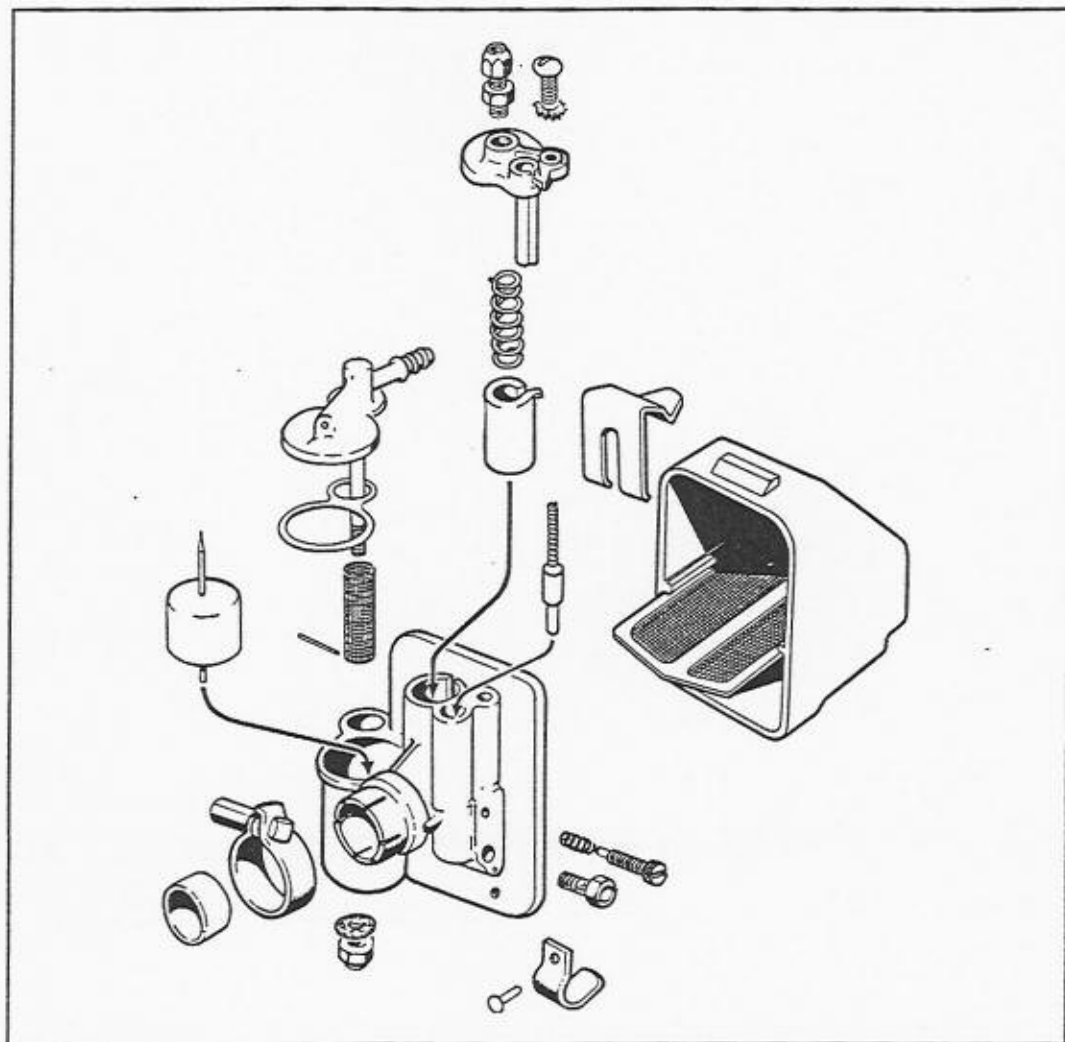

Fig. 40. Exploded view of carburettor

REFITTING CARBURETTOR

Push the carburettor on to the inlet stub and replace the mixing chamber cover and the throttle and enrichment valves. The small projection at the top of the throttle valve must engage in the guide slot in the carburettor body. (See Fig. 4.) Tighten the mixing chamber cover screw, make sure that the carburettor body is vertical and tighten the nut of the stub clip. Replace the fuel feed pipe and the fairings.

DISMANTLING CARBURETTOR

Remove the carburettor from the machine as described above and unclip the air filter. Slide the filter screen from the plastic body. Unscrew the cap nut at the bottom of the fuel filter chamber and remove the float chamber cover, the float and the fuel filter gauze. Screw out the main jet and the throttle stop screw. (See Fig. 41.) No further dismantling is necessary to carry out normal cleaning, but the following parts are

detachable should the need arise. Air cleaner clips, stub fixing clip and screw and the plastic insulation sleeve in the outlet of the carburettor.

To detach the throttle valve from its cable, compress the valve spring until the cable nipple can be released from its recess in the valve. The enrichment valve may be detached by loosening the clamp screw at the small handlebar lever and pulling the inner cable through the outer.

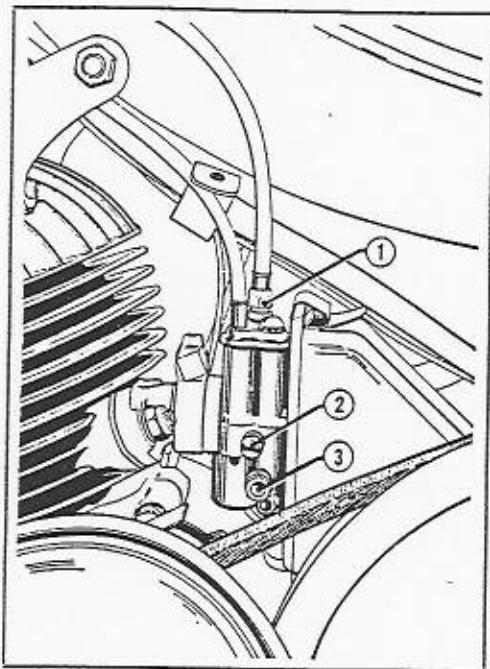

Fig. 41

1. Throttle cable adjuster
2. Throttle stop screw
3. Main jet

REASSEMBLING CARBURETTOR

All components should be thoroughly cleaned in petrol and dried with compressed air, if possible. Ensure that all drillways and jets are absolutely clean.

Replace the float (point uppermost) and the fuel filter gauze in their respective chambers (see Fig. 42) and fit the float chamber cover, using

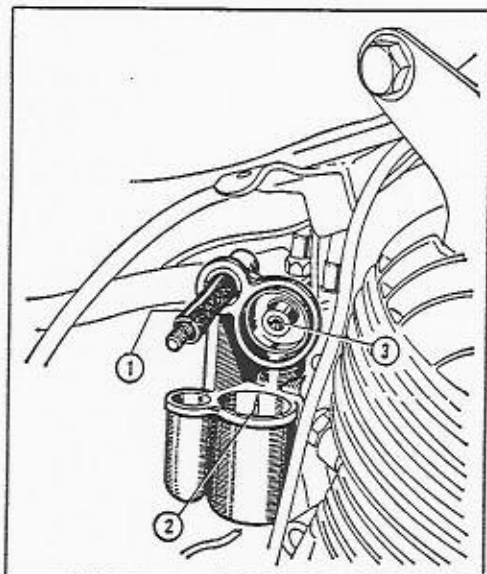

Fig. 42

1. Fuel filter gauze
2. Float needle
3. Float needle seat

a new gasket and a fibre washer under the cap nut. Do not over-tighten the cap nut. Refit the main jet and throttle stop screw and clip on the air cleaner after replacing the gauze screen.

CARBURETTOR ADJUSTMENT

The only adjustment normally required on this carburettor is to the throttle stop screw, which controls the "tick-over" speed of the engine. This should be set at the point where the engine runs at the lowest speed possible consistent with reliability. Screwing in the throttle stop screw (2, Fig. 41) increases the "tick-over" speed, whilst unscrewing it will decrease the speed.

Mixture strength at speeds above "tick-over" is controlled by the size of the main jet. In the unlikely event of adjustment being required to the mixture, alternative sizes of main jet are available, i.e., No. 18, No. 19 and No. 21; No. 20 being the standard size. The lower numbers pro-

vide a weaker mixture and the No. 21 a richer mixture. Before any alteration is made to the jet sizes, it must be ascertained that the fault does not lie elsewhere; for example, float damage, a tilted carburettor, blocked drillways or poor joints causing an air leak, will all affect mixture strength.

FUEL TAP

The fuel tap is fitted with a readily replaceable seal. (See Fig. 43.) To change the seal, drain the fuel tank, unscrew the seal retainer and lift out the old seal, using a penknife or other sharp pointed instrument.

Thoroughly clean out the fuel tap and fit the new seal, making sure that the seal is correctly located on the spigots inside the tap. Before refitting the rotor and retainer assembly, inspect the seating face of the rotor for burrs or other damage and rectify if necessary.

A gauze filter is fitted to the fuel tap. Should the fuel filter require cleaning, unscrew the tap from the fuel tank, wash in clean petrol and blow through with compressed air in the reverse direction to normal flow.

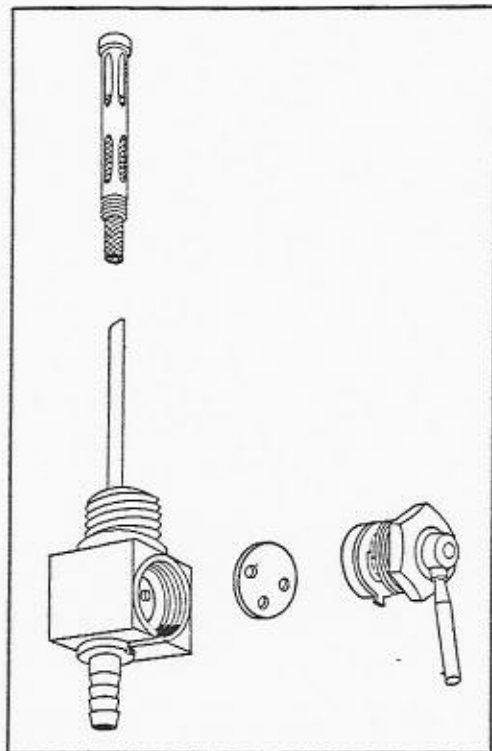

Fig. 43
Exploded view of fuel tap

A fuel tap of different appearance to that in Fig. 43 is fitted to some machines, but the method of repair and operation is identical.

TRANSMISSION—SERVICING

REMOVING BOTTOM BRACKET PULLEY AND AXLE

Detach both fairings and remove both chains, slacken the engine mounting bolts and loop the drive belt off the bottom bracket pulley. Take out the right-hand crank cotter pin (see Fig. 45) and remove the crank and chainwheel. After the

circlip and washer have been removed, the crank axle may be pulled out from its bearings, together with the pulley assembly and sprocket. Take particular note of the positions and sizes of the packing washers. They will need to be replaced in the correct positions to maintain the required degree of "end float" on the shaft.

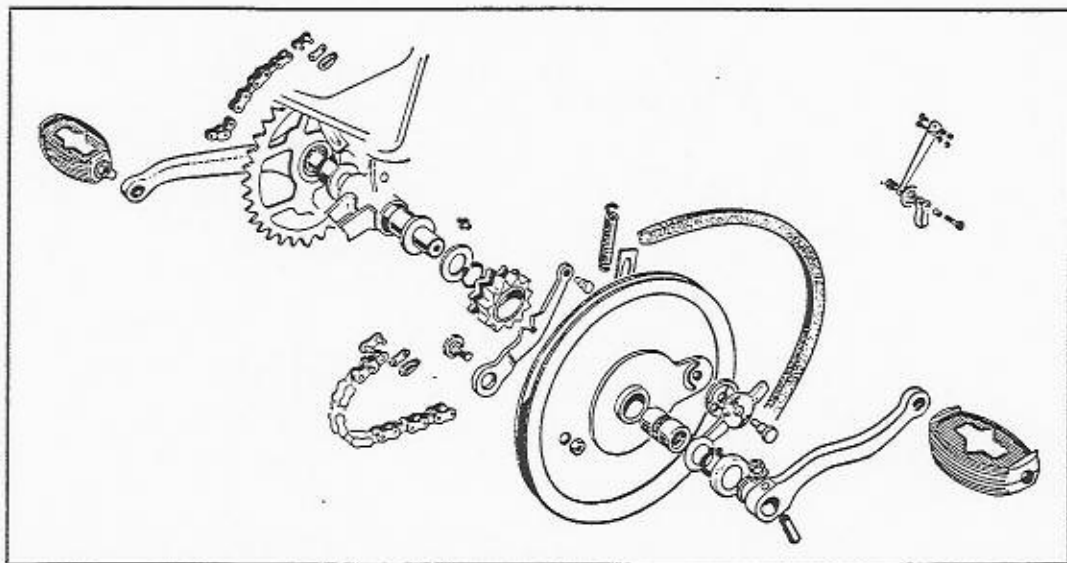

Fig. 44
Exploded view of bottom bracket assembly

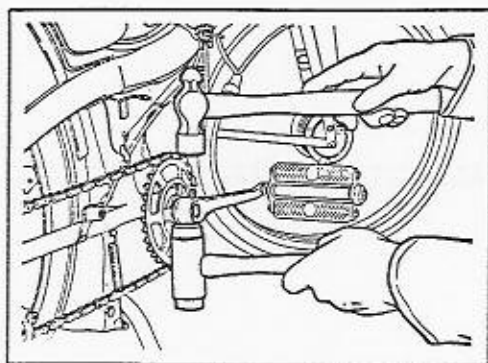

Fig. 45
Removing crank cotter pin

REPLACING BOTTOM BRACKET AXLE BEARINGS

The plain bearings which support the bottom bracket axle are a press fit in the frame and are made of a special self-lubricating material for which no routine maintenance is required. If occasion arises to replace these bearings, they must be reamed to size (16 mm.) after being pressed into the frame.

DISMANTLING BOTTOM BRACKET PULLEY

Continue the dismantling operation as follows:—Remove the left-hand crank cotter pin and crank. Slide off the distance tube from the crank axle and pull off the cap, which is lightly pressed on to the pulley hub. (See Fig. 46.) Remove the circlip and washer and then the pulley assembly complete can be

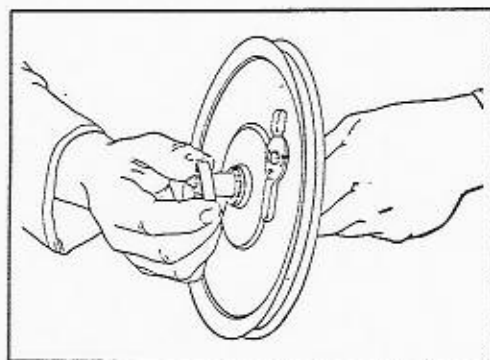

Fig. 46
Removing pulley hub cap

removed from the axle. Note the special shape of the circlip remaining on the axle.

The drive sprocket is a free running fit on the hub of the pulley, retained in position by the 33 mm. O.D. washer which is fitted to the bottom bracket axle between the frame and the pulley. The sprocket may be either of two types, reversible or non-reversible, easily differentiated by the fact that the drive chain will fit either set of teeth on the reversible sprocket, but only one set on the non-reversible. The non-reversible sprocket can, there-

fore, only be fitted one way, i.e., with the wider teeth towards the pulley.

To transmit the drive from the pulley to the sprocket a locking lever is employed, operated by a turnbutton on the outside of the pulley. (See Fig. 47.) To dismantle the locking lever, remove the nut on the outside of the pulley, take out the bolt and prise the spring off the peg on the turnbutton. (See Fig. 48.)

REPLACING BOTTOM BRACKET PULLEY BEARINGS

The pulley rotates about the axle on two needle roller bearings, which are replaceable if necessary. Use a suitably shaped drift to drive the old bearings out of the pulley hub. (See Fig. 49.) On no account must bearings which have been removed

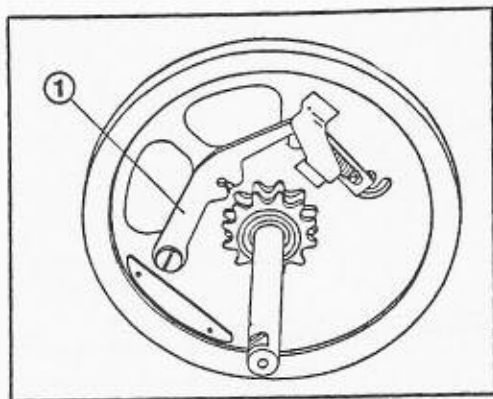

Fig. 47

1. Drive locking lever

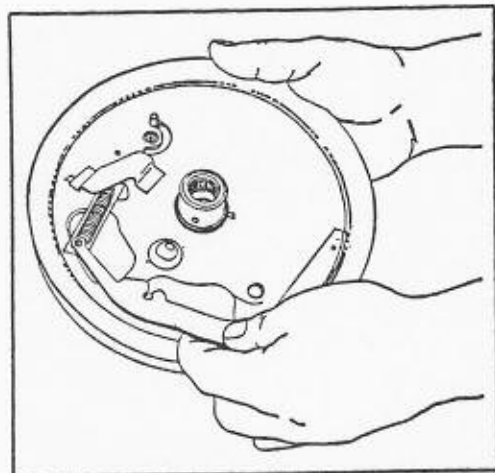

Fig. 48

Removing drive locking lever assembly

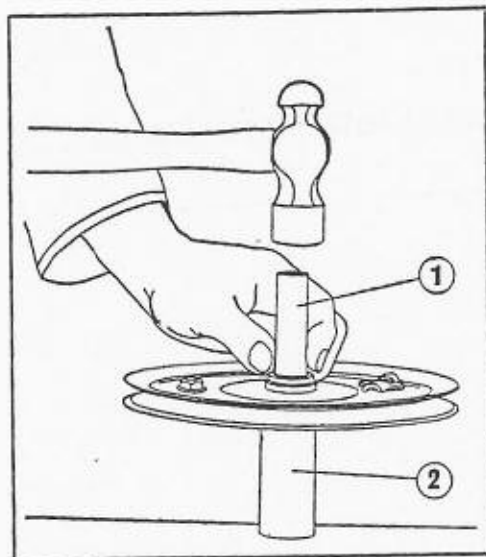

Fig. 49

1. Drift 2. Tubular support

be re-used. Two very important conditions must be observed when pressing in the new bearings. Firstly, the pressure required to fit the bearings in the hub must be applied only to the thick edge of

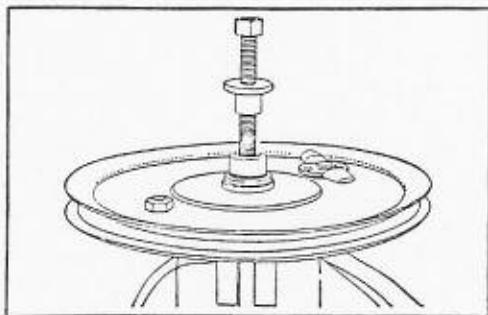

Fig. 50

Drawbolt arrangement for fitting pulley needle roller bearings

the bearing shell, i.e., the end with the maker's identification numbers embossed. (See Fig. 50.) Secondly, the bearing on the frame side of the pulley must be recessed inside the pulley hub a distance of 1.5 mm. to provide clearance for the middle circlip.

REFITTING BOTTOM BRACKET AXLE

Fit the specially shaped circlip in the middle groove on the crank axle and place the largest diameter washer next to the circlip, towards the longest side of the axle. Insert the shaft in the frame, with the washer and circlip to the left side of the frame. Place a packing washer on to the axle on the right side of the frame, followed by a circlip. There should be a slight amount of "end float" on the axle, i.e., approximately .004". Should it be necessary to adjust the "end float," alternative washers of different thickness are available, as listed on page 52. The right-hand crank may now be refitted.

REASSEMBLING BOTTOM BRACKET PULLEY

Refit the locking lever to the pulley, locking the nut on to the fulcrum bolt by lightly centre punching the threads in a similar manner to

that employed originally. Fit the sprocket. Slide the pulley on to the crank axle, holding the engine forward to give sufficient clearance. Fit the packing washer, circlip, hub end cap, tubular distance piece and pedal crank, in that order. Loop the drive belt on to the pulley and tension the belt as described on page 10. Refit both chains. Ensure that the needle bearings are adequately lubricated and replace the fairings.

CHAIN ADJUSTMENT

First put the machine on its stand and rotate the rear wheel to check the drive chain for slack. You will find that it is least slack at one particular spot, and chain adjustment must be carried out at this position.

To adjust, loosen the rear wheel spindle nuts and the brake arm wing nut and slacken right off the brake adjustment. Slacken the pedal chain by loosening the two bolts holding the jockey wheel arm. Then with a 12 mm. spanner turn each chain adjuster by an equal amount, moving the wheel backwards or forwards in the slotted chain lugs until $\frac{1}{2}$ " to $\frac{3}{4}$ " up and down movement is possible at the centre of the bottom chain run. (See Fig. 51.) Partially tighten the

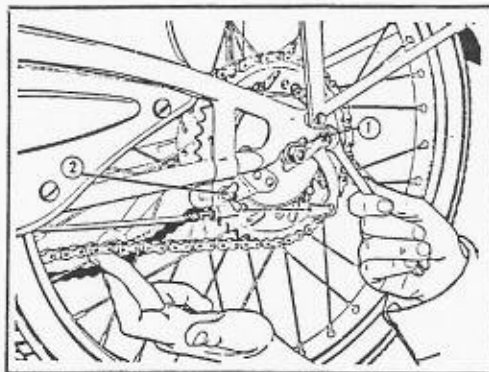

Fig. 51

Adjusting drive chain

1. Chain adjusting nut
2. Brake arm wingnut

wheel spindle nuts and check the wheel alignment. (See Fig. 52.) If this is correct, tighten the spindle nuts and the brake arm wing nut and adjust the brake. Set the pedal chain to its tightest spot and adjust the jockey wheel to produce $\frac{1}{2}$ " to $\frac{3}{4}$ " vertical movement at the centre of the bottom chain run.

On the Runabout, the rear brake plate is prevented from rotating by a fixed stop on the frame.

CHAIN LUBRICATION

It is not sufficient merely to put oil on a dirty chain. By far the best way to tackle this job is to remove the chains and wash them thoroughly in a bath of clean paraffin, using a stiff brush. Then wipe dry.

Check each chain for wear at this stage by placing it on a level surface alongside a rule and stretching it tight. 23 complete pitches (distance between centres of adjacent rollers) will come to the $11\frac{1}{2}$ " mark on the rule when the chain is new. When the chain wears to a measurement of $11\frac{3}{4}$ " for 23 pitches it should be replaced.

Immersion in a tin of warm SAE 50 grade oil for 15 minutes or so will allow the lubricant to soak right into

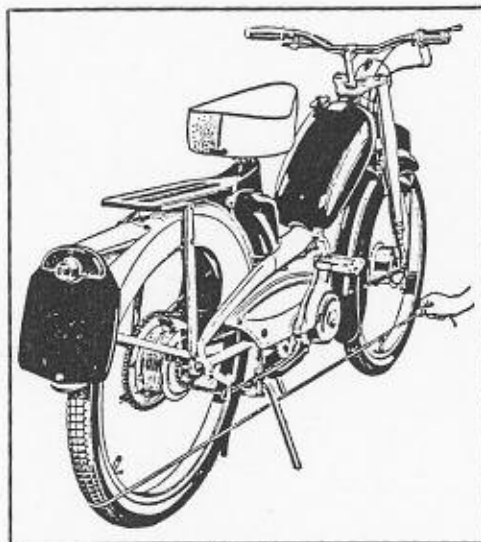

Fig. 52
Checking wheel alignment

the bearing surfaces. Warm the lubricant by standing the tin in very hot water. When the chain is thoroughly soaked, remove it and hang it up to drain off all surplus lubricant. Clean the sprockets before refitting the chain.

It is important when replacing a chain to make sure that the spring clip on the connecting link has its closed end pointing in the forward direction of chain travel.

FRAME AND CYCLE PARTS—SERVICING FRONT WHEEL

REMOVING AND REFITTING FRONT WHEEL

Support the front of the machine by placing a box under the engine. Slacken off the front brake adjuster and, on hub brakes, remove the cable from the brake arm. If a speedometer is fitted, disconnect the cable from the drive unit. Loosen the wheel spindle nuts and withdraw

the wheel from the forks.

On the Automatic Moped, ensure that the brake plate peg engages correctly with the slot in the fork and when refitting the wheel. (See Fig. 54.)

Before finally tightening the spindle nuts check that each end of the spindle is fully home in the slots and that the wheel rim is equidistant from the fork leg at each side.

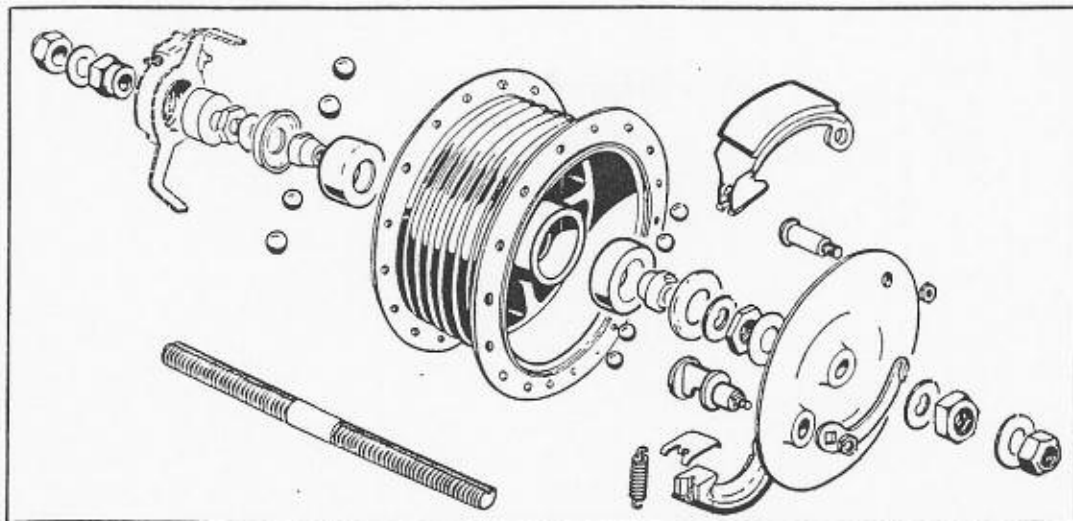

Fig. 53. Exploded view of front wheel brake hub

ADJUSTING FRONT WHEEL BEARINGS

The front wheel is fitted with cup and cone type bearings which are adjustable to compensate for wear. To carry out adjustment of the Automatic front hub, first remove the

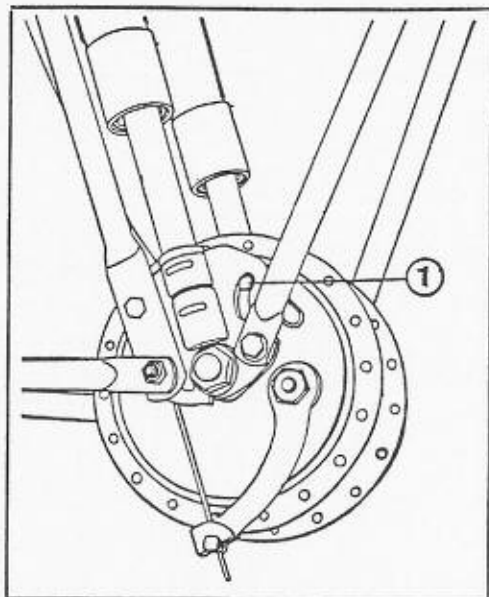

Fig. 54
1. Brake plate peg

wheel from the machine as described above and take off the left-hand spindle nut and washer, the spigotted nut and the speedometer drive unit or spacer, whichever is fitted. Slacken off the left-hand cone locknut, pull the keyed washer behind the nut away from the bearing cone, screw the cone in or out for adjustment and tighten the locknut. The adjustment is correct when there is

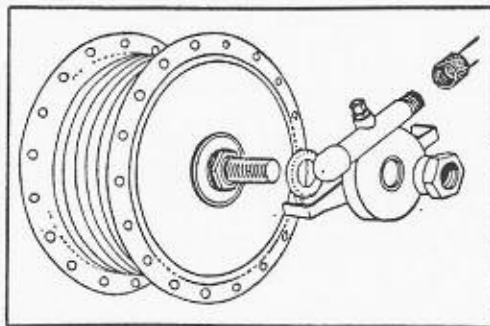

Fig. 55
Fitting the speedometer drive unit

just the slightest trace of sideways play detectable at the wheel rim when the wheel is refitted to the machine and the spindle nuts tightened. If a speedometer is fitted, be

sure that the drive unit is in the correct position to enable the cable to be fitted before tightening the spigotted nut. (See Fig. 55.) RM6 front hubs are adjusted in a similar manner, except that no locknuts are fitted to the bearing cones.

REPLACING FRONT WHEEL BEARINGS (RM4)

With the wheel removed, take off the brake plate and speedometer drive (or spacer), remove one cone locknut and screw off the cone. Withdraw the spindle from the opposite side, taking care not to loose any of the ball bearings as the cones are removed. Gently prise out the dust covers at each side of the hubs and tap out the bearing cups, using a copper or brass drift from the opposite side of the hub. Ensure that the bearing cups are tapped out squarely, in order to prevent them from binding in the hub shell.

Clean out all the old grease from the hub and fit the new bearing cups, again taking care that they are absolutely square in the hub. Repack with new grease of the recommended grade.

Remove the remaining worn cone from the spindle and replace it with a new one; place new steel balls in the cups, ten each side and holding them with a little grease insert the spindle and screw on the other new cone. (Do not mix used and new ball bearings.) Now adjust the positions of the cones on the spindle to leave the correct length of spindle protruding at each side, i.e., $1\frac{1}{8}$ " approximately from the cone to the end of the spindle on the side opposite the brake drum. Replace the bearing dust cap at each side, place the keyed washers in position and fit the cone locknuts. Tighten the locknut on the brake side, adjust the bearing with the other cone and

tighten the locknut. Replace the brake plate and speedometer drive and refit the wheel to the machine.

REPLACING FRONT WHEEL BRAKE SHOES (RM4)

With the wheel removed from the machine, unscrew the nut at the brake side and take off the keyed washer. The brake plate can now be pulled off the hub spindle. To remove the brake shoes, unscrew the nut on the fixed pivot, take off the cam lever and pull the brake shoe assembly away from the back plate. (See Fig. 56.) Push out the fixed pivot in order to release the brake shoes. Note that there is one return spring and that hardened steel thrust plates are fitted to the ends of the shoes. (See Fig. 57.)

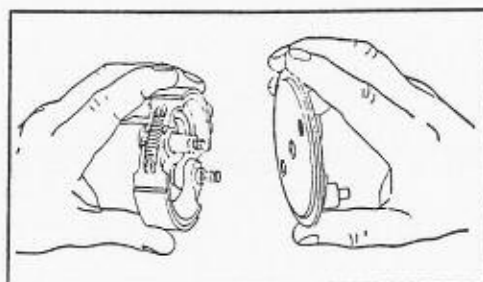

Fig. 56

Removing and refitting front brake shoes

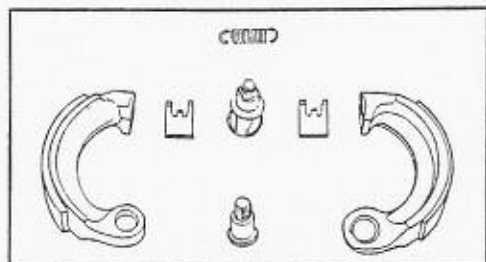

Fig. 57

Exploded view of front brake shoe assembly

The brake linings are bonded to the shoes. The most convenient and satisfactory method of relining

is, of course, exchange shoes available from our Spare Parts Department.

To fit the new shoes, assemble the shoes together with the spring and end plates, place them in position on the cam, squeeze the shoes together until the pivot holes are in line and insert the pivot pin. Bear in mind that the cam and pivot will require a slight smear of grease before assembly. Place the shoes in position on the brake back plate, replace the cam lever in the correct position and refit and tighten the pivot and cam lever nuts. Assemble the brake plate to the wheel and refit the wheel.

FRONT BRAKE (RM6)

The front brake is a heavyweight pattern calliper, operating on the wheel rim.

Points to note regarding the operation and servicing of the front brake are:

1. Worn brake blocks or frayed cables must be replaced.
2. Fit brake shoes the correct way round—with the closed end to the front.
3. Make sure that brake blocks meet the rim squarely.
4. Sufficient lubrication of moving parts and correct adjustment are very important.

REAR WHEEL

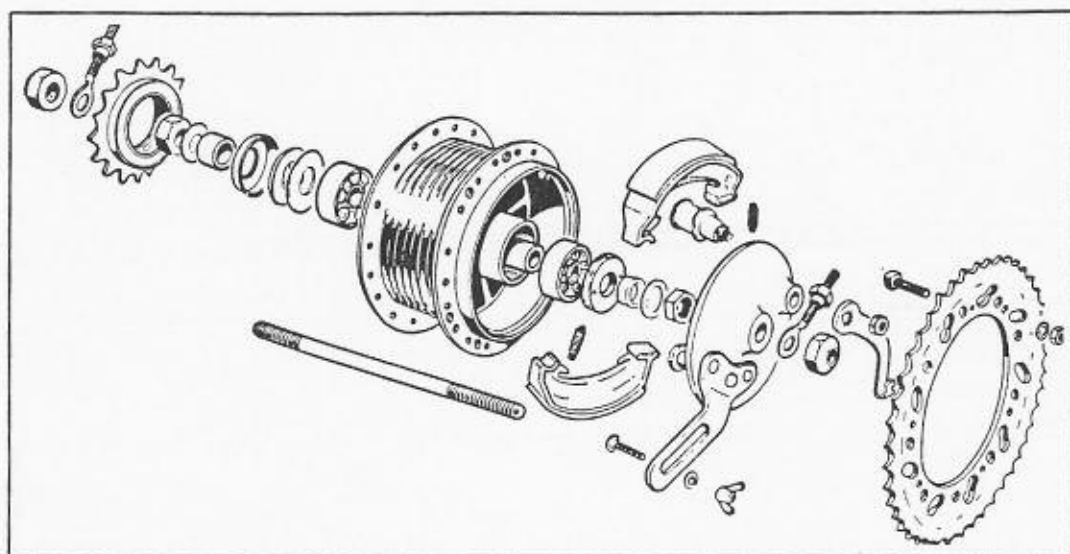

Fig. 58. Exploded view of rear wheel hub

REMOVING AND REFITTING REAR WHEEL

Slacken off the pedal chain jockey wheel and on the RM4 remove the brake arm wing nut and bolt. (See Fig. 59.) Unscrew the wheel spindle nuts far enough to enable the chain adjusters to be pulled out of the slots

in the frame lugs and push the wheel forwards. Lift both chains from their sprockets and disconnect the rear brake cable. The wheel can now be withdrawn from the frame.

Note. It is not necessary to take out the spring links and split the chains when removing the rear wheel.

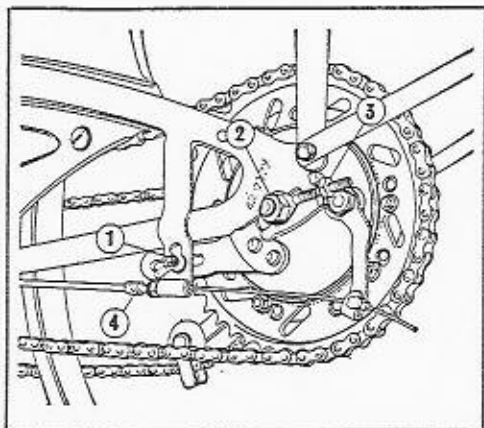

Fig. 59

- 1. Brake arm wingnut 3. Chain adjuster
- 2. Wheel spindle nut 4. Rear brake adjuster

Refit the wheel in the reverse sequence to dismantling, ensuring that the chains are placed on the sprockets before entering the spindle into the frame lugs. Chain adjustment is dealt with on page 32.

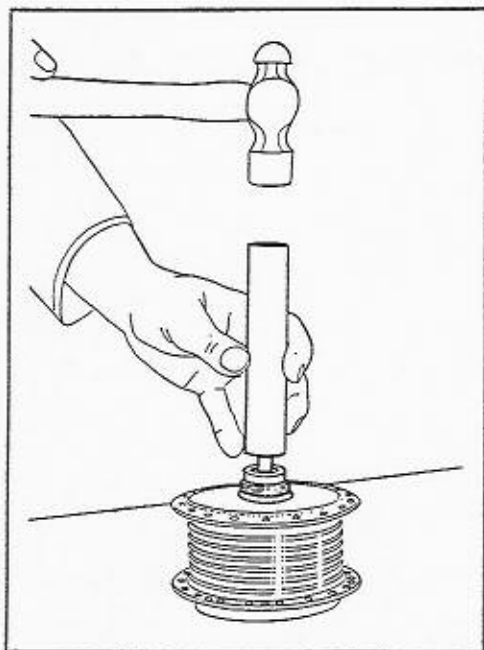

Fig. 60

Fitting rear wheel bearings

REPLACING REAR WHEEL BEARINGS (RM4)

When the wheel has been removed from the frame, the brake plate may be withdrawn from the hub. Unscrew the spindle nut inside the brake drum and pull out the spindle from the freewheel side. Take note of any washers or shims which may be fitted behind the nut in the brake drum. Non-adjustable ball journal bearings are fitted to the rear wheel. The bearing on the brake side is retained by a screwed plug, the removal of which will enable the bearing to be tapped out from the freewheel side, using a soft metal drift. The tubular distance piece between the bearings should be dislodged to give access to the inner side of the bearing. Take care to tap out the bearing squarely in order to avoid damaging the threads for the retaining plug. The bearing on the freewheel side may now be removed, together with the felt seal, shim washer and cap.

When replacing the bearings, fit the one on the brake side first, using a tube of suitable diameter and screw in the retaining plug. Place the wheel spindle in position temporarily, slide the tubular distance piece over the spindle and into the hub and fit the other bearing. (See Fig. 60.) The felt seal with its attendant washers may now be replaced, the flat washer next to the bearing. Now refit the spindle, with the 11 mm. distance piece to the freewheel side and the 6 mm. distance piece in the brake drum, together with any shim washers. Tighten the nuts on the spindle, replace the brake plate, and refit the wheel to the frame.

REAR WHEEL BEARINGS (RM6)

The bearings of the Runabout rear hub are of adjustable cup and cone

type. The procedure for adjustment and replacement of these bearings is basically the same as for the RM4 front hub. Note that the ball bearings are $\frac{1}{2}$ " diameter, 11 at each side, compared with $\frac{1}{4}$ " ball bearings, 10 at each side on the Automatic Moped.

REPLACING REAR WHEEL BRAKE SHOES (RM4)

Remove the brake shoes by prising one of them away from the back plate until it disengages from the cam and pivot. Pull off the shoes and springs. To refit the shoes, assemble the pair, together with the springs. Place one shoe in position on the cam and pivot and press down the other shoe until it clicks into place. (See Fig. 61.)

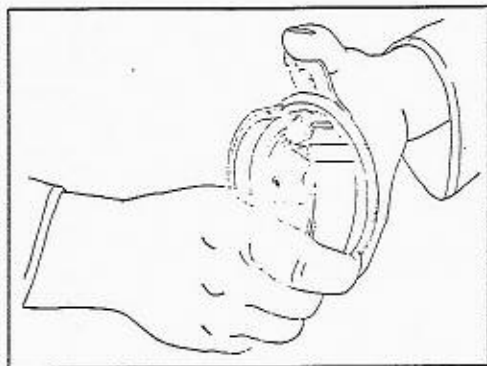

Fig. 61
Removing and refitting rear brake shoes

REPLACING REAR WHEEL BRAKE SHOES (RM6)

After the brake cam lever has been removed the brake shoes may be detached, together with the cam, by sliding them off the fixed pivot on the brake plate.

FRONT FORKS (RM4)

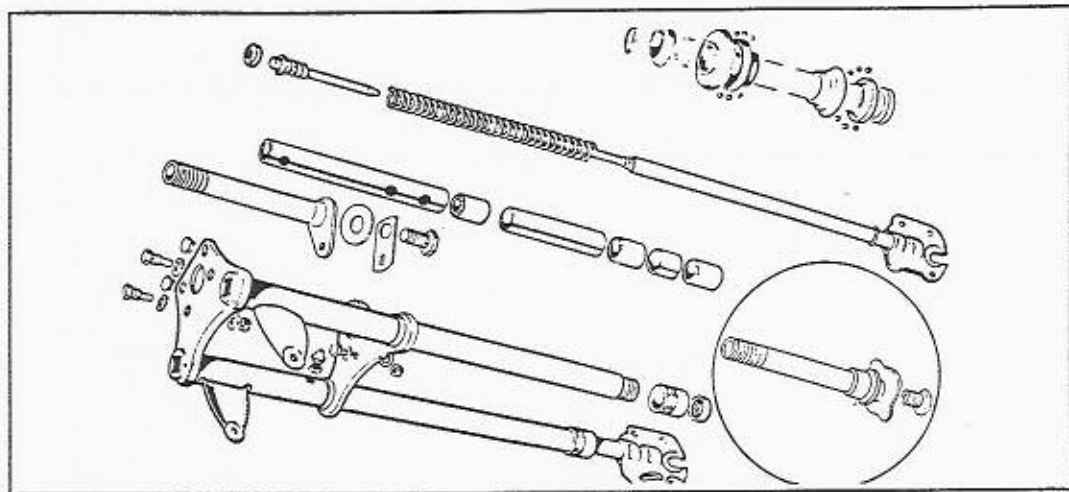

Fig. 62 Exploded view of front forks. Inset: Early pattern steering stem

REMOVING FRONT FORKS

Take out the front wheel as described on page 33. Remove the front mudguard after taking out the three bolts at the bottom of each fork leg. Disconnect the wires and re-

move the headlamp. (On the models fitted with a Lucas headlamp it is not necessary to disconnect the wires, as the headlamp can be passed between the fork legs.) Remove the handlebar as described on pages

41 and 44. Disconnect and remove the horn by loosening the single bolt which secures the bracket to the fork plate. Beneath the steering head will be found a large hexagon-headed bolt secured with a locking plate. Flatten out the tab, remove the large bolt (see Fig. 63) and the

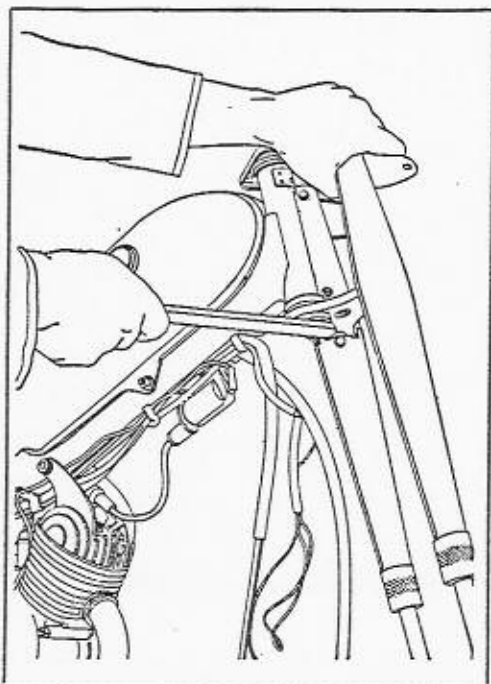

Fig. 63
Removing steering stem bolt

steering head locknut. To remove the forks, gently prise down the bottom plate, at the same time pulling the fork legs forward away from the machine. (See Fig. 64.) When the bottom plate is clear of the steering head, lift the forks off the steering stem.

REMOVING STEERING STEM

If it is required to remove the steering stem, unscrew the knurled adjustable race, taking care not to lose any of the $\frac{5}{32}$ " ball bearings as the stem is removed from the

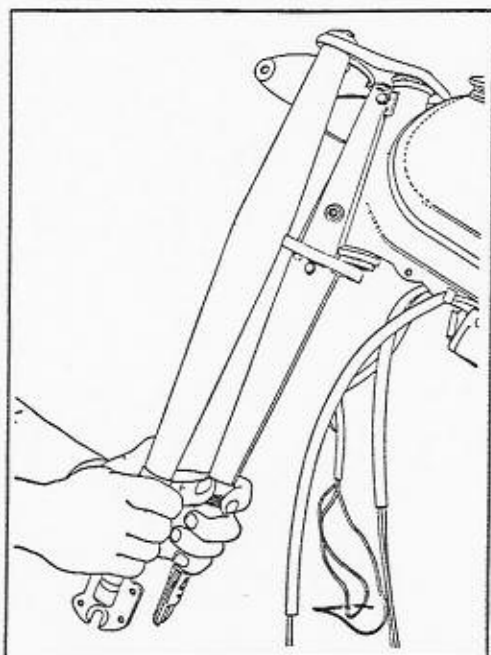

Fig. 64
Removing front forks

frame. There should be 25 ball bearings at each end of the stem.

REFITTING FRONT FORKS

Reassemble the steering stem and bearings into the frame. Place the top plate of the forks over the steering stem and carefully prise the lower plate into position at the bottom of the stem. Note that there are two "ears" which project into the hole in the bottom plate and which must locate in the slots in the bottom of the steering stem. A new locking plate should be fitted to the bolt, followed by the thick clamping washer if fitted, and then the bolt should be screwed into the steering stem. If the locking plate bolt also secures the horn, mount the horn before finally tightening the lower stem bolt. Bend the end of the locking plate over to secure the bolt. Refit the steering head locknut, handlebar, headlamp, mudguard and front wheel.

DISMANTLING FRONT FORKS

Special Tool Available

6200649 Fork bush removal tool.

Depending on the job in hand, it may or may not be necessary to remove the forks from the machine. Assuming that the forks are to remain on the machine, proceed as follows. Take out the front wheel and remove the mudguard as previously described, unscrew the knurled caps at the bottom of the fork legs and take off the knurled nut at the top of each leg. Pull out each fork leg, together with its spring and upper retaining rod. (See Fig. 65.) The spring may be unscrewed from the fork leg and upper retaining rod if necessary.

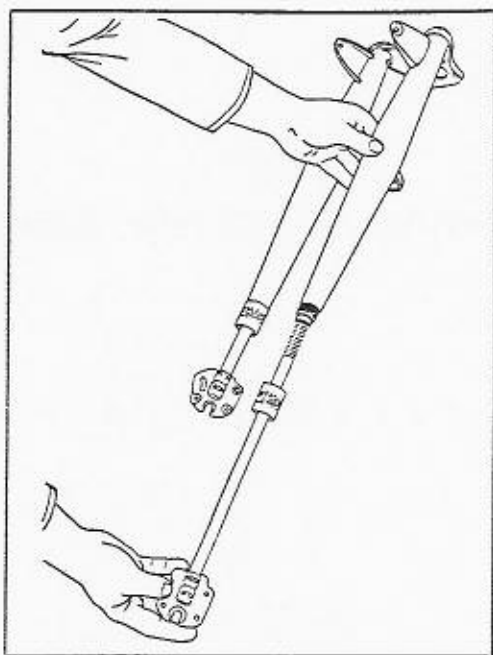

Fig. 65
Removing telescopic leg

There are three guide bushes made of graphite impregnated nylon inside each fork tube, located by spacing tubes of appropriate lengths. (See Fig. 66.) The bushes are a

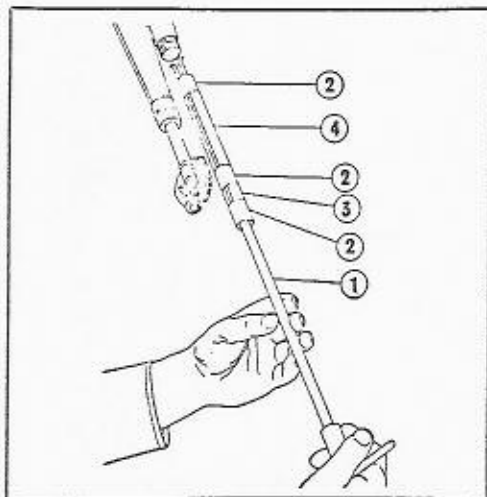

Fig. 66

- | | |
|---------------------------|------------------------|
| 1. Fork bush removal tool | 3. Lower spacing tube |
| 2. Fork bushes | 4. Centre spacing tube |

very light push fit in the fork tubes and no difficulty will be experienced in removing them. Use of the special tool noted above will enable all the bushes in one fork leg to be removed in one operation, together with the two lower spacing tubes. The upper spacer need not be removed for normal servicing.

To remove the fork tube covers, take out the top bolt and the grease nipple on each leg, loosen the lower bolts, detach the inner covers and slide the long outer covers down the fork legs.

A grease seal is incorporated in the cap at the bottom of each fork leg. This may be prised out and replaced, if necessary.

REASSEMBLING FRONT FORKS

Replace the fork tube covers. (Note that they are right and left handed.) Insert in each fork tube, in the following order, the longest spacing tube (if it has been removed), a fork bush, the centre spacing tube, another fork bush, the shortest spacer and the final bush. Place the end

caps on the fork legs, screw on the springs and spring retaining rods. Fit the fork legs into the tubes, screw on the end caps and secure the upper ends of the retaining rods

with the knurled nuts. The right hand fork leg is the one with the curved slot to receive the brake plate peg. Refit the mudguard and front wheel.

FRONT FORKS (RM6)

REMOVING AND REFITTING FRONT FORK

Support the front of the machine and take out the front wheel. Remove the mudguard, which is held in place by four stays and a mounting tube secured by the front brake centre bolt. Release the handlebar stem expander bolt and drop the handlebars to their lowest position. Slacken the twistgrip clamping screws and slide off the grip. Detach both brake cables from the levers, loosen the lever clamp bolts and take off the levers. The enrichment control may be left attached to its cable. Remove the handlebar. Screw off the steering head lock nut, take off the headlamp and bracket (note the spacing washer underneath the lamp bracket), remove the adjustable steering head race and remove the fork. There are 21 $\frac{3}{16}$ " ball bearings at each end of the steering column. Inspect and replace any faulty head races or ball bearings before re-assembling the fork.

ADJUSTING STEERING HEAD BEARINGS

The steering head is correctly adjusted when there is no trace of play in the bearings but the handlebar still turns freely. If the adjustment is too tight the steering will be stiff in operation and the bearings may be damaged. If too loose, there will be a judder when the front brake is applied and the steering may wobble.

To adjust, slacken the steering head locknut and turn the knurled adjusting collar as required, clockwise to decrease the amount of play and anti-clockwise for more play. Tighten the locknut and check the adjustment by applying the front brake and rocking the machine backwards and forwards, with your finger on the gap between the adjusting collar and the top frame cup where it will be possible to feel any play.

HANDLEBAR, CONTROLS AND CABLES (Early Model RM4)

HANDLEBAR ADJUSTMENT

Early production models were fitted with the type of handlebar shown in Fig. 67. To adjust the "rake" of this handlebar, loosen the four U-clamp nuts underneath the top fork plate. Adjust the handlebar to the required position and evenly retighten the nuts.

REMOVING AND REFITTING HANDLEBAR

Pull off the left-hand grip. Remove the grub screws which secure the brake levers and twist grip to the handlebar and disconnect the horn button. Take off the "U" bolts which fasten the handlebar to the fork and slide off the brake levers.

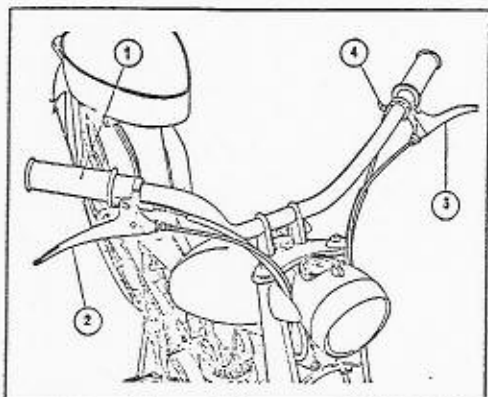

Fig. 67

Handlebars and controls (early model)

1. Twistgrip, operating throttle and decompressor valve
2. Front brake lever
3. Rear brake lever
4. Enrichment (choke) control

Note the positions of the handlebar mounting spacers.

When refitting, ensure that the twistgrip and brake levers are mounted on the handlebar before fitting the "U" bolts and spacers. Set the handlebar to the desired position before finally tightening the "U" bolt nuts, which should be tightened as evenly as possible.

TWISTGRIP

The twistgrip is illustrated in Fig. 68. It is secured to the handlebar by three grub screws. The largest of these screws has a reduced diameter which locates in a hole in the handlebar and ensures correct alignment. If for any reason the twistgrip is removed and refitted, this screw should be replaced first.

The twistgrip sleeve, which carries the rubber grip is attached to the main body by means of the retaining screw and locknut in front of the body. To detach the sleeve, loosen the locknut, unscrew the retaining screw and twist the grip in the direction normally used for closing

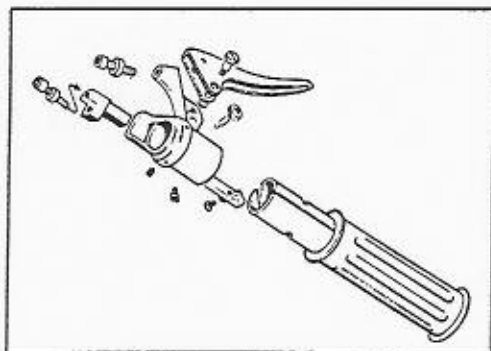

Fig. 68

Exploded view of twistgrip (early model)

the throttle. To replace, reverse this procedure.

The action of the throttle and decompressor cables is controlled by means of two sliding cursors which are drawn along their guides in the twistgrip body as the grip is rotated. A projection on the cursor engages with a spiral groove cut in the twistgrip sleeve and converts the rotary motion of the handgrip into a pull on the cables. Springs in the carburettor and on the decompressor valve provide the return action. Friction damping of the twistgrip is by means of the close fit of the sleeve on the handlebar. If more damping is required, the sleeve should be removed and carefully squeezed in a vice in order to reduce its diameter, the lengthwise slot in the sleeve facilitating this operation.

ADJUSTING CONTROL CABLES

Brake Cables

The adjusters for the front and rear brake cables are screwed into the handlebar lever pivots and are easily adjusted without the need for tools.

The adjustment should be such that the brakes come into operation with the minimum amount of movement of the levers but there must be

no binding of the brake shoes on the drums. After adjustment each wheel should be checked to see that it is able to turn freely.

Decompressor Cable

The decompressor adjuster is screwed into the end of the sliding cursor in the twistgrip (8 mm. spanner for locknut). The control must open the valve sufficiently far (2 mm.) but there must also be slight free play in the cable to ensure that the valve closes completely. The setting of the twistgrip must always be such that the throttle closes to the "neutral" position before the decompressor valve starts to open.

Throttle Cable

Throttle cable setting is by means of the adjuster on the top of the carburettor mixing chamber (8 mm. spanner). There must always be a slight amount of free play in the cable when the twistgrip is in the "neutral" position to prevent the throttle being operated when the handlebar is turned.

Enrichment (Choke) Cable

The cable should be adjusted at the pinch bolt on the handlebar lever to give approximately $\frac{1}{8}$ " free play.

REPLACING CONTROL CABLES

Brake Cables

Disconnect the solderless nipple from the end of the cable remote from the handlebar and pull out the inner cable from the outer at the brake lever end. Detach the outer cable from the machine, if necessary. To fit a new cable, first place the outer cable in position on the frame, then thread the inner cable through the trunnion in the brake lever, through the brake lever fulcrum and on through the outer cable. Fit the

ferrule and the solderless nipple and adjust the cable.

Decompressor Cable

Detach the decompressor cable at the engine end by depressing the valve with the fingers and guiding the inner cable out of the loop in the valve spring. Loosen the inner cable clamp screw (which is screwed into the twistgrip body), pull out the inner cable and remove the cable from the machine. When refitting, insert the inner cable through the twistgrip sliding cursor and into the body, but do not tighten the clamp screw until the engine end of the cable has been connected and the adjustment checked as previously described.

Throttle Cable

To replace the throttle cable, remove the carburettor mixing chamber cover (see page 8), detach the throttle valve and spring and loosen the inner cable clamp screw, which is screwed into the sliding cursor of the twistgrip. The complete cable may now be detached from the machine. To refit the throttle cable, place the complete cable in position on the machine and reassemble the carburettor end first. At the twistgrip end, insert the inner cable into the sliding cursor, but do not tighten the clamp screw until the cable adjustment is satisfactory.

Enrichment (Choke) Cable

Remove the carburettor mixing chamber cover and detach the enrichment valve and cable through the slot in the cover. Loosen the clamp bolt on the control lever and pull out the inner cable, together with the valve and spring. Note which way the valve and spring are fitted, take them off the cable and

refit them to the new inner cable in the same manner. Thread the inner cable through the outer, reassemble the cable to the mixing chamber cover and refit the cover to the car-

burettor. Re-connect the cable to the control lever. Ensure that there is a little free play ($\frac{1}{16}$ ") in the cable when in the "Off" position and tighten the clamp bolt.

HANDLEBAR, CONTROLS AND CABLES

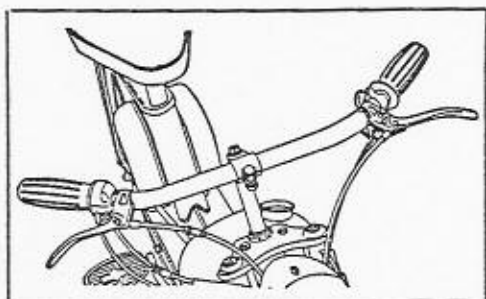

Fig. 69
Handlebar and controls (later model)

HANDLEBAR ADJUSTMENT AND REMOVAL

The later pattern handlebar is secured to the steering stem through the medium of an expander cone, in the same manner as a pedal cycle. To adjust the height or to remove the handlebar, loosen off the expander bolt at the top of the handlebar stem by about three full turns and tap the head of the bolt with a mallet or a block of hardwood to free the expander cone. The handlebar should then be free for adjustment or removal. To secure the handlebar it is only necessary to retighten the expander bolt. It is very important that at least $2\frac{1}{2}$ " of handlebar stem should remain within the steering head, to provide adequate security. The "rake" of the handlebar on the RM4 may be adjusted by means of the clamp bolt at the front of the handlebar stem.

TWISTGRIP

The twistgrip is secured to the handlebar by two screws. Remove these screws to give access to the

cable operating drum and cable nipples. In the lower half of the twistgrip body is a spring and an adjusting screw to regulate the friction of the twistgrip. This should be set so that there is just sufficient friction to prevent the throttle from closing when the grip is released.

ADJUSTING CONTROL CABLES

Screw type cable adjusters are fitted to all cables except the one which operates the carburettor enrichment plunger. The throttle cable adjuster is situated on top of the carburettor, the decompressor cable adjuster is fitted in the cable adjacent to the handlebar and the brake cable adjusters are at the ends of the cables. The enrichment control cable is adjusted by repositioning the solderless nipple on the cable at the control lever.

REPLACING CONTROL CABLES

Brake Cables

Both brake cables may be changed, if necessary, simply by disconnecting each end and threading the complete cable through the frame attachments.

Decompressor Cable

Remove the two screws which clamp the twistgrip to the handlebar, lift off the top of the grip body, unhook the decompressor cable nipple from the operating drum, detach the other end of the cable from the engine and remove the

cable from the frame attachments. When refitting, attach the cable at the engine end first, thread the other end into the lower half of the twist-grip body, together with the throttle cable, so that the two nipples lie on the joining face of the body. Push the lower half of the body into position on the twistgrip drum, when the nipples will spring into engagement with the drum. Be sure they are the right way round, i.e., decompressor cable to the rear. Refit the twistgrip top and securing screws.

Throttle Cable

The throttle cable may be removed and replaced in a similar manner to the decompressor cable, except, of course, the lower end, which is attached to the throttle valve.

Enrichment (Choke) Cable

The enrichment cable may be changed in the same manner as that on the early pattern handlebar, as described on page 41.

LIGHTING

Current is supplied from the magneto-generator to the lighting switch terminal, from which point the horn supply wire is also taken. The remaining wire, on the other terminal, supplies current to the rear lamp, the headlamp bulb connection

being through the spring blade. Turning the switch knob will complete the circuit, joining the two terminals of the switch together and operating both head and rear lamps. (See Fig. 70.)

HEADLAMP (RM4)

The terminals of the switch are of the clip type, which do not require the use of tools to disconnect the wires. To gain access to the headlamp bulb, remove the rim and reflector assembly. The bulb is a "bayonet" fitting in its holder.

To remove and dismantle the switch of the RM4, take off the lamp rim and reflector assembly, slightly compress the switch knob spring on the underside of the switch and turn the spring until the end is freed from the slot in the switch shank. Slide the spring and switch rotor off the shank and remove the switch knob. The terminal plate and insulator can now be removed and the wires disconnected. If necessary, the wires should be marked to enable them to be re-connected correctly. When reassembling, ensure that the rotor is fitted the right way up and that the spring is properly located in the slot.

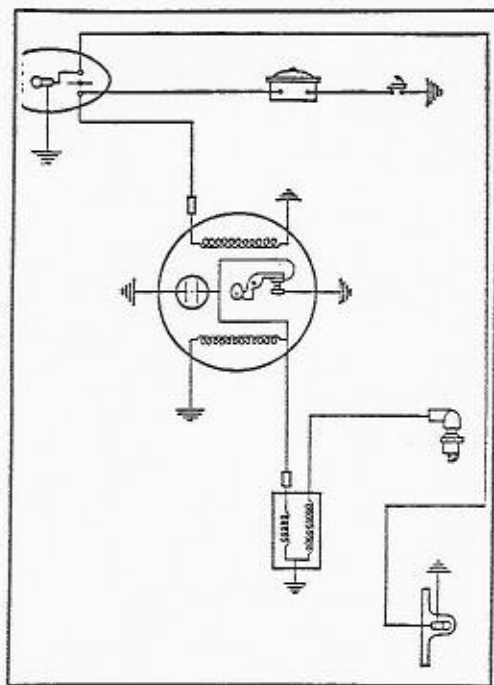

Fig. 70
General wiring diagram

HEADLAMP (RM6)

On the RM6, to remove the lighting switch, file or grind off the switch mounting rivets. Small screws are provided with replacement switches in place of the rivets.

To replace the headlamp bulb, remove the reflector clips and take the reflector out of the rim. The bulb is a "bayonet" fit in the reflector.

HEADLAMP SETTING

The headlamp should be so adjusted that its beam strikes the

road at a distance of approximately 18 ft. in front of the machine. The lamp can be tilted to the required position after loosening the mounting bolts.

REARLAMP

To change the rearlamp bulb, remove the plated screws which retain the rearlamp lens. When refitting, ensure that the rubber seal between the lens and the body is not damaged or misplaced.

FAULT FINDING

In the event of any difficulty being experienced, it should not be hard to remedy if it is tackled systematically with the aid of the following fault finding procedure. **IF THE ENGINE WILL NOT START OR STOPS OF ITS OWN ACCORD** It may be because of:—

(A) Faulty carburation due to:—

- (1) Absence of fuel: refill the tank.
- (2) Fuel tap not turned on: open the tap.
- (3) Carburettor loose causing air leak: tighten.
- (4) Carburettor jet blocked: remove and clean the jet. At the same time clean the float chamber and filter and blow through the internal passages in the carburettor.
- (5) Fuel feed line blocked: clean out fuel pipe, tap and filters, preferably by blowing through with compressed air. Before replacing the pipe on the carburettor connection, turn on the tap to verify that fuel is flowing.
- (6) Fuel filler cap air vent blocked: clear vent.
- (7) Flooded carburettor: turn off the fuel tap, dry the carburettor by opening the throttle wide and kicking the engine over as rapidly as possible. If it does not fire after a few attempts, dry and clean the sparking plug. Before replacing, turn over the engine several times in order to eject the excess fuel from the cylinder. Then turn on the fuel tap again and carry out normal starting procedure. Should flooding still occur, check the float, float needle and seating.
- (8) Engine flooded with fuel due to excessive use of choke control: remedy as in point 7.
- (9) Choke plunger in carburettor not returning: check plunger and operating cable and adjust as necessary. Remedy as in point 7.
- (10) Water in fuel: drain fuel system, clean out carburettor. Refill with correct fuel.

(B) Faulty ignition due to:—

- (11) Dirty or oiled sparking plug: clean the plug.
- (12) Sparking plug electrode gap too wide: reset the gap. If the electrodes are badly burnt or corroded, replace the plug.
- (13) Faulty or broken sparking plug insulator: replace the plug.
- (14) Sparking plug lead disconnected: refit.
- (15) Insulation of H.T. lead to sparking plug faulty and spark shorting to earth: wrap the lead temporarily with insulating tape and replace it as soon as possible.
- (16) Dirty or loose connection in ignition circuit: check all connections and clean or tighten as necessary.
- (17) Dirty, burnt or maladjusted contact breaker points: clean or re-face points and set to correct clearance.

- (18) Condenser or external H.T. ignition coil faulty: have them checked.
- (19) **Note**—The sparking plug could get "wetted" with fuel due to carburettor flooding or to faulty ignition. It could be fouled by descending a long hill without opening the throttle occasionally or by letting the engine run light for too long. A sparking plug running too hot may cause the engine to stop due to "whiskering," which is the formation of a conducting filament between the electrodes. A sparking plug running too cold fouls easily.

(C) Mechanical trouble, as follows:—

- (20) Leakage at a crankcase joint, or at the crankshaft oil seals. Leakage at cylinder head gasket or at decompressor valve.

IF THE ENGINE STARTS, BUT STOPS IMMEDIATELY

- (21) In winter with a cold engine: let the engine warm up with the cold start control in operation.

IF THE ENGINE STOPS WHEN THE THROTTLE IS OPEN

- (22) Engine still cold: allow it to warm up.
- (23) Carburettor jet blocked: clean it.
- (24) Fuel having difficulty in reaching carburettor: clean petrol pipe, tap and filters (see also points 1, 4, 5 and 6).

IF THE ENGINE DOES NOT RUN PROPERLY OR LACKS POWER

- (25) Mixture too weak: see points 1, 3, 4, 5, 6 and 20. Jet too small: fit one size larger jet.
- (26) Mixture too rich (air cleaner blocked with dirt, float not maintaining correct fuel level, jet loose): wash the air cleaner in petrol or adjust or repair the carburettor as necessary. Jet too large: fit one size smaller jet.
- (27) Too much oil in petrol mixture: correct the mixture.
- (28) Sparking plug dirty or of unsuitable type, or with electrodes corroded or with incorrect gap: clean plug and set gap, or if necessary replace plug.
- (29) Contact breaker, condenser or ignition coil not functioning properly: have them checked.
- (30) Exhaust port or exhaust system choked with carbon: decarbonise and thoroughly clean.
- (31) Sparking plug loose in head: tighten securely.
- (32) Mechanical trouble: see points 3 and 20.
- (33) Piston rings gummed-in or excessively worn: clean grooves. Clean rings or replace if necessary.

IF THE ENGINE FOUR-STROKES EXCESSIVELY

- (34) Mixture too rich: remedy as indicated in point 26.
- (35) Exhaust system choked: remedy as indicated in point 30.

Note—If the four-stroking is caused by too rich a mixture, this can easily be verified by turning off the fuel tap whilst riding the machine. Just before the engine stops due to lack of fuel, it will begin to fire correctly. If this does not prove to be the cause, then it is probably due to carbon deposits obstructing the exhaust system.

MISFIRING

- (36) Fault with ignition equipment: check all items.
- (37) Fuel feed deficiency producing a weak mixture (usually accompanied by spitting back in the carburettor: see points 1, 3, 4, 5 and 6).

IF THE ENGINE STOPS OF ITS OWN ACCORD

- (38) Fuel feed deficiency or absence of fuel if the stoppage is preceded by spitting back in the carburettor and back-firing in the exhaust.
- (39) Ignition defect if the stoppage is preceded by a bout of misfiring.

IF THE ENGINE RACES BUT THE MACHINE DOES NOT INCREASE SPEED

- (40) Driving belt slipping: check condition of belt and adjust or renew as required. (The belt can be contaminated by grease or oil due to excessive lubrication of the transmission.)

FAILURE OF LIGHTS (Engine running)

- (A) This can be the result of blown bulb(s). Check by substitution of both headlamp and rearlamp bulb together. Otherwise if the headlamp bulb is defective the rearlamp bulb will blow due to overloading.
- (B) If, after checking as described in (A) the bulbs still do not light with the engine running, proceed to check the generating coil as follows:—
 - (1) Connect a test lamp, consisting of a spare headlamp and rearlamp bulb connected in parallel to give an 18 watt load across the main lead from the generator and a convenient point on the engine. With the engine running at a fast tick-over, the bulbs should light to near full brilliancy.
 - (2) If, after carrying out the test described in (1) the test bulbs light, proceed to check each stage of the circuit from the generator to the lighting switch, referring to the wiring diagram for open-circuits (breakages, etc.). Should any of these faults exist, the bulb will not light. Also check for bad connections, etc., if the bulbs are dim.

M O P E D W O R K S H O P M A N U A L

LIGHT FLICKER (Engine running)

Examine the wiring for loose or dirty connections, or short circuits caused by faulty cable insulation. Check the bulb contacts. Rectify as necessary.

HEADLAMP ILLUMINATION INSUFFICIENT

Check for discoloured bulbs or sagged filaments, replace the bulbs if necessary. Check the reflector; if tarnished or discoloured it should be replaced, as aluminised reflectors should not be cleaned or polished in any way whatsoever.

SPECIAL WORKSHOP TOOLS

Available from our Spare Parts Department

ILLUST. No.	PART No.	DESCRIPTION
1	6200542	Circlip pliers, internal type
2	6200543	Circlip pliers, external type
3	6200544	Cone spanner, 13 × 14 mm. A.F.
4	6200545	Cone spanner, 15 × 16 mm. A.F.
5	6200546	Cone spanner, 17 × 18 mm. A.F.
6	6200547	Steering head locknut spanner, double ended
7	6200548	Clutch drum nut wrench, 14 mm. A.F.
8	6200549	Cylinder head nut wrench, 10 mm. A.F.
9	6200550	Clutch hub nut wrench, 35 mm. A.F.
10	6200551	Steering head lower bolt spanner, 32 mm. A.F.
11	6200552	Steering head locknut spanner, 32 mm. A.F.
12	6200553	Jet socket spanner, 9 mm. A.F.
13	6200554	Jet socket spanner, 8 mm. A.F.
14	6200555	Grease nipple socket spanner, 6 mm. A.F.
15	6200556	Ignition advance gauge
16	6200557	Magneto cam extractor
17	6200558	Clutch drum extractor
18	6200559	Gudgeon pin extractor
19	6200560	Piston ring clamp
20	6200561	Clutch key positioning tool
21	6200562	Thread protector, 10 mm. × 1.0 mm. R.H.
22	6200563	Thread protector, 10 mm. × 1.0 mm. L.H.
23	6200565	Flywheel nut wrench, 10 mm. square
24	6200566	Crankshaft bearing extractor
25	6200567	Flywheel holding tool, steel band type
26	6200569	Flywheel holding tool, webbing strap type
27	6200570	Engine mounting rubber bush fitting tool
28	6200571	Piston stop
29	6200647	Clutch holding tool
30	6200346	Coil centralising ring
31	6200649	Fork brush removal tool
32	6200651	Magnetic extractor for clutch washers
33	6200652	Crankshaft/crankcase gauge
34	6200653	Dummy bearings, 42 × 15 × 13 mm.
35	6200654	Dummy bearings, 42 × 16 × 13 mm.
N.I.	6200655	Rear hub bearing extractor
N.I.	6200650	Replacement springs and rivets for 6200649 fork tool

A.F. = Across flats. N.I. = Not illustrated.

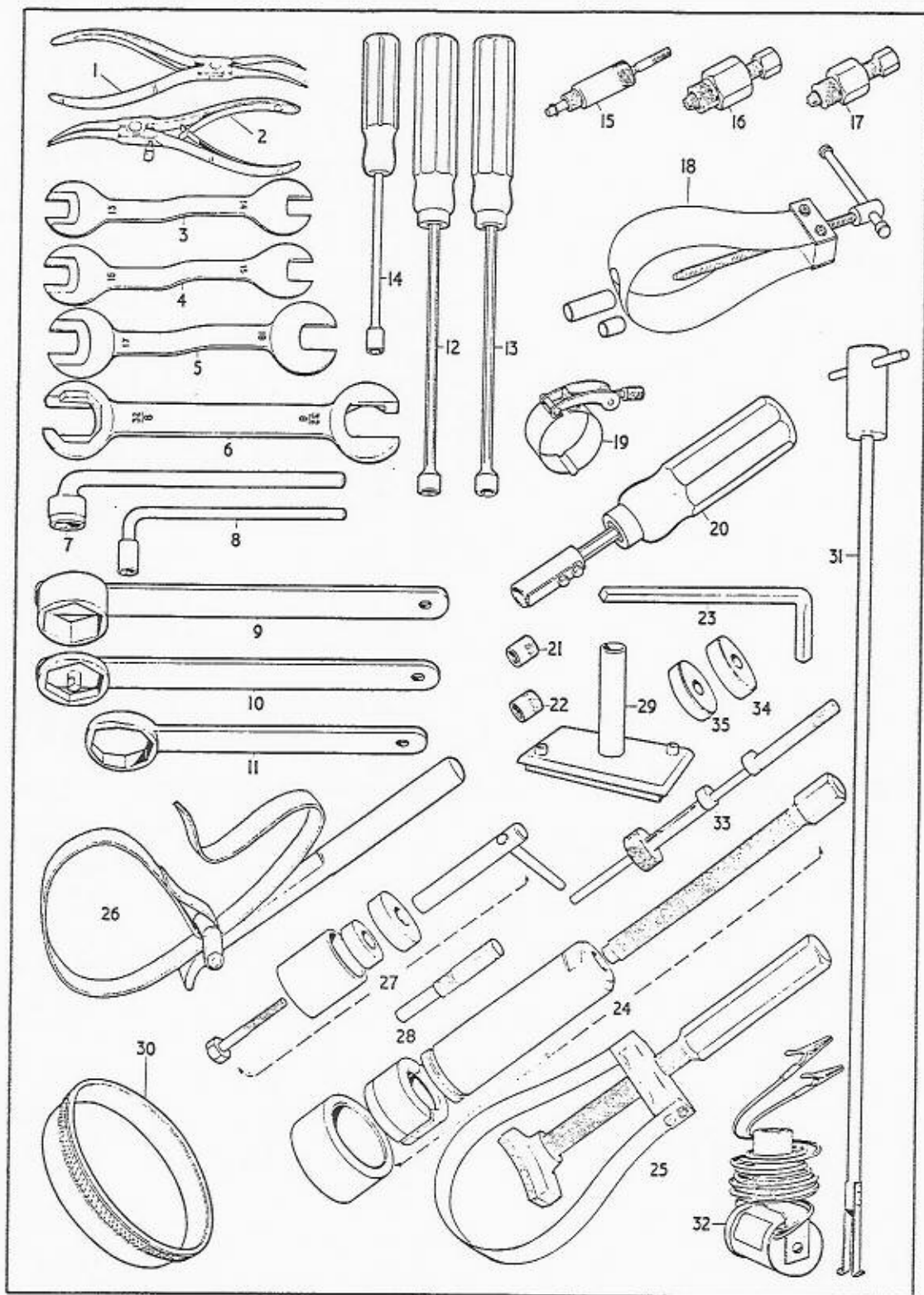

Fig. 72
Special workshop tools

SHIM WASHERS FOR ADJUSTMENT PURPOSES

These are obtainable from our Spare Parts Department for the adjustment of the various assemblies, as set out below.

(A) For the adjustment of crankshaft end float

Part No.	Description
4000314	Shim washer, crankshaft, 0.1 mm. thick.
4000271	Shim washer, crankshaft, 0.2 mm. thick.
4000315	Shim washer, crankshaft, 0.3 mm. thick.
4000316	Shim washer, crankshaft, 0.5 mm. thick.

(B) For the adjustment of cylinder height

Part No.	Description
6200334	Cylinder shim, 0.2 mm. thick.
6200335	Cylinder shim, 0.4 mm. thick.

(C) For the adjustment of clutch end float

Part No.	Description
4000401	Shim washer, clutch hub, 0.1 mm. thick.
4000402	Shim washer, clutch hub, 0.25 mm. thick.
4000403	Shim washer, clutch hub, 0.4 mm. thick.

(D) For the adjustment of bottom bracket end float

Part No.	Description
4020115	Washer, 27 × 16.5 × 1 mm. thick.
4020178	Washer, 27 × 16.5 × 2.5 mm. thick.
4020179	Washer, 27 × 16.5 × 3.2 mm. thick.
4020180	Washer, 27 × 16.5 × 0.5 mm. thick.
4020181	Washer, 27 × 16.5 × 0.8 mm. thick.
4020136	Washer, 27 × 16.5 × 2 mm. thick.
4020117	Washer, 33 × 16.5 × 0.8 mm. thick.
4020175	Washer, 33 × 16.5 × 2 mm. thick.
4020176	Washer, 33 × 16.5 × 1.5 mm. thick.
4020177	Washer, 33 × 16.5 × 2.3 mm. thick.

IceniCAM Information Service

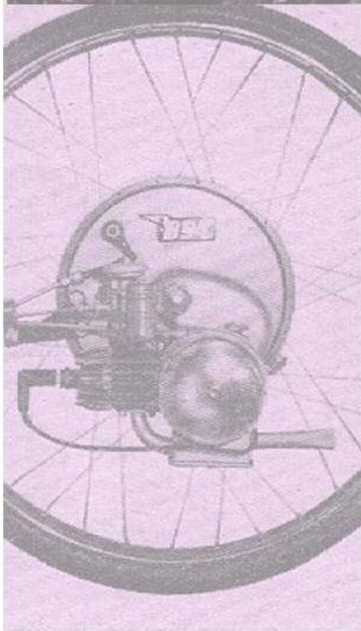
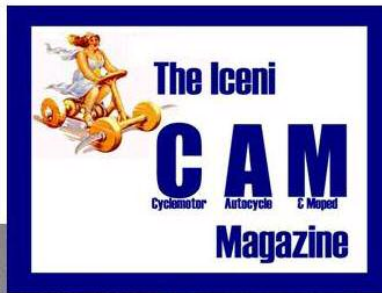

www.icenicam.org.uk