

***RALEIGH***

*Super Tourist*

**MODEL RM11**

**SPARE PARTS LIST**

MTR 348

PRICE 5/-

***RALEIGH***

*Super Tourist*

**MODEL RM11**

**SPARE PARTS LIST**

Issued by  
**RALEIGH INDUSTRIES LIMITED**

**PARTS AND SERVICE DEPARTMENT**  
**LENTON BOULEVARD**  
**NOTTINGHAM**

Telephone: NOTTINGHAM 77761    Telegrams: RALIND NOTTINGHAM  
Telex: NOTTINGHAM 37681

A  COMPANY



## CONTENTS

	Group	Page
Engine and exhaust ... ..	A	2
Automatic clutch and variable pulley ... ..	B	6
Carburettor and Fuel Tap ... ..	C	8
Flywheel magneto ... ..	D	10
Transmission ... ..	E	12
Front fork ... ..	F	14
Frame ... ..	G	16
Front wheel ... ..	H	20
Rear wheel ... ..	I	22
Handlebars and control cables ... ..	Ja	24
Handlebars and control cables (later models) ... ..	Jb	26
Lighting, speedometer and electric horn ... ..	K	28
Toolkit ... ..	L	30
Accessories ... ..	M	30
Service exchange ... ..	N	30
Special workshop tools ... ..	O	32
Numerical index ... ..	—	34

## INSTRUCTIONS FOR ORDERING

It is essential that the following information is provided with every order for spare parts:—

1. Type and Model of the machine.
2. Frame and Engine numbers.
3. Part number, description, colour and quantity of each spare part required.

Failure to provide this necessary information will inevitably lead to delay in fulfilling the order.

Every effort is made to ensure that spare parts are readily available in all areas. Should any part not be immediately available from your local agent, he will be pleased to place an order with Raleigh Service Headquarters for you. It is not normal practice to supply spare parts direct to the public.

NOTE.—We reserve the right to alter or vary the specifications of parts herein listed without prior notice.

The terms issued from time to time by our Motorised Division and the Conditions of Sale in our Guarantee apply.

# ENGINE AND EXHAUST GROUP 'A'

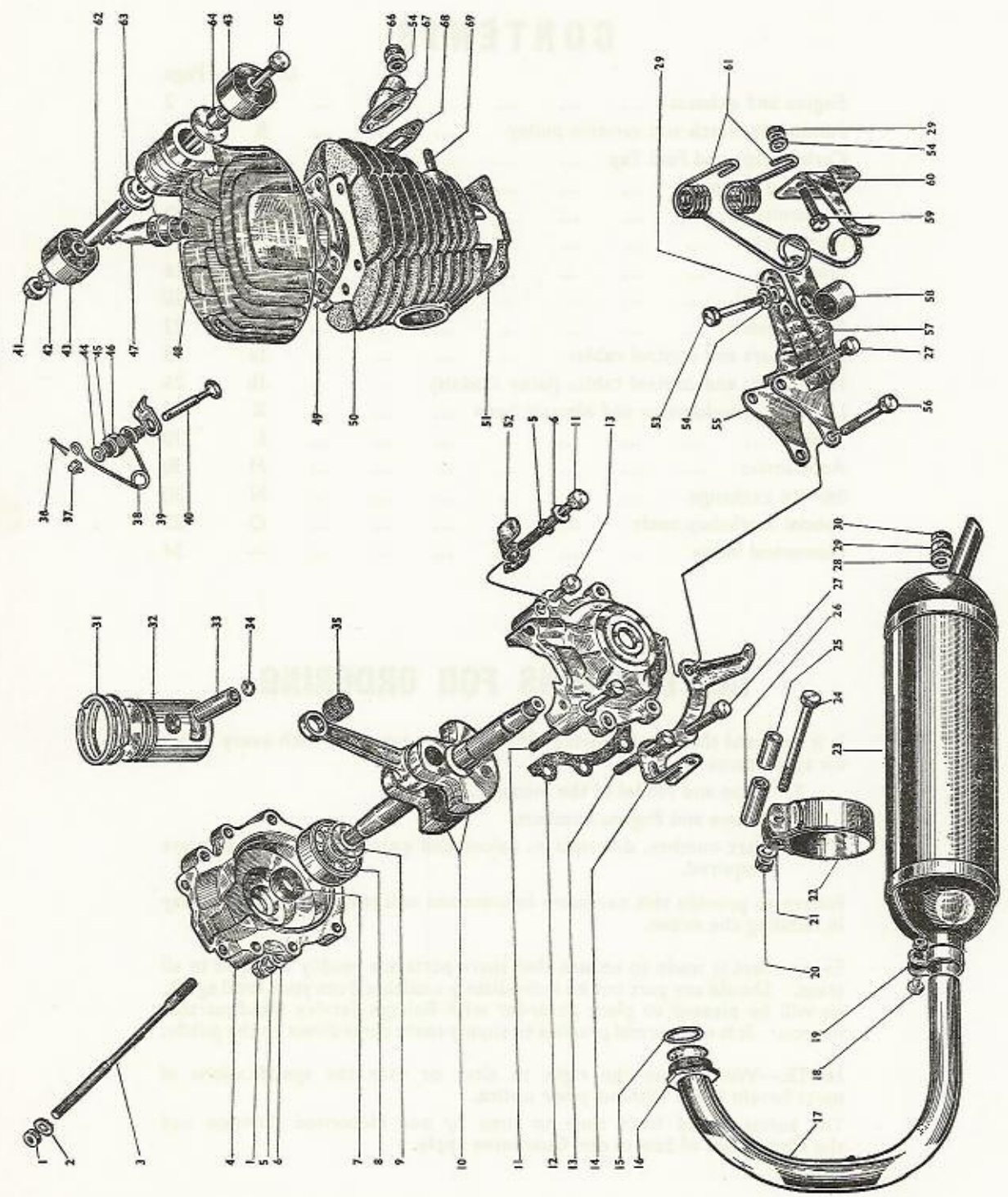



# ENGINE AND EXHAUST GROUP 'A'

ILLUS. NO.	SALES NO.	DESCRIPTION	NUMBER OFF
1	MMN148	Nut, $\phi$ 7 mm., cylinder head and crankcase ... ..	9
2	MMW180	Shakeproof washer, cylinder stud ... ..	4
3	MTA134	Stud, cylinder head ... ..	4
4	MTA135	Crankcase halves (pair) ... ..	1
5	MMW171	Spring washer, $\phi$ 7 mm. ... ..	1
6	MMW173	Plain washer, $\phi$ 7 mm. ... ..	1
7	MTA131	Oil seal, crankcase ... ..	2
8	MTA132	Main bearing, crankshaft ... ..	2
9	MMW169	Shim washer, crankshaft, 0.2 mm. ... ..	V
9	MMW170	Shim washer, crankshaft, 0.3 mm. ... ..	V
9	MMW168	Shim washer, crankshaft, 0.1 mm. ... ..	V
10	MTA310	Crankshaft, c/w small end bearing and gudgeon pin ... ..	1
11	MMB145	Bolt, crankcase, $\phi$ 7 $\times$ 46 $\times$ 1.25 mm. pitch ... ..	2
12	MTA136	Gasket, crankcase ... ..	1
13	MMB146	Bolt, crankcase, $\phi$ 7 $\times$ 34 $\times$ 1 mm. pitch ... ..	2
14	MTA162	Bracket, clutch fairing, lower ... ..	1
15	MTA139	Gasket, exhaust pipe ... ..	1
16	MMN149	Nut, exhaust pipe ... ..	1
17	MTA168	Exhaust pipe ... ..	1
18	MMP130	Bolt, exhaust pipe clip, c/w nut and washer ... ..	1
19	MTA141	Clip, exhaust pipe ... ..	1
20	MMN154	Nut, silencer clip ... ..	2
21	MMW182	Shakeproof washer, silencer bolt ... ..	2
22	MTA171	Silencer clip ... ..	2
23	MTA169	Silencer ... ..	1
24	MMB154	Bolt, silencer clip ... ..	2
25/26	MTA304	Spacer, silencer clip, 13.2 mm. long ... ..	1
25/26	MTA305	Spacer, silencer clip, 18.3 mm. long ... ..	1
25/26	MTA306	Spacer, silencer clip, 25 mm. long ... ..	1
25/26	MTA307	Spacer, silencer clip, 33 mm. long ... ..	1
27	MMB151	Bolt, crankcase, $\phi$ 7 $\times$ 43.5 $\times$ 1 mm. pitch ... ..	1
28	MMW167	Plain washer, silencer end cap ... ..	1
29	MMN152	Nut, $\phi$ 6 mm. ... ..	4
30	MMN153	Locknut, $\phi$ 6 mm. ... ..	1
31	MTA123	Piston ring, $\phi$ 39 mm. ... ..	2
or 31	MTA124	Piston ring, $\phi$ 39.1 mm. ... ..	2
*32	MTA122	Piston, complete (Parts 31 to 34) ... ..	1
33	MTA125	Gudgeon pin ... ..	1
34	MTA126	Circlip, gudgeon pin ... ..	2
35	MTA127	Needle bearing, small end ... ..	1
36	MTA106	Pin, decompressor valve ... ..	1
37	MTA105	Yoke, decompressor valve ... ..	1
38	MTA107	Spring, decompressor valve ... ..	1

# ENGINE AND EXHAUST GROUP 'A'

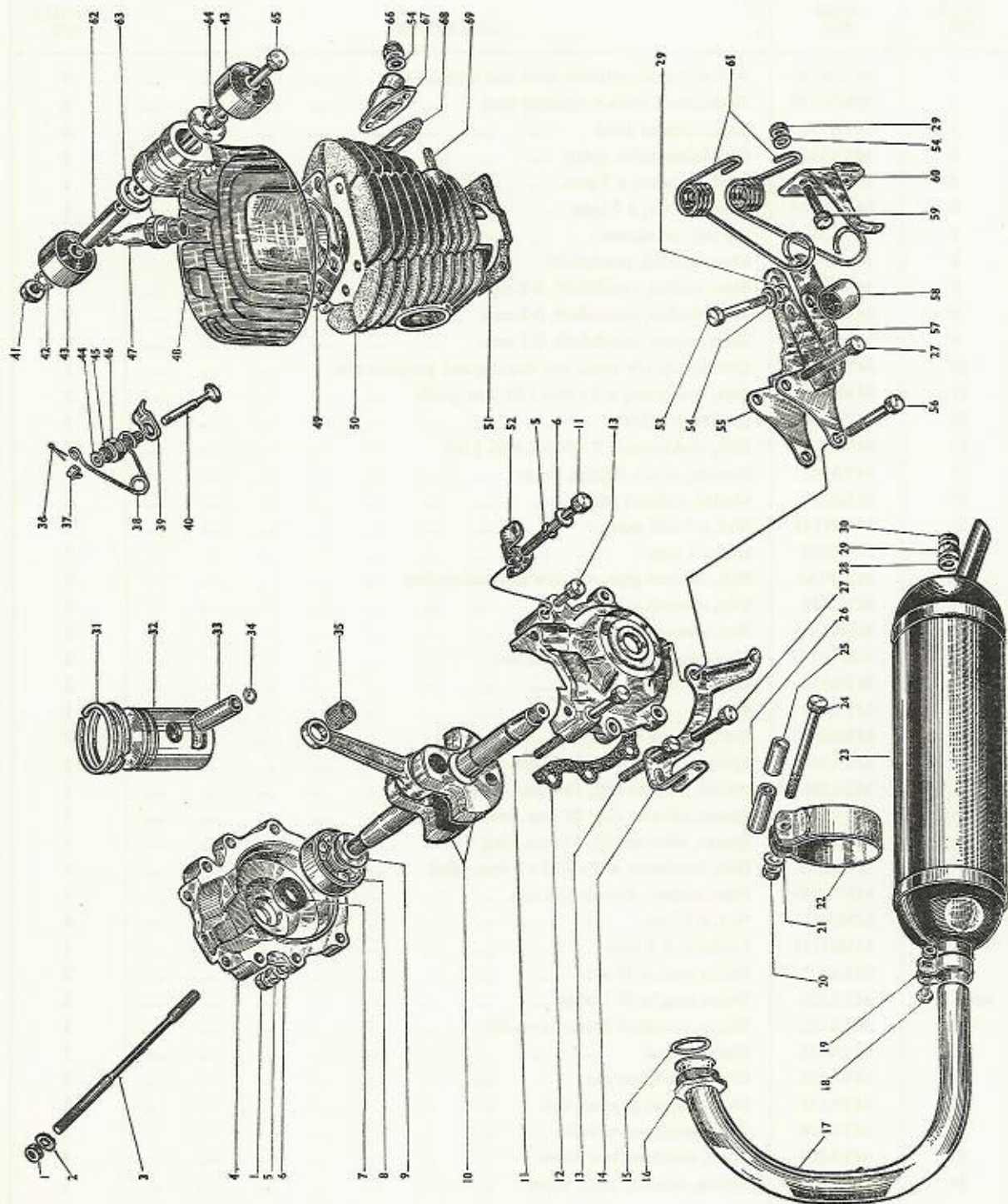



# ENGINE AND EXHAUST

# GROUP 'A'

ILLUS. NO.	SALES NO.	DESCRIPTION	NUMBER OFF
39	MTA110	Anchor plate, decompressor cable ... ..	1
40	MTA112	Decompressor valve, complete (Parts 36 to 40 and 44 to 46) ... ..	1
41	MMN251	Nut, upper engine bolt ... ..	1
42	MMW164	Shakeproof washer, $\phi$ 8 mm. ... ..	1
43	MTA150	Bush, engine mounting ... ..	2
44	MMW165	Retaining washer, decompressor valve seal ... ..	1
45	MTA108	Seal, decompressor valve ... ..	1
46	MTA109	Body, decompressor valve ... ..	1
47	MTA152	Sparking plug ... ..	1
48	MTA154	Cylinder head, c/w decompressor valve ... ..	1
49	MTA116	Gasket, cylinder head ... ..	1
50	MTA155	Cylinder, c/w matched piston ... ..	1
51	MTA121	Gasket, cylinder base ... ..	1
52	MTA161	Bracket, clutch fairing, upper ... ..	1
53	MMB152	Bolt, lower engine mounting ... ..	1
54	MMW181	Shakeproof washer, $\phi$ 6 mm. ... ..	5
55	MTA163	Bracket, lower engine mounting, R.H. ... ..	1
56	MMB147	Bolt, crankcase, $\phi$ 7 $\times$ 48-5 $\times$ 1 mm. pitch ... ..	2
57	MTA283	Bracket, lower engine mounting, L.H. ... ..	1
58	MTA165	Rubber bush, lower engine mounting ... ..	1
59	MMB153	Bolt, lower engine mounting bracket ... ..	2
60	MTA166	Bracket, spring retaining ... ..	1
61	MTA167	Spring, belt tensioning ... ..	1
62	MTA309	Spacer, upper engine mounting, 32 mm. long ... ..	1
63	MTA149	Plug, upper engine mounting ... ..	2
64	MTA308	Spacer, upper engine mounting, 14 mm. long ... ..	1
65	MMB149	Bolt, upper engine mounting ... ..	1
66	MMN147	Self-locking nut, inlet stud ... ..	2
67	MTA157	Inlet adaptor ... ..	1
68	MTA156	Gasket, inlet flange ... ..	1
69	MTA118	Stud, inlet flange ... ..	2
S.A.	MMB155	Set of crankcase bolts ... ..	1
S.A.	MTA174	Set of engine joints and gaskets ... ..	1
N.I.	MTA145	Cylinder shim, 0.2 mm. ... ..	V
N.I.	MTA146	Cylinder shim, 0.4 mm. ... ..	V
<b>New components (later engines with square fins)</b>			
N.I.	MTA316	Cylinder, c/w matched piston ... ..	1
N.I.	MTA317	Cylinder head, c/w decompressor ... ..	1
N.I.	MTA318	Plug, engine mounting ... ..	2
N.I.	MTA319	Nut, exhaust pipe ... ..	1
N.I.	MTA320	Gasket, cylinder head ... ..	1
S.A.—Sub assembly (not illustrated) N.I.—Not illustrated V=Varies $\phi$ =Diameter *—Piston can only be supplied if letter on cylinder top face is quoted or cylinder returned to works for matching			



# AUTOMATIC CLUTCH AND VARIABLE PULLEY

# GROUP 'B'

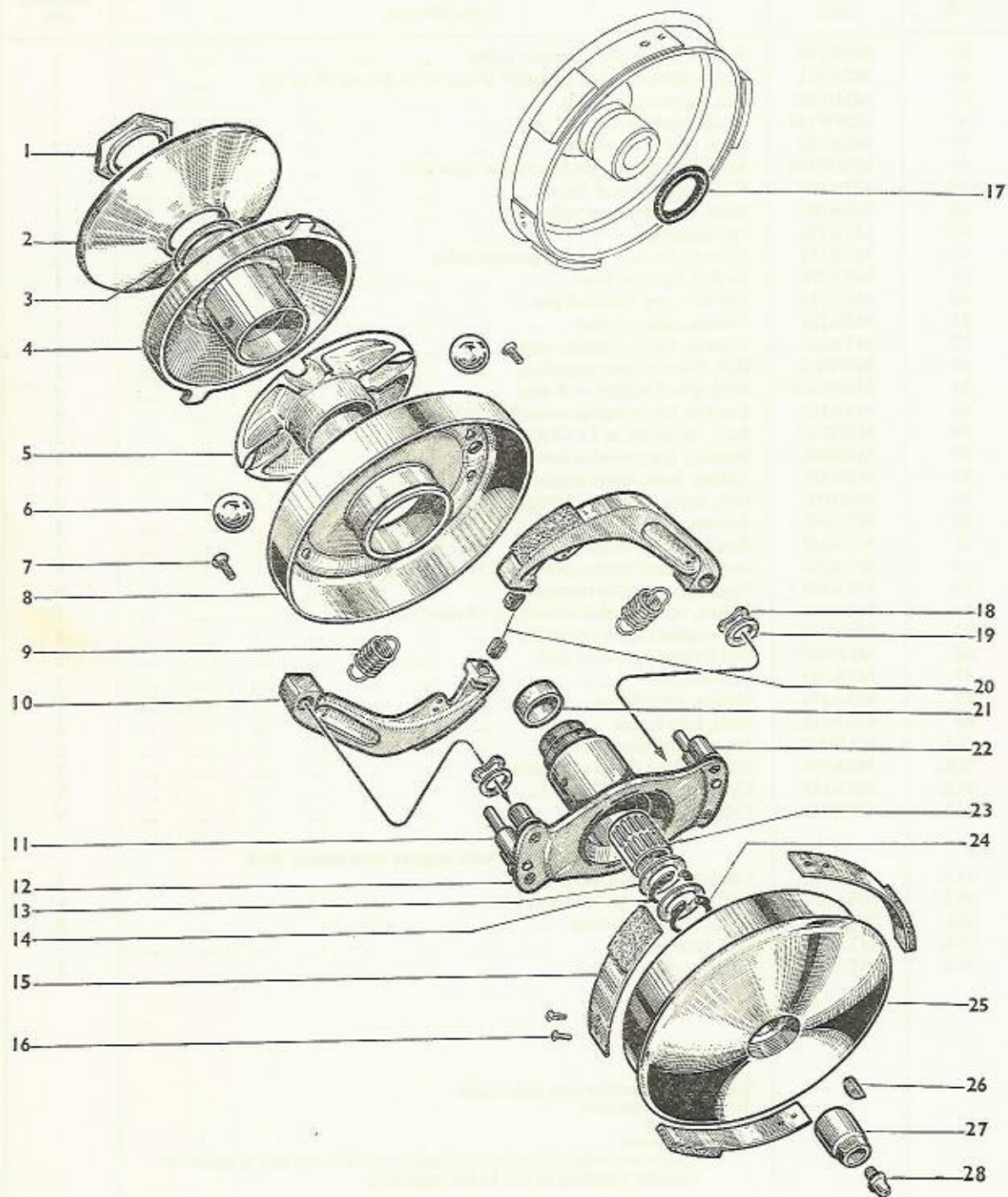

# AUTOMATIC CLUTCH AND VARIABLE PULLEY

# GROUP 'B'

ILLUS. NO.	SALES NO.	DESCRIPTION	NUMBER OFF
1	MMN164	Nut, fixed flange ... ..	1
2	MTB120	Fixed flange, pulley ... ..	1
3	MMW208	Washer, sliding pulley stop ... ..	1
4	MTB121	Sliding flange, pulley ... ..	1
5	MTB122	Plastic cage, speed change balls ... ..	1
6	MML107	Steel ball, $\phi \frac{11}{16}$ " ... ..	4
7	MMB165	Countersunk screw ... ..	4
8	MTB123	Clutch flange ... ..	1
9	MTB128	Spring, clutch shoe ... ..	2
10	MTB110	Clutch shoe, c/w lining ... ..	2
11	MTB127	Driving peg ... ..	2
12	MTB125	Clutch hub ... ..	1
13	MMW202	Locating washer, clutch hub ... ..	2
14	MTB107	Circlip, external, $\phi$ 15 mm. ... ..	1
N.I.	MMW203	Shim washer, clutch, 0-1 mm. ... ..	V
N.I.	MMW204	Shim washer, clutch, 0-25 mm. ... ..	V
N.I.	MMW205	Shim washer, clutch, 0-4 mm. ... ..	V
15	MTB117	Leaf spring, c/w lining and rivets ... ..	3
16	MTB118	Rivet, leaf spring ... ..	6
17	MTB130	Sealing ring, clutch drum ... ..	1
18	MMW207	Curved spring washer, clutch ... ..	2
19	MMW361	Plain washer, $\phi$ 10 mm. ... ..	2
20	MTB112	Rubber stop, clutch shoe ... ..	2
21	MTB124	Hollow plug, needle bearing ... ..	1
22	MTB126	Fulcrum pin ... ..	4
23	MTB106	Needle roller bearing, clutch ... ..	1
24	MTB108	Circlip, internal, $\phi$ 22 mm. ... ..	1
25	MTB156	Clutch drum, c/w lined springs ... ..	1
26	MTB119	Key, clutch drum ... ..	1
27	MMN288	Nut, clutch drum ... ..	1
28	MTB109	Grease nipple, clutch ... ..	1
S.A.	MTB152	Clutch and variable gear unit (Parts 1 to 25) ... ..	1

$\phi$  = Diameter  
 V = Varies  
 N.I. = Not illustrated  
 S.A. = Sub assembly



# CARBURETTOR AND FUEL TAP

# GROUP 'C'

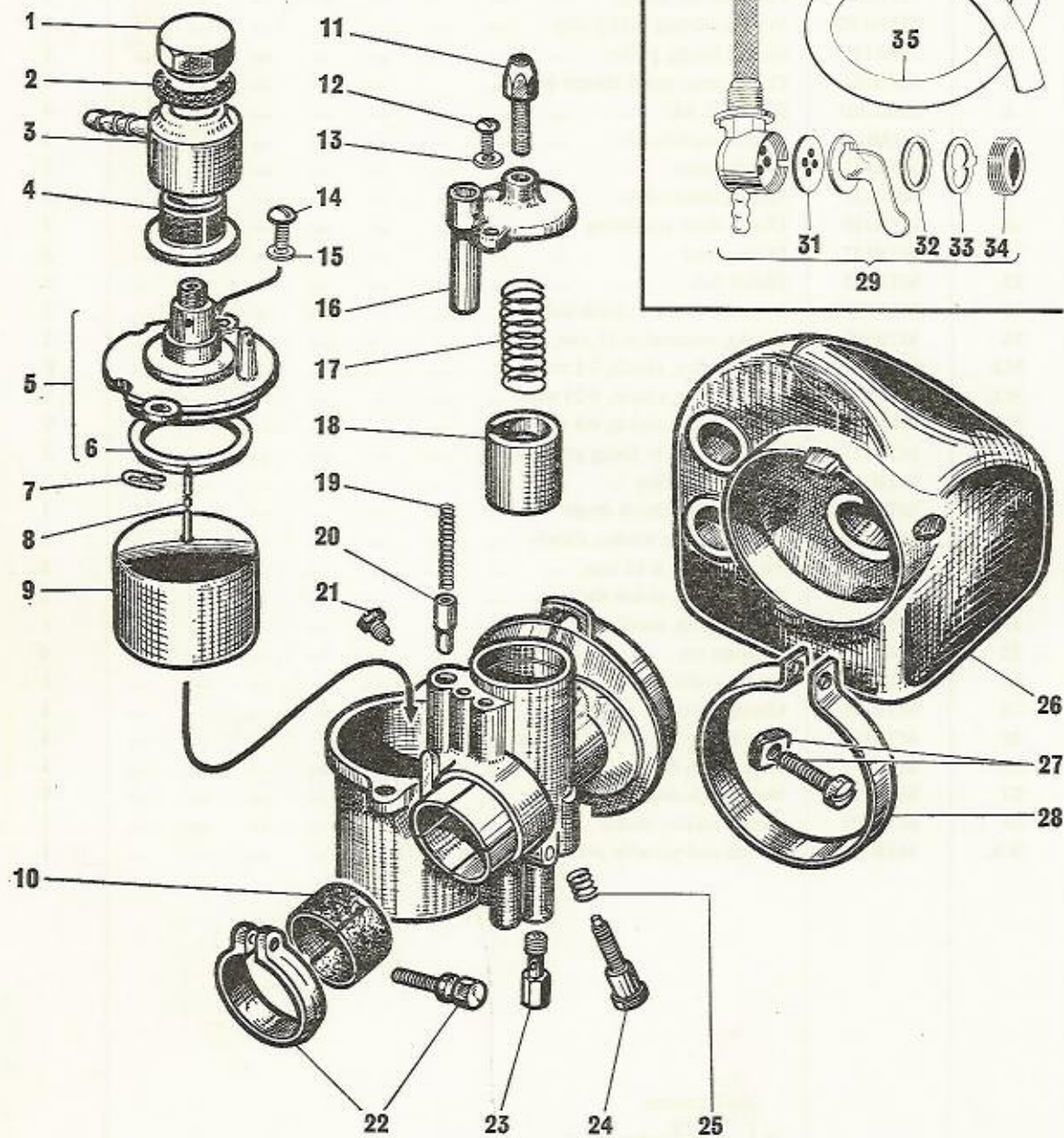

# CARBURETTOR AND FUEL TAP

# GROUP 'C'

ILLUS. NO.	SALES NO.	DESCRIPTION	NUMBER OFF
1	MMN182	Cap nut, banjo union ... ..	1
2	MMW251	Fibre washer, banjo union ... ..	1
3	MTH141	Banjo union ... ..	1
4	MTH142	Filter, banjo union ... ..	1
5	MTH210	Float chamber cover, c/w sealing ring ... ..	1
6	MTH211	Sealing ring, float chamber ... ..	1
7	MTH147	Clip, float needle ... ..	1
8	MTH146	Float needle ... ..	1
9	MTH148	Float ... ..	1
10	MTH150	Fibre sleeve, carburettor stub ... ..	1
11	MTH106	Adjuster, throttle cable ... ..	1
12	MMB179	Screw, mixing chamber cover ... ..	1
13	MMW262	Washer, mixing chamber cover screw ... ..	1
14	MMB177	Screw, float chamber cover ... ..	2
15	MMW263	Washer, float chamber cover screw ... ..	2
16	MTH138	Mixing chamber cover ... ..	1
17	MTH140	Return spring, throttle slide ... ..	1
18	MTH139	Throttle slide ... ..	1
19	MTH110	Return spring, enrichment plunger ... ..	1
20	MTH111	Enrichment plunger ... ..	1
21	MMB180	Guide screw, throttle slide ... ..	1
22	MTH149	Clip, carburettor stub, c/w screw ... ..	1
23	MTH152	Main jet, No. 24 ... ..	1
or 23	MTH153	Main jet, No. 25 ... ..	1
or 23	MTH154	Main jet, No. 26 ... ..	1
24	MMB182	Adjusting screw, throttle slide ... ..	1
25	MTH151	Spring, throttle slide adjusting screw ... ..	1
26	MTH213	Air cleaner, complete (Parts 26 to 28) ... ..	1
27	MMP144	Screw and nut, air cleaner clip ... ..	1
28	MTH137	Clip, air cleaner ... ..	1
S.A.	MTH214	Carburettor, complete (Parts 1 to 28) ... ..	1
29	MTH217	Fuel tap ... ..	1
30	MMW245	Fibre washer, $\frac{1}{16}$ " thick ... ..	V
or 30	MMW246	Fibre washer, $\frac{3}{32}$ " thick ... ..	V
31	MTH195	Cork seal, fuel tap ... ..	1
32	MTH196	Fibre seal, fuel tap ... ..	1
33	MTH197	Spring, fuel tap seal ... ..	1
34	MTL270	Seal retainer, fuel tap ... ..	1
35	MTH216	Fuel pipe ... ..	1

V = Varies  
S.A. = Sub assembly



# FLYWHEEL MAGNETO GROUP 'D'

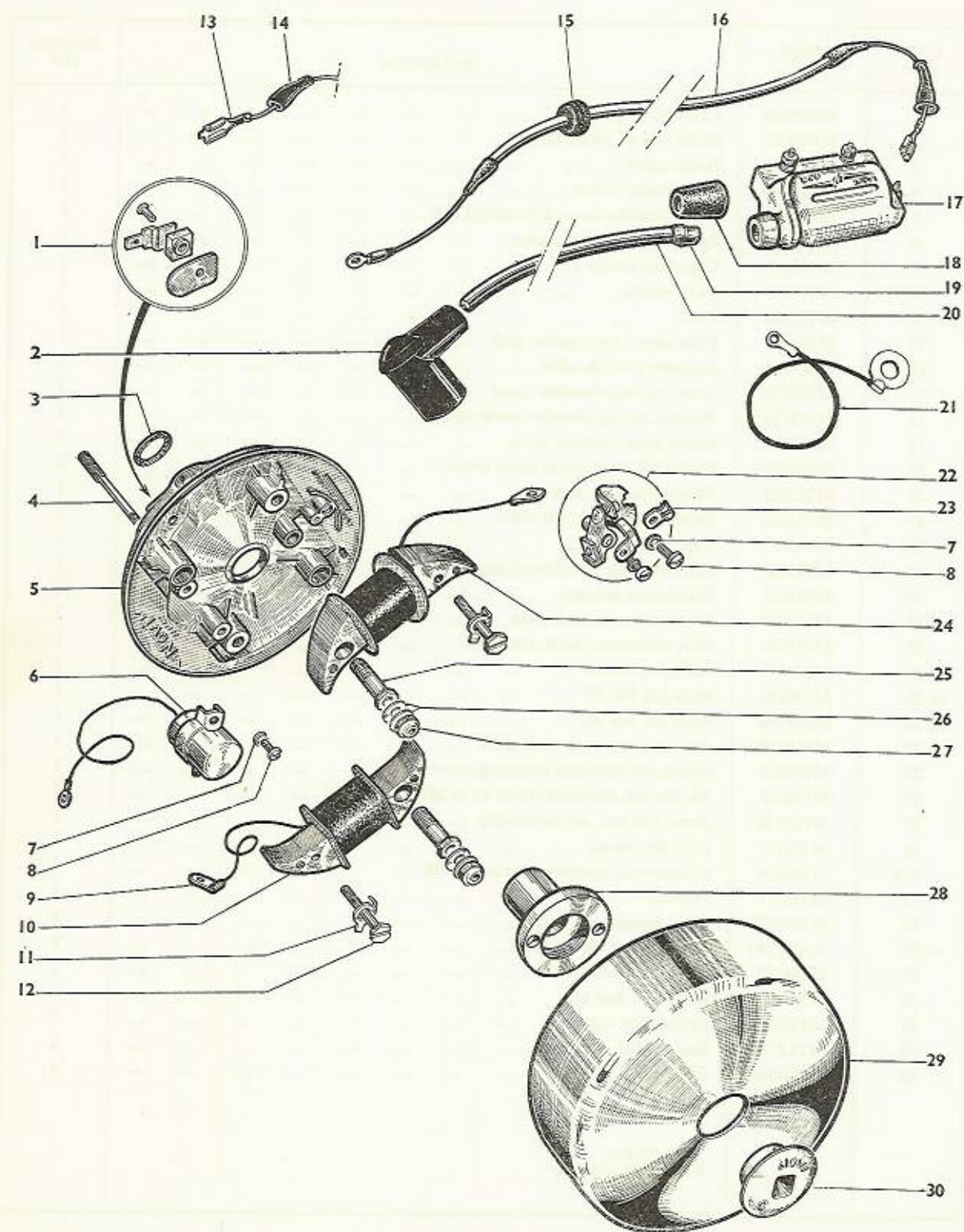

# FLYWHEEL MAGNETO GROUP 'D'

ILLUS. NO.	SALES NO.	DESCRIPTION	NUMBER OFF
1	MTM138	Lighting terminal, complete ... ..	1
2	MTM153	Suppressor cover, sparking plug... ..	1
3	MTM137	Sealing ring, stator plate ... ..	1
4	MTM129	Stud, stator plate securing ... ..	2
5	MTM157	Stator plate, bare ... ..	1
S.A.	MTM167	Stator plate, c/w coils, contact breaker and capacitor ... ..	1
6	MTM134	Capacitor ... ..	1
7	MMW308	Spring washer, $\phi$ 4 mm. ... ..	4
8	MMB238	Screw, $\phi$ 4 $\times$ 10 $\times$ 0.75 mm. pitch ... ..	4
9	MTM132	Terminal tag, internal coils ... ..	2
10	MTM131	Ignition coil, L.T. ... ..	1
11	MTM133	Locking tab, coil screw ... ..	2
12	MMB236	Screw, coil securing ... ..	2
13	MTP161	Spade terminal ... ..	2
14	MTP162	Plastic cover, spade terminal ... ..	2
15	MTM144	Grommet, L.T. wire ... ..	1
16	MTM143	Ignition L.T. lead ... ..	1
17	MTM145	H.T. coil, external... ..	1
18	MTM146	Rubber cap, H.T. lead ... ..	2
19	MTM147	Terminal, H.T. lead ... ..	1
20	MTM148	H.T. lead, c/w terminal ... ..	1
21	MTM154	Earth wire, complete ... ..	1
22	MTM136	Contact breaker, complete ... ..	1
23	MTM135	Adjusting clip, contact breaker ... ..	1
24	MTM166	Lighting coil ... ..	1
25	MMB237	Hollow screw, coil securing ... ..	2
26	MMW307	Belleville washer, $\phi$ 5 mm. ... ..	4
27	MMN226	Self-locking nut, stator plate ... ..	2
28	MTM139	Cam, contact breaker ... ..	1
29	MTM165	Flywheel ... ..	1
30	MMN227	Nut, flywheel ... ..	1
S.A.	MTM164	Flywheel magneto, complete, less external H.T. coil ... ..	1
N.I.	MTM168	Gasket, stator plate ... ..	1

$\phi$  = Diameter  
 S.A. = Sub assembly (not illustrated)  
 N.I. = Not illustrated



# TRANSMISSION GROUP 'E'

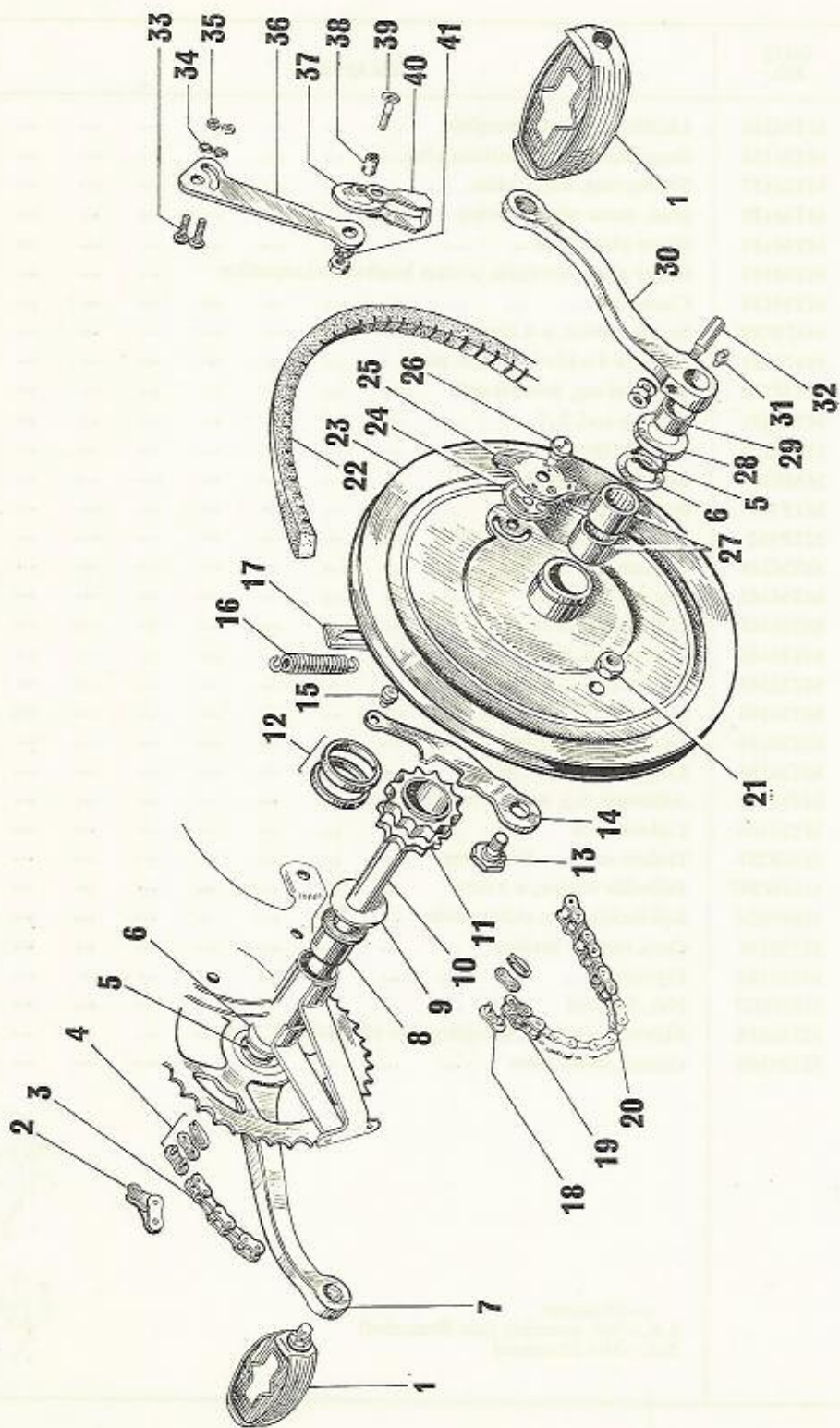

## TRANSMISSION

## GROUP 'E'

ILLUS. NO.	SALES NO.	DESCRIPTION	NUMBER OFF
1	MTD210	Pedals, 4" solid rubber ... ..	1 pr.
2	MTD199	Cranked link, pedal chain ... ..	1
3	MTD197	Pedal chain, 93 pitches ... ..	1
4	MTD198	Connecting link, pedal chain ... ..	1
5	MTD181	Circlip, bottom bracket axle ... ..	2
6	MMW346	Spacing washer, 16.5×26×0.5 mm. ... ..	V
or 6	MMW231	Spacing washer, 16.5×26×1 mm. ... ..	V
or 6	MMW347	Spacing washer, 16.5×26×0.8 mm. ... ..	V
7	MTD249	Chainwheel and R.H. crank ... ..	1
8	MTD211	Bush, bottom bracket ... ..	2
9	MMW232	Spacing washer, 16.5×33×0.8 mm. ... ..	1
10	MTD256	Axle, bottom bracket ... ..	1
11	MTD245	Sprocket, 11t., c/w plastic rings ... ..	1
12	MTD253	Pair of plastic rings, B/B sprocket ... ..	1 pr.
13	MMP135	Fulcrum bolt, c/w nut ... ..	1
14	MTD251	Lock lever assembly, complete (Parts 13 to 17) ... ..	1
15	MTD190	Rivet pin, lock lever ... ..	1
16	MTD188	Spring, lock lever ... ..	1
17	MTD189	Guide plate, lock lever spring ... ..	1
18	MTD195	Connecting link, drive chain ... ..	1
19	MTD196	Cranked link, drive chain ... ..	1
20	MTD258	Drive chain, 95 pitches ... ..	1
21	MMN276	Nut, fulcrum bolt ... ..	1
22	MTD221	Drive belt ... ..	1
23	MTD257	Bottom bracket pulley, complete ... ..	1
24	MTD191	Spring disc, turnbutton ... ..	1
25	MTD220	Turnbutton, lock lever ... ..	1
26	MTD192	Fulcrum rivet, turn button ... ..	1
27	MTD184	Needle roller bearing, bottom bracket pulley ... ..	2
28	MTD185	End cap, pulley hub ... ..	1
29	MTD216	Spacer, L.H. crank ... ..	1
30	MTD248	L.H. crank ... ..	1
31	MTD179	Grease nipple, bottom bracket ... ..	1
32	MTD177	Cotter pin, c/w nut and washer ... ..	2
33	MMB171	Screw, pedal chain tensioner securing ... ..	2
34	MMW233	Spring washer, tensioner screw ... ..	2
35	MMN171	Nut, pedal chain tensioner securing ... ..	2
36	MTD204	Pedal chain tensioner, complete (Parts 33 to 41) ... ..	1
37	MTD201	Wheel, pedal chain tensioner ... ..	1
38	MTD203	Bush, pedal chain tensioner ... ..	1
39	MMP132	Spindle, pedal chain tensioner wheel, c/w nut ... ..	1
40	MTD202	Pedal chain guide ... ..	1
41	MMW157	Shakeproof washer, tensioner spindle ... ..	1

V=Varies



# FRONT FORK GROUP 'F'

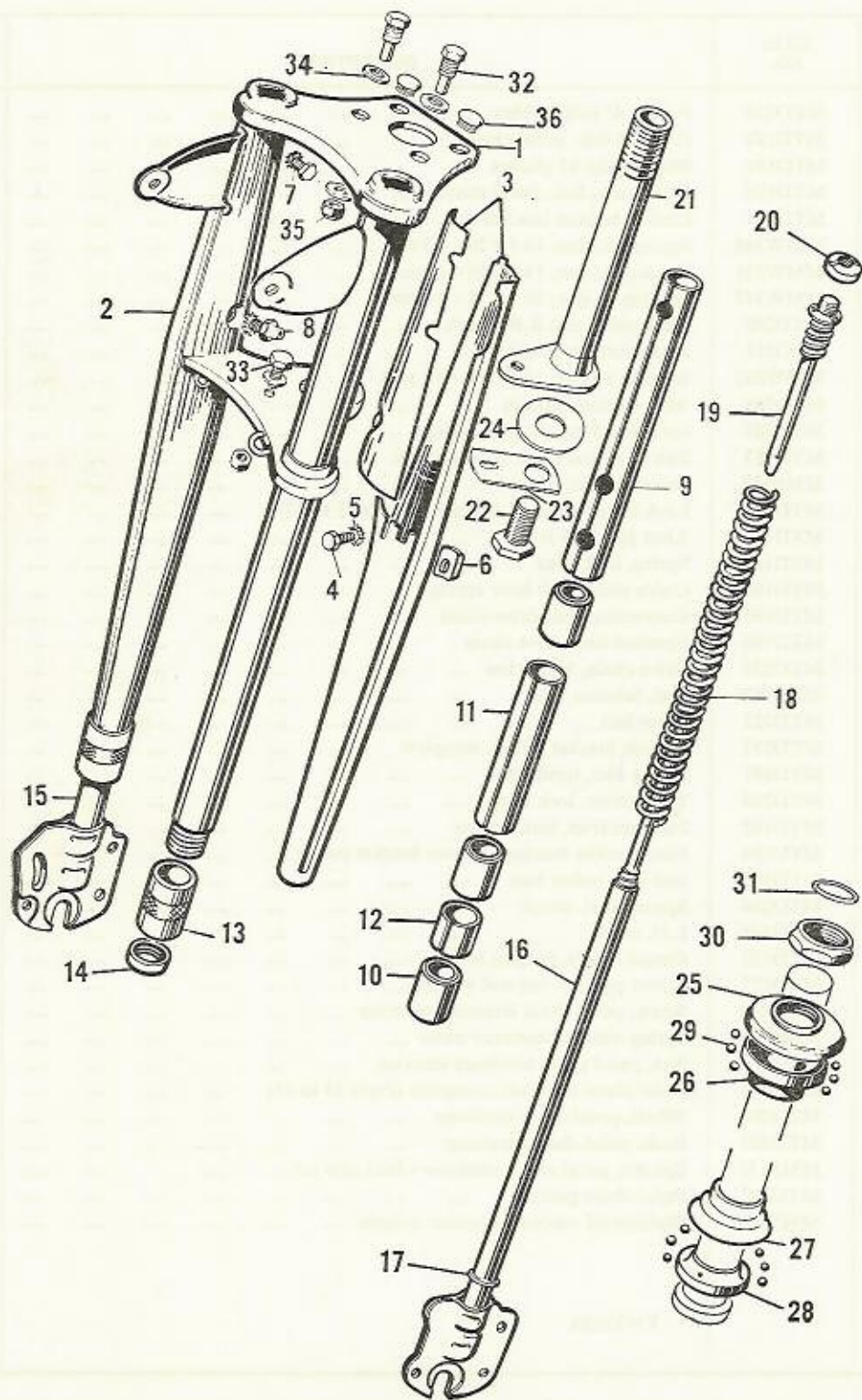

# FRONT FORK GROUP 'F'

ILLUS. NO.	SALES NO.	DESCRIPTION	NUMBER OFF
1	MTJ220	Fork tube, c/w covers ... ..	1
2	MTJ221	Cover, fork tube, R.H. ... ..	1
3	MTJ222	Cover, fork tube, L.H. ... ..	1
4	MMB195	Bolt, fork cover, 9 mm. long ... ..	2
5	MMW157	Shakeproof washer, fork cover ... ..	6
6	MTJ127	Spacer, fork cover... ..	2
7	MMB196	Bolt, fork cover, 5.5 mm. long ... ..	2
8	MTJ128	Grease nipple, front fork ... ..	2
9	MTJ103	Upper spacer, fork tube ... ..	2
10	MTJ104	Bush, fork tube ... ..	6
11	MTJ105	Centre spacer, fork tube ... ..	2
12	MTJ106	Lower spacer, fork tube ... ..	2
13	MTJ196	Fork end cap, c/w seal ... ..	2
14	MTJ108	Grease seal ... ..	2
15 } 16 }	MTJ177	Telescopic legs, front fork ... ..	1 pr.
17	MTJ111	Stop ring, telescopic leg ... ..	2
18	MTJ112	Fork spring ... ..	2
19	MTJ113	Spring retaining rod ... ..	2
20	MMN187	Slotted nut, spring retaining rod ... ..	2
S.A.	MTJ223	Front fork, complete (Parts 1 to 20) ... ..	1
21	MTJ192	Steering stem ... ..	1
22	MMB192	Bolt, steering stem ... ..	1
23	MTJ116	Locking plate, steering stem ... ..	1
24	MMW265	Clamp washer, steering stem ... ..	1
25	MTJ117	Adjustable bearing cone, steering head ... ..	1
26	MTJ118	Upper bearing cup, steering head ... ..	1
27	MTJ119	Lower bearing cup, steering head ... ..	1
28	MTJ120	Lower bearing cone, steering head ... ..	1
29	MML101	Ball bearing, $\varnothing \frac{1}{2}$ " ... ..	50
30	MMN188	Locknut, steering head ... ..	1
S.A.	MTJ121	Set of steering bearings, complete (Parts 25 to 30) ... ..	1 set
31	MTJ122	Sealing ring, locknut ... ..	1
32	MMB193	Bolt, steering stop ... ..	2
33	MMB194	Bolt, locking plate ... ..	1
34	MMW101	Plain washer, $\varnothing \frac{1}{4}$ " ... ..	6
35	MMN189	Self-locking nut, $\varnothing \frac{1}{4}$ " ... ..	3
36	MTJ123	Plastic plug, white... ..	2

$\varnothing$  = Diameter  
S.A. = Sub assembly



# FRAME GROUP 'G'

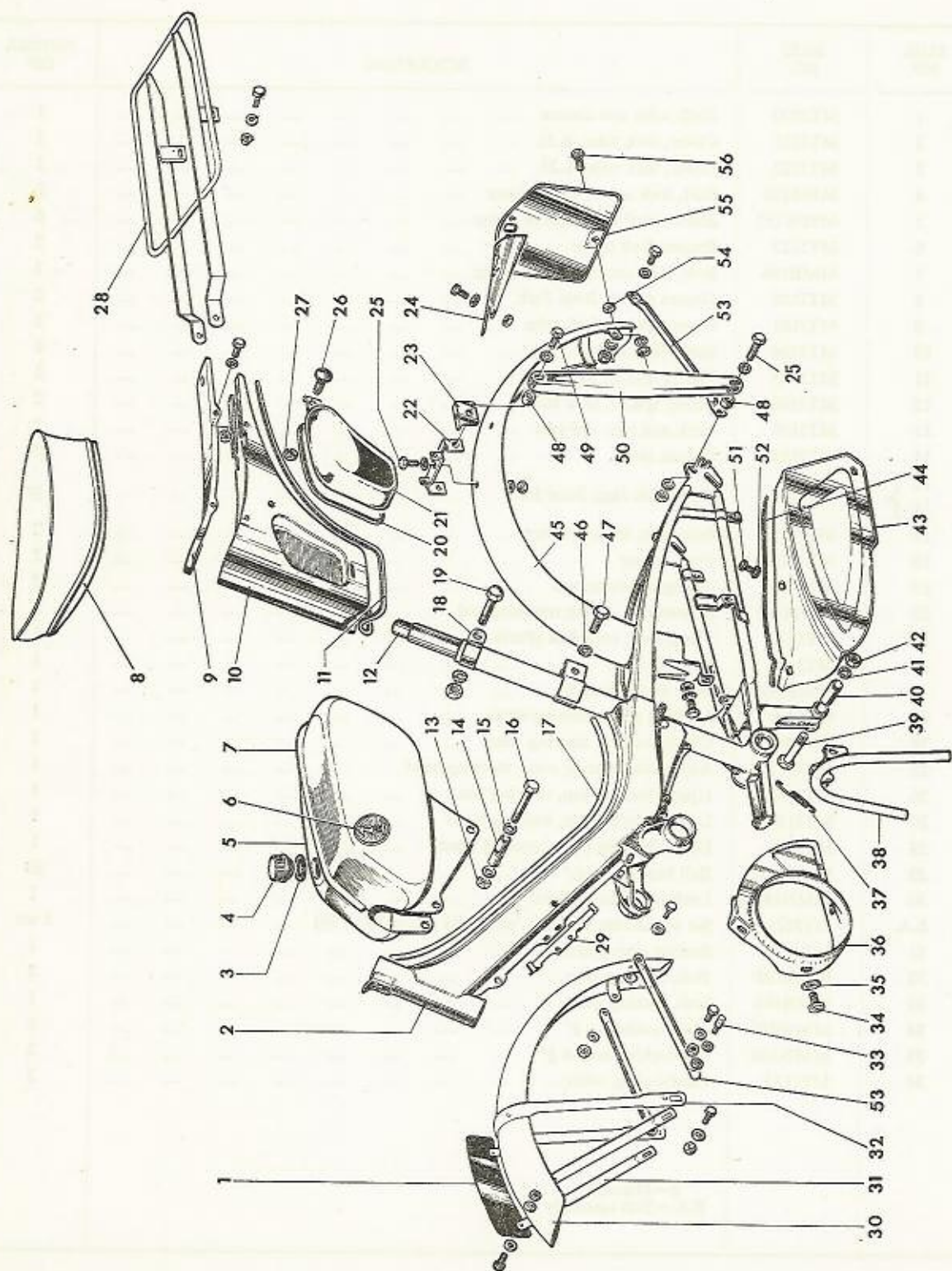

# FRAME GROUP 'G'

ILLUS. NO.	SALES NO.	DESCRIPTION	NUMBER OFF
1	MTL128	Front number plate ... ..	1
2	MTF204	Frame ... ..	1
3	MMW372	Sealing washer, filler cap ... ..	1
4	MTL102	Filler cap ... ..	1
5	MTL455	Fuel tank, c/w badges ... ..	1
6	MTL203	"Raleigh" badge ... ..	2
7	MTL367	Plastic trim strip, fuel tank ... ..	1
8	MTL458	Saddle ... ..	1
9	MTL454	Cover, seat tube fairing ... ..	1
10	MTL448	Fairing, seat tube ... ..	1
11	MTL113	Plastic trim strip, seat tube fairing ... ..	1
12	MTF105	Seat pillar ... ..	1
13	MMN189	Nut, tank mounting bolt ... ..	3
14	MTL366	Spacer, tank mounting bolt ... ..	2
15	MMW101	Plain washer, $\phi \frac{1}{2}$ ", tank mounting bolt ... ..	4
16	MMB203	Bolt, tank mounting ... ..	2
17	MTF125	Plastic trim strip, frame ... ..	1
18	MTF107	Clip, seat pillar ... ..	1
19	MMP138	Bolt, c/w nut and washer, seat pillar clip ... ..	1
20	MTL116	Plastic trim strip, tool box ... ..	2
21	MTL363	Tool box lid, L.H.... ... ..	1
N.I.	MTL362	Tool box lid, R.H. ... ..	1
22	MTL453	Bracket, carrier support stay ... ..	1
23	MTL452	Cover, support stay bracket ... ..	2
24	MTL388	Tailpiece ... ..	1
25	MMB117	Bolt, $\phi \frac{3}{8} \times \frac{3}{8}$ " ... ..	3
26	MTL117	Screw, toolbox lid ... ..	2
27	MTL118	Circlip, toolbox lid ... ..	2
28	MTL457	Rear luggage carrier ... ..	1
29	MTF111	Bracket, cable retaining ... ..	1
30	MTL449	Front mudguard ... ..	1
31	MTL288	Stay, upper, front mudguard ... ..	1
32	MTL289	Support stay, centre, front mudguard ... ..	1
33	MMP149	Cable stop bolt, c/w washer and nut ... ..	1
34	MMB214	Screw, clutch fairing ... ..	3
35	MMW289	Plastic washer, clutch fairing screw ... ..	3
36	MTL381	Clutch fairing ... ..	1
37	MTF123	Spring, centre stand ... ..	1
38	MTF164	Centre stand ... ..	1
39	MMP136	Bolt, c/w nut and washer, centre stand ... ..	1
40	MTF103	Spacer, centre stand ... ..	1
41	MMW182	Shakeproof washer, $\phi 7$ mm., centre stand bolt ... ..	1
42	MMN154	Nut, $\phi 7$ mm., centre stand bolt ... ..	1



# FRAME GROUP 'G'

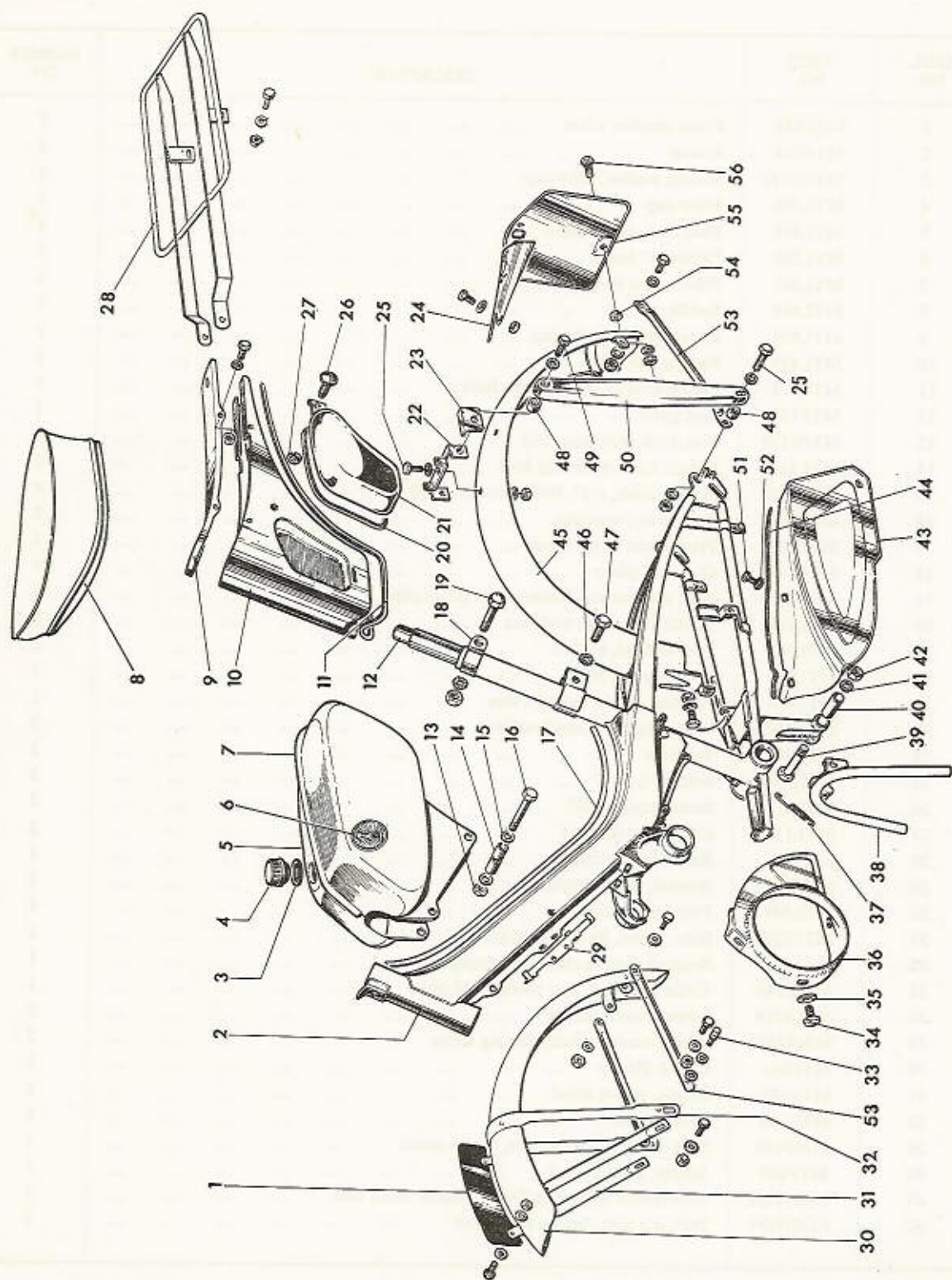

# FRAME GROUP 'G'

ILLUS. NO.	SALES NO.	DESCRIPTION	NUMBER OFF
43	MTL447	Fairing, L.H. ... ..	1
N.I.	MTL446	Fairing, R.H. ... ..	1
N.I.	MTL396	Transfer, "Raleigh," fairings ... ..	2
44	MTL149	Edging strip, L.H. fairing ... ..	1
N.I.	MTL151	Edging strip, R.H. fairing ... ..	1
45	MTL450	Rear mudguard ... ..	1
46	MMW337	Shakeproof washer, $\varnothing \frac{1}{8}"$ ... ..	2
47	MMB275	Bolt, seat tube fairing ... ..	2
48	MTL119	Distance piece, $\frac{1}{4}"$ long, support stay ... ..	5
49	MMB140	Bolt, $\varnothing \frac{3}{16}" \times \frac{1}{2}"$ , support stay ... ..	2
50	MTL456	Support stay, rear carrier ... ..	2
51	MMB336	Fairing screw ... ..	6
52	MMW237	Shakeproof washer, fairing screw ... ..	6
53	MTL283	Stay, mudguard ... ..	4
54	MMW139	Spacing washer, $\varnothing \frac{3}{16}" \times \frac{1}{8}"$ thick... ..	1
55	MTL123	Rear number plate ... ..	1
56	MMB140	Bolt, $\varnothing \frac{3}{16}" \times \frac{1}{2}"$ , rear number plate ... ..	1
<p>The nuts, bolts and washers not numbered on this illustration are as follows:—</p>			
N.N.	MMB206	Bolt, $\varnothing \frac{3}{16}" \times \frac{1}{2}"$ ... ..	15
N.N.	MMN219	Locknut, $\varnothing \frac{3}{16}"$ ... ..	22
N.N.	MMW105	Plain washer, $\varnothing \frac{3}{16}"$ ... ..	24
N.N.	MMW233	Spring washer, $\varnothing \frac{3}{16}"$ ... ..	4
<p><math>\varnothing</math> = Diameter  N.I. = Not illustrated  N.N. = Not numbered</p>			



# FRONT WHEEL GROUP 'H'

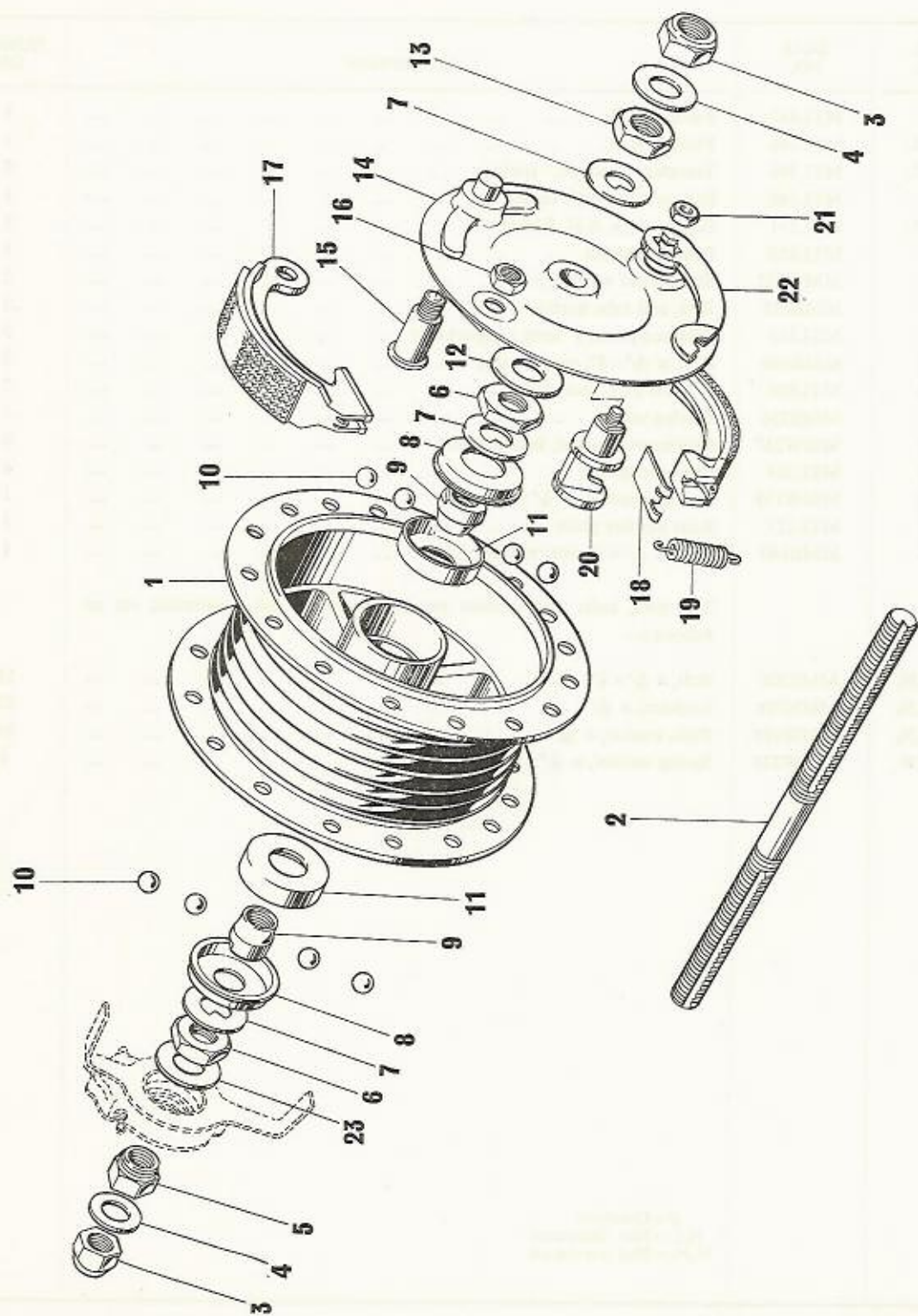

# FRONT WHEEL GROUP 'H'

ILLUS. NO.	SALES NO.	DESCRIPTION	NUMBER OFF
N.I.	MTK104	Spoke Nipple ... ..	36
N.I.	MTK103	Spoke ... ..	36
N.I.	MTK102	Wheel rim, 23" x 2" ... ..	1
S.A.	MTK101	Front wheel, less tyre and tube ... ..	1
1	MTK109	Front hub, complete (Parts 1 to 22) ... ..	1
2	MTK110	Front wheel spindle ... ..	1
3	MMN196	Nut, front wheel spindle ... ..	2
4	MMW272	Washer, wheel spindle ... ..	2
5	MMN197	Shouldered nut, wheel spindle ... ..	1
6	MMN198	Locknut, bearing cone ... ..	2
7	MMW273	Keyed washer ... ..	3
8	MTK111	Dust cap, wheel bearing ... ..	2
9	MTK112	Cone, wheel bearing ... ..	2
10	MML103	Ball bearing, $\varnothing \frac{1}{4}$ " ... ..	20
11	MTK113	Cup, wheel bearing ... ..	2
12	MMW274	Spacing washer, brake plate ... ..	1
13	MMN199	Locknut, brake plate ... ..	1
14	MTK115	Brake plate, complete (Parts 14 to 22) ... ..	1
15	MTK116	Pivot pin, brake shoe ... ..	1
16	MMN200	Nut, brake shoe pivot pin ... ..	1
17	MTK117	Brake shoe, c/w lining ... ..	1 pr.
18	MTK118	End plate, brake shoe ... ..	2
19	MTK119	Return spring, brake shoe ... ..	2
20	MTK120	Brake cam, c/w nut ... ..	1
21	MMN201	Nut, brake cam ... ..	1
22	MTK121	Lever, brake cam ... ..	1
23	MTK122	Spacer, speedometer drive unit ... ..	1
S.A.	MTK123	Front wheel spindle, c/w cones and locknuts ... ..	1
N.I.	MTK124	Spacer (fitted in lieu of speedometer drive unit and MTK122) ... ..	1

$\varnothing$  = Diameter  
 N.I. = Not illustrated  
 S.A. = Sub assembly



# REAR WHEEL

# GROUP '1'

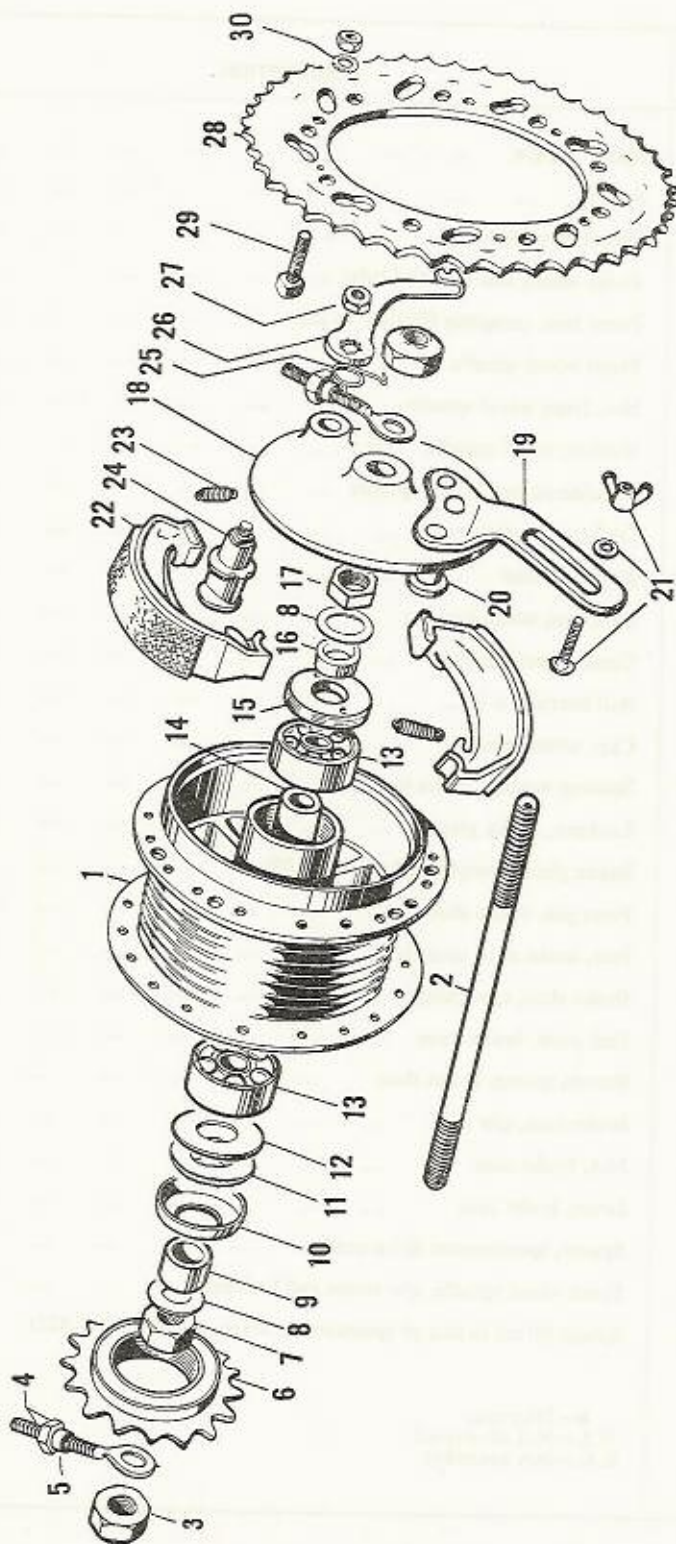

# REAR WHEEL GROUP '1'

ILLUS. NO.	SALES NO.	DESCRIPTION	NUMBER OFF
S.A.	MTK125	Rear wheel c/w sprockets, less tyre and tube ... ..	1
N.I.	MTK102	Wheel rim, 23" x 2" ... ..	1
N.I.	MTK126	Spoke ... ..	36
N.I.	MTK104	Spoke nipple ... ..	36
1	MTK128	Rear hub complete (Parts 1 to 30) ... ..	1
2	MTK130	Wheel spindle, rear ... ..	1
3	MMN202	Nut, rear wheel spindle ... ..	2
4	MTK131	Chain adjuster, c/w nut ... ..	2
5	MMN203	Nut, chain adjuster ... ..	2
6	MTK132	Freewheel, 18 teeth ... ..	1
7	MMN204	Locknut, 8 mm. thick ... ..	1
8	MMW275	Plain washer, spindle locknut ... ..	2
9	MTK133	Distance piece, 11 mm. long ... ..	1
10	MTK134	Retainer, felt seal ... ..	1
11	MTK135	Felt seal ... ..	1
12	MMW276	Shield washer, hub bearing ... ..	1
13	MTK136	Ball journal bearing ... ..	2
14	MTK137	Distance piece, hub bearings ... ..	1
15	MTK138	Screwed bearing retainer ... ..	1
16	MTK139	Distance piece, 6 mm. long ... ..	1
17	MMN205	Locknut, 5 mm. thick ... ..	1
18	MTK141	Brake plate complete (Parts 18 to 20 and 22 to 26) ... ..	1
19	MTK142	Torque arm, brake plate ... ..	1
20	MTK143	Fixed pivot, brake shoes ... ..	1
21	MMP145	Screw, c/w nut and washer, torque arm ... ..	1
22	MTK144	Brake shoe, c/w lining ... ..	1 pr.
23	MTK145	Return spring, brake shoe ... ..	2
24	MTK146	Brake cam, c/w nut ... ..	1
25	MTK186	Return spring, cam lever ... ..	1
26	MTK147	Lever, brake cam ... ..	1
27	MMN200	Nut, brake cam ... ..	1
28	MTK148	Drive sprocket, rear wheel ... ..	1
29	MMP146	Bolt and nut, drive sprocket ... ..	6
30	MMW266	Shakeproof washer, sprocket bolt ... ..	6

N.I. = Not illustrated  
S.A. = Sub assembly



# HANDLEBARS AND CONTROL CABLES

GROUP 'Ja'

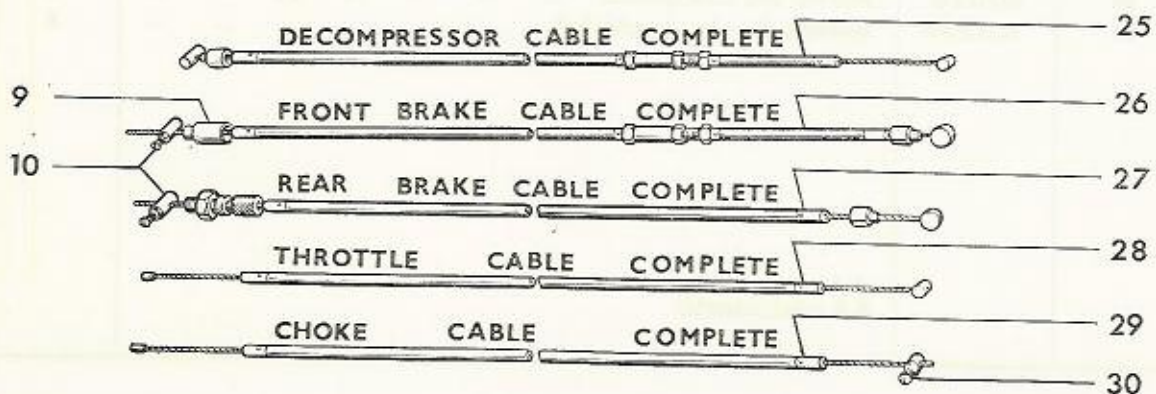
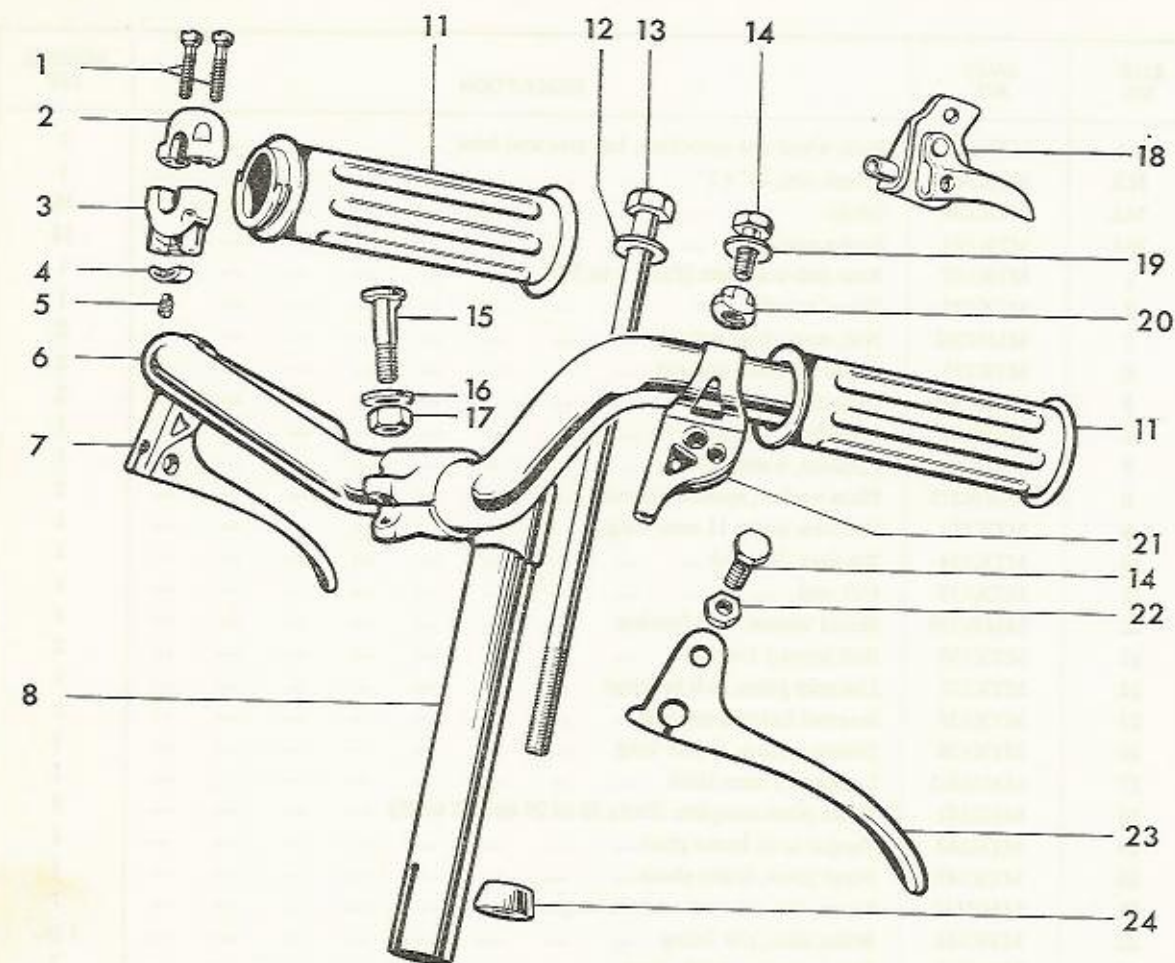

# HANDLEBARS AND CONTROL CABLES

# GROUP 'Ja'

ILLUS. NO.	SALES NO.	DESCRIPTION	NUMBER OFF
1	MMB273	Fixing screw, twistgrip ... ..	2
2	MTN111	Twistgrip body, top ... ..	1
3	MTN112	Twistgrip body, bottom ... ..	1
4	MTN113	Friction spring, twistgrip ... ..	1
5	MMB257	Screw, friction spring ... ..	1
S.A.	MTN114	Twistgrip, complete (Parts Nos. 1 to 5 and No. 11) ... ..	1
6	MTN101	Handlebar bend ... ..	1
7	MKM116	Brake fulcrum, R.H. ... ..	1
S.A.	MTN107	Brake lever, complete, R.H. (Parts Nos. 7, 14, 19, 20, 22 and 23) ... ..	1
8	MTN137	Handlebar stem, complete, with Parts Nos. 13, 15, 16 and 17 ... ..	1
9	MTN136	Ferrule, brake cable ... ..	2
10	MTN118	Solderless nipple ... ..	2
11	MTN245	Handlebar grip, plastic ... ..	1 pr.
12	MMW110	Washer, expander bolt ... ..	1
13	MTN255	Expander bolt, complete with cone and washer ... ..	1
14	MMB129	Bolt, lever fulcrum and clip ... ..	4
15	MMB108	Clamp bolt, handlebar ... ..	1
16	MMW109	Washer, handlebar clamp bolt ... ..	1
17	MMN109	Nut, handlebar clamp bolt ... ..	1
18	MTN115	Choke lever ... ..	1
19	MMW105	Plain washer, $\varnothing \frac{3}{16}$ " ... ..	2
20	MMN127	Nut, fulcrum clip ... ..	2
21	MKM117	Brake fulcrum, L.H. ... ..	1
S.A.	MTN108	Brake lever complete, L.H. (Parts Nos. 14, 19, 20, 21, 22 and 23) ... ..	1
22	MMN104	Nut, lever fulcrum ... ..	2
23	MTN106	Brake lever ... ..	2
24	MTN104	Expander cone ... ..	1
25	MTN134	Decompressor cable, complete ... ..	1
26	MTN116	Front brake cable, complete ... ..	1
27	MTN119	Rear brake cable, complete ... ..	1
28	MTN133	Throttle cable, complete ... ..	1
29	MTN135	Choke cable, complete ... ..	1
30	MTN125	Solderless nipple ... ..	1
N.I.	MTN126	Plastic sheath, control cables ... ..	2
N.I.	MTN253	Cable clip ... ..	1

$\varnothing$  = Diameter  
 N.I. = Not illustrated  
 S.A. = Sub assembly



# HANDLEBARS AND CONTROL CABLES (Later Models) GROUP 'Jb'

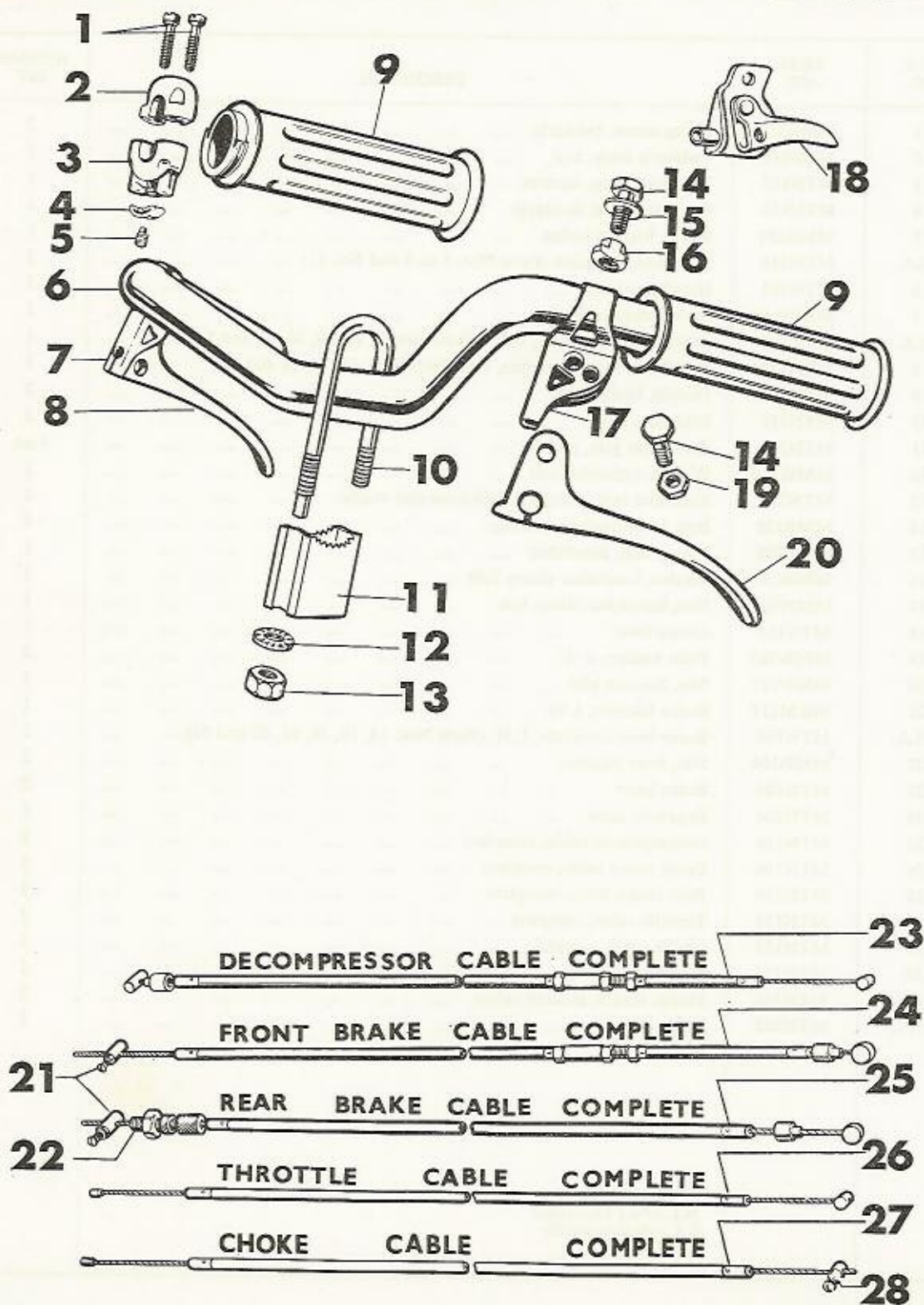

# HANDLEBARS AND CONTROL CABLES (Later Models) GROUP 'Jb'

ILLUS. No.	SALES NO.	DESCRIPTION	NUMBER OFF
1	MMB273	Fixing screw, twistgrip body ... ..	2
2	MTN111	Twistgrip body, top ... ..	1
3	MTN112	Twistgrip body, bottom ... ..	1
4	MTN113	Friction spring, twistgrip ... ..	1
5	MMB257	Screw, friction spring ... ..	1
S.A.	MTN114	Twistgrip, complete ... ..	1
6	MTN261	Handlebar bend ... ..	1
7	MKM116	Brake lever fulcrum, R.H. ... ..	1
8	MTN106	Brake lever, R.H. ... ..	1
S.A.	MTN107	Brake lever complete, R.H. c/w fulcrum and bolts ... ..	1
9	MTN245	Plastic grips (prs. only) ... ..	1 pr.
10	MMB286	"U" Bolts, handlebar mounting ... ..	2
11	MTN213	Spacer, handlebar mounting ... ..	2
12	MMW172	Washer, "U" bolt ... ..	4
13	MMN148	Nut, "U" bolt ... ..	4
S.A.	MTN218	Set of handle bar mountings ... ..	1
14	MMB129	Bolt, lever fulcrum and fulcrum clip ... ..	4
15	MMW105	Plain washer ... ..	2
16	MMN127	Nut, fulcrum clip ... ..	2
17	MKM117	Brake lever fulcrum, L.H. ... ..	1
18	MTN115	Choke lever, complete ... ..	1
19	MMN104	Nut, lever fulcrum ... ..	2
20	MTN106	Brake lever, L.H. ... ..	1
S.A.	MTN108	Brake lever complete, L.H. c/w fulcrum and bolts ... ..	1
21	MTN118	Solderless nipple ... ..	2
22	MTN250	Adjuster, rear brake cable ... ..	1
23	MTN122	Decompressor cable ... ..	1
24	MTN116	Front brake cable, complete ... ..	1
25	MTN119	Rear brake cable, complete ... ..	1
26	MTN121	Throttle cable, complete ... ..	1
27	MTN123	Choke cable, complete ... ..	1
28	MTN125	Solderless nipple, choke cable ... ..	1
N.I.	MTN126	Plastic sheath, control cables ... ..	1
N.I.	MNM112	Steering stem plug ... ..	1

S.A. = Sub assembly  
N.I. = Not illustrated



# LIGHTING, SPEEDOMETER AND ELECTRIC HORN GROUP 'K'

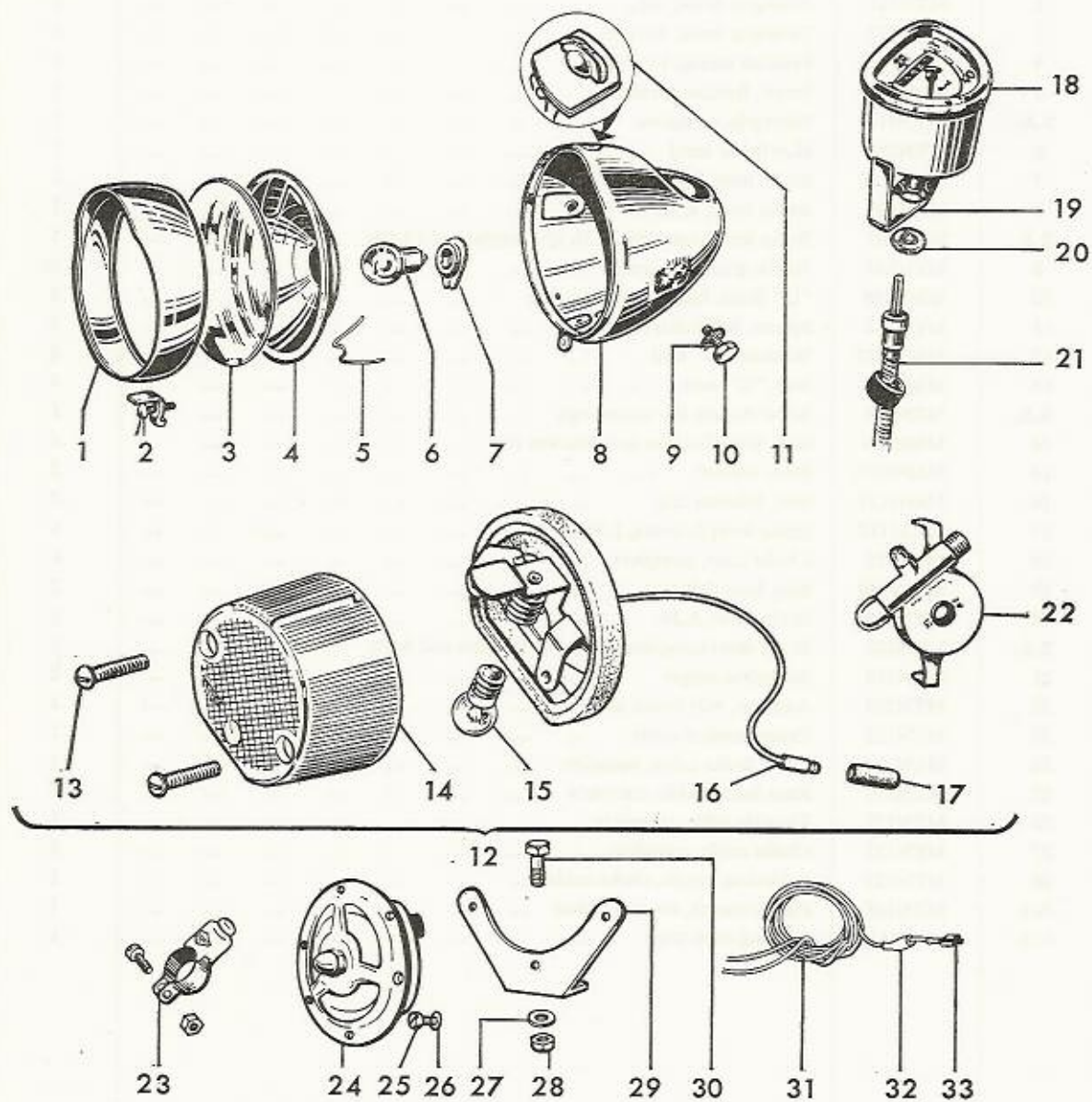

# LIGHTING, SPEEDOMETER AND ELECTRIC HORN GROUP 'K'

(THE SPEEDOMETER IS AN OPTIONAL EXTRA)

ILLUS. NO.	SALES NO.	DESCRIPTION	NUMBER OFF
1	MTP131	Headlamp rim ... ..	1
2	MTP132	Clip and screw, rim securing ... ..	1
3	MTP133	Headlamp lens ... ..	1
4	MTP134	Headlamp reflector ... ..	1
5	MTP135	Spring clip, reflector ... ..	4
6	MTP136	Headlamp bulb 6 v., 15 w., S.C.C. ... ..	1
7	MTP137	Bulb holder ... ..	1
8	MTP204	Headlamp, complete (Parts 1 to 11) ... ..	1
9	MMW314	Shakeproof washer, headlamp mounting ... ..	2
10	MMB248	Bolt, headlamp mounting ... ..	2
11	MTP129	Lighting switch, complete ... ..	1
12	MTP223	Tail lamp, complete ... ..	1
13	MMB335	Screw, tail lamp lens ... ..	2
14	MTP225	Lens, tail lamp ... ..	1
15	MTP116	Bulb, tail lamp, 6 v., 3 w., M.E.S. ... ..	1
16	MTP155	Connector nipple ... ..	2
17	MTP120	Rubber connector ... ..	1
18	MTR125	Speedometer head, M.P.H. ... ..	1
or 18	MTR320	Speedometer head, K.P.H. ... ..	1
19	MTR130	Bracket, speedometer head ... ..	1
20	MMN231	Nut, speedometer head ... ..	1
21	MTR142	Speedometer cable, complete ... ..	1
22	MTR144	Speedometer drive unit ... ..	1
23	MTP197	Horn button, c/w screw and nut ... ..	1
24	MTP123	Electric horn kit, c/w button, bracket and wiring ... ..	1
25	MMB300	Screw, horn to bracket ... ..	3
26	MMW359	Spring washer, horn to bracket screw ... ..	3
27	MMW101	Plain washer, horn mounting bolt ... ..	1
28	MMN189	Self-locking nut, horn mounting bolt ... ..	1
29	MTP124	Bracket, horn mounting ... ..	1
30	MMB194	Bolt, horn mounting ... ..	1
31	MTP229	Wiring harness ... ..	1
32	MTP162	Plastic cover, spade terminal ... ..	1
33	MTP161	Spade terminal ... ..	1
N.I.	MTR294	Blanking plate, speedometer aperture, headlamp ... ..	1

N.I.—Not illustrated



## TOOLKIT GROUP 'L'

SALES NO.	DESCRIPTION	NUMBER OFF
MTR101	Inflator ... ..	1
MTR102	Rubber connection, inflator ... ..	1
MTR105	Spanner, $\frac{1}{8}'' \times \frac{3}{16}'' \times \frac{1}{4}''$ B.S.F. ... ..	1
MTR107	Box spanner, sparking plug ... ..	1
MTR139	Ring spanner, $\frac{3}{8}'' \times \frac{1}{2}''$ B.S.F. ... ..	1
MTR106	Spanner, cylinder head nuts ... ..	1
MTR108	Spanner, 8 mm. $\times$ 10 mm. ... ..	1
MTR110	Combination spanner, 12 mm. $\times$ 14 mm. ... ..	1
MTR111	Combination spanner ... ..	1
MTR104	Tool wallet ... ..	1
MTR280	Set of spanners (original equipment) ... ..	1

## ACCESSORIES GROUP 'M'

SALES NO.	DESCRIPTION	NUMBER OFF
MTR251	Speedometer kit ... ..	1
MTR347	Legshield kit ... ..	1
MTR113	Windscreen ... ..	1
BYD682	Pannier bag ... ..	1

## SERVICE EXCHANGE GROUP 'N'

SALES NO.	DESCRIPTION	NUMBER OFF
MTX114	Engine unit, less magneto, clutch, carburettor, exhaust system and sparking plug ...	1
MTX115	Engine unit, complete with magneto, clutch and carburettor, but less sparking plug and exhaust system ... ..	1
MTX116	Carburettor, complete with air cleaner, but less control cables ... ..	1
MTX117	Crankshaft, complete with small end bearing and gudgeon pin ... ..	1
MTX167	Stator plate, complete with coils, contact breaker and condenser, but less external ignition coil ... ..	1
MTX118	Clutch, complete with variable gear ... ..	1
MTX108	Clutch shoes, relined ... ..	1 pr.
MTX133	Brake shoes, relined, front wheel ... ..	1 pr.
MTX110	Brake shoes, relined, rear wheel ... ..	1 pr.
MTX169	Frame, bare ... ..	1
	Clutch drum: no service exchange is available, but new leaf springs can be fitted at our works	

## CONDITIONS OF SERVICE EXCHANGE

This service enables the exchange replacement units listed to be readily available to the owners of our machines.

Thus off-the-road time can be cut to a minimum and the owner also has the benefit of a unit overhauled to the most rigorous standards and guaranteed by the factory.

The attention of all concerned is drawn to the following points:—

1. The fullest details should be quoted of the model and type of machine for which the replacement unit is required.
2. This service is essentially an exchange service and only provides for the supply of a standard replacement unit in exchange for the original. It does not provide for the overhaul and return of individual units or for the supply of advance replacements.
3. We cannot undertake to return to the previous owner any component part of a displaced unit and no allowance can be made in respect of any new material which may have been fitted to the unit prior to exchange.
4. All replacement units are built to standard specifications and an extra charge will be made at the current retail price in respect of any component deficient from the displaced unit.
5. We reserve the right to make an extra charge, based on the current retail price, in respect of any major component of the displaced unit found to be damaged or broken due to accident or to be beyond repair.
6. Only units built within the limits of the standard specifications can be supplied and orders stipulating any particular or special specifications cannot be accepted through the medium of this service.
7. It is helpful to remind owners of their statutory obligation to notify their local licensing authority of any change in frame or engine number which may be involved.



# SPECIAL WORKSHOP TOOLS

# GROUP 'O'

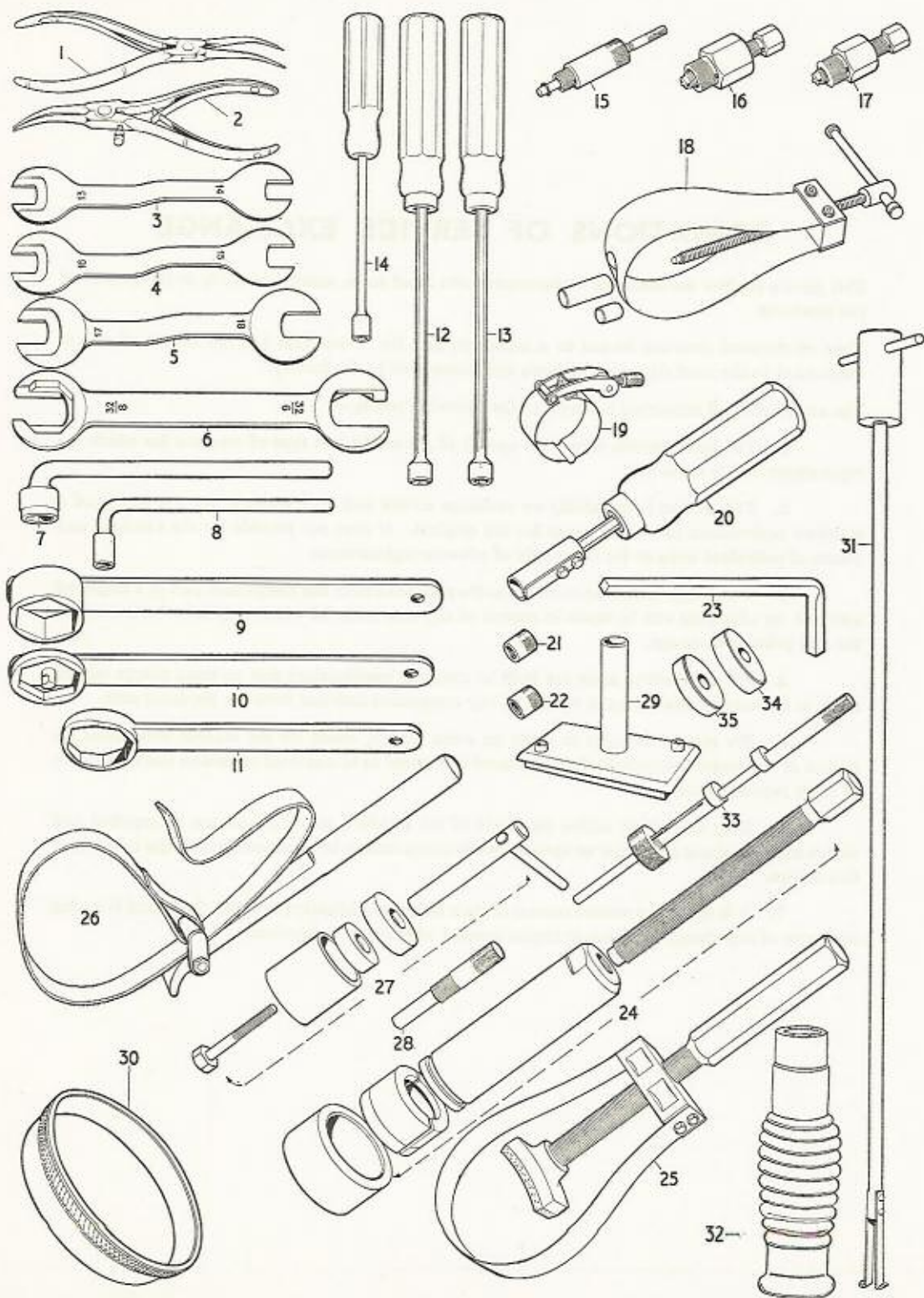

ILLUS. NO.	SALES NO.	DESCRIPTION
1	MTR218	Circlip pliers, internal type
2	MTR219	Circlip pliers, external type
3	MTR232	Cone spanner, 13×14 mm. A.F.
4	MTR233	Cone spanner, 15×16 mm. A.F.
5	MTR234	Cone spanner, 17×18 mm. A.F.
6	MTR230	Steering head locknut spanner, double ended
7	MTR215	Clutch drum nut wrench, 14 mm. A.F.
8	MTR221	Cylinder head nut wrench, 10 mm. A.F.
9	MTR216	Clutch hub nut wrench, 35 mm. A.F.
*10	MTR229	Steering head lower bolt spanner, 32 mm. A.F.
*11	MTR228	Steering head locknut spanner, 32 mm. A.F.
12	MTR225	Jet socket spanner, 9 mm. A.F.
13	MTR226	Jet socket spanner, 8 mm. A.F.
14	MTR227	Grease nipple socket spanner, 6 mm. A.F.
15	MTR182	Ignition advance gauge
16	MTR207	Magneto cam extractor
17	MTR208	Clutch drum extractor
18	MTR181	Gudgeon pin extractor
19	MTR223	Piston ring clamp
20	MTR217	Clutch key positioning tool
21	MTR209	Thread protector, 10 mm. R.H.
21	MTR281	Thread protector, 11 mm. R.H.
22	MTR210	Thread protector, 10 mm. L.H.
22	MTR211	Thread protector, 11 mm. L.H.
23	MTR212	Flywheel nut wrench, 10 mm. square
24	MTR224	Crankshaft bearing extractor
25	MTR214	Flywheel holding tool, steel band type
26	MTR213	Flywheel holding tool, webbing strap type
27	MTR231	Engine mounting rubber bush fitting tool
28	MTR180	Piston stop
29	MTR237	Clutch holding tool
30	MTR301	Coil centralising ring
31	MTR239	Fork bush removal tool
32	MTR241	Magnetic extractor for clutch washers
33	MTR242	Crankshaft—crankcase gauge
*34	MTR243	Dummy bearings, 42×15×13 mm.
35	MTR244	Dummy bearings, 42×16×13 mm.
*N.I.	MTR245	Rear hub bearing extractor
N.I.	MTR240	Replacement springs and rivets for MTR239 fork tool
N.I.	MTR247	Exhaust nut spanner

N.I. = Not illustrated

A.F. = Across flats

\* = Items marked thus are not applicable to this machine



# NUMERICAL INDEX

SALES NO.	GROUP	ILLUS. NO.	SALES NO.	GROUP	ILLUS. NO.	SALES NO.	GROUP	ILLUS. NO.			
BYD682	...	M	N.I.	MMN153	...	A	30	MMW203	...	B	N.I.
MKM116	...	Ja	7	MMN154	...	A	20	MMW204	...	B	N.I.
MKM116	...	Jb	7	MMN154	...	G	42	MMW205	...	B	N.I.
MKM117	...	Ja	21	MMN164	...	B	1	MMW207	...	B	18
MKM117	...	Jb	17	MMN171	...	E	35	MMW208	...	B	3
MMB108	...	Ja	15	MMN182	...	C	1	MMW231	...	E	6
MMB117	...	G	25	MMN187	...	F	20	MMW232	...	E	9
MMB129	...	Ja	14	MMN188	...	F	30	MMW233	...	E	34
MMB129	...	Jb	14	MMN189	...	F	35	MMW233	...	G	N.N.
MMB140	...	G	49	MMN189	...	G	13	MMW237	...	G	52
MMB140	...	G	56	MMN189	...	K	28	MMW245	...	C	30
MMB145	...	A	11	MMN196	...	H	3	MMW246	...	C	30
MMB146	...	A	13	MMN197	...	H	5	MMW251	...	C	2
MMB147	...	A	56	MMN198	...	H	6	MMW262	...	C	13
MMB149	...	A	65	MMN199	...	H	13	MMW263	...	C	15
MMB151	...	A	27	MMN200	...	H	16	MMW265	...	F	24
MMB152	...	A	53	MMN200	...	I	27	MMW266	...	I	30
MMB153	...	A	59	MMN201	...	H	21	MMW272	...	H	4
MMB154	...	A	24	MMN202	...	I	3	MMW273	...	H	7
MMB155	...	A	S.A.	MMN203	...	I	5	MMW274	...	H	12
MMB165	...	B	7	MMN204	...	I	7	MMW275	...	I	8
MMB171	...	E	33	MMN205	...	I	17	MMW276	...	I	12
MMB177	...	C	14	MMN219	...	G	N.N.	MMW289	...	G	35
MMB179	...	C	12	MMN226	...	D	27	MMW307	...	D	26
MMB180	...	C	21	MMN227	...	D	30	MMW308	...	D	7
MMB182	...	C	24	MMN231	...	K	20	MMW314	...	K	9
MMB192	...	F	22	MMN251	...	A	41	MMW337	...	G	46
MMB193	...	F	32	MMN276	...	E	21	MMW346	...	E	6
MMB194	...	F	33	MMN288	...	B	27	MMW347	...	E	6
MMB194	...	K	30	MMP130	...	A	18	MMW359	...	K	26
MMB195	...	F	4	MMP132	...	E	39	MMW361	...	B	19
MMB196	...	F	7	MMP135	...	E	13	MMW372	...	G	3
MMB203	...	G	16	MMP136	...	G	39	MTA105	...	A	37
MMB206	...	G	N.N.	MMP138	...	G	19	MTA106	...	A	36
MMB214	...	G	34	MMP144	...	C	27	MTA107	...	A	38
MMB236	...	D	12	MMP145	...	I	21	MTA108	...	A	45
MMB237	...	D	25	MMP146	...	I	29	MTA109	...	A	46
MMB238	...	D	8	MMP149	...	G	33	MTA110	...	A	39
MMB248	...	K	10	MMW101	...	F	34	MTA112	...	A	40
MMB257	...	Ja	5	MMW101	...	G	15	MTA116	...	A	49
MMB257	...	Jb	5	MMW101	...	G	15	MTA118	...	A	69
MMB273	...	Ja	1	MMW105	...	K	27	MTA121	...	A	51
MMB273	...	Jb	1	MMW105	...	G	N.N.	MTA122	...	A	32
MMB275	...	G	47	MMW105	...	Ja	19	MTA123	...	A	31
MMB286	...	Jb	10	MMW105	...	Jb	15	MTA124	...	A	31
MMB300	...	K	25	MMW109	...	Ja	16	MTA125	...	A	33
MMB335	...	K	13	MMW110	...	Ja	12	MTA126	...	A	34
MMB336	...	G	51	MMW139	...	G	54	MTA127	...	A	35
MML101	...	F	29	MMW157	...	E	41	MTA131	...	A	7
MML103	...	H	10	MMW157	...	F	5	MTA132	...	A	8
MML107	...	B	6	MMW164	...	A	42	MTA134	...	A	3
MMN104	...	Ja	22	MMW165	...	A	44	MTA135	...	A	4
MMN104	...	Jb	19	MMW167	...	A	28	MTA136	...	A	12
MMN109	...	Ja	17	MMW168	...	A	9	MTA139	...	A	15
MMN127	...	Ja	20	MMW169	...	A	9	MTA141	...	A	19
MMN127	...	Jb	16	MMW170	...	A	9	MTA145	...	A	N.I.
MMN147	...	A	66	MMW171	...	A	5	MTA146	...	A	N.I.
MMN148	...	A	1	MMW172	...	Jb	12	MTA149	...	A	63
MMN148	...	Jb	13	MMW173	...	A	6	MTA150	...	A	43
MMN149	...	A	16	MMW180	...	A	2	MTA152	...	A	47
MMN152	...	A	29	MMW181	...	A	54	MTA154	...	A	48
				MMW182	...	A	21	MTA155	...	A	50
				MMW182	...	G	41	MTA156	...	A	68
				MMW202	...	B	13	MTA157	...	A	67

# NUMERICAL INDEX

SALES NO.	GROUP	ILLUS. NO.	SALES NO.	GROUP	ILLUS. NO.	SALES NO.	GROUP	ILLUS. NO.			
MTA161	...	A	52	MTD210	...	E	1	MTJ122	...	F	31
MTA162	...	A	14	MTD211	...	E	8	MTJ123	...	F	36
MTA163	...	A	55	MTD216	...	E	29	MTJ127	...	F	6
MTA165	...	A	58	MTD220	...	E	25	MTJ128	...	F	8
MTA166	...	A	60	MTD221	...	E	22	MTJ177	...	F	15/16
MTA167	...	A	61	MTD245	...	E	11	MTJ192	...	F	21
MTA168	...	A	17	MTD248	...	E	30	MTJ196	...	F	13
MTA169	...	A	23	MTD249	...	E	7	MTJ220	...	F	1
MTA171	...	A	22	MTD251	...	E	14	MTJ221	...	F	2
MTA174	...	A	S.A.	MTD253	...	E	12	MTJ222	...	F	3
MTA283	...	A	57	MTD256	...	E	10	MTJ223	...	F	S.A.
MTA304	...	A	25/26	MTD257	...	E	23	MTK101	...	H	S.A.
MTA305	...	A	25/26	MTD258	...	E	20	MTK102	...	H	N.I.
MTA306	...	A	25/26					MTK102	...	I	N.I.
MTA307	...	A	25/26	MTF103	...	G	40	MTK103	...	H	N.I.
MTA308	...	A	64	MTF105	...	G	12	MTK104	...	H	N.I.
MTA309	...	A	62	MTF107	...	G	18	MTK104	...	I	N.I.
MTA310	...	A	10	MTF111	...	G	29	MTK109	...	H	1
MTA316	...	A	N.I.	MTF123	...	G	37	MTK110	...	H	2
MTA317	...	A	N.I.	MTF125	...	G	17	MTK111	...	H	8
MTA318	...	A	N.I.	MTF164	...	G	38	MTK112	...	H	9
MTA319	...	A	N.I.	MTF204	...	G	2	MTK113	...	H	11
MTA320	...	A	N.I.					MTK115	...	H	14
				MTH106	...	C	11	MTK116	...	H	15
MTB106	...	B	23	MTH110	...	C	19	MTK117	...	H	17
MTB107	...	B	14	MTH111	...	C	20	MTK118	...	H	18
MTB108	...	B	24	MTH137	...	C	28	MTK119	...	H	19
MTB109	...	B	28	MTH138	...	C	16	MTK120	...	H	20
MTB110	...	B	10	MTH139	...	C	18	MTK121	...	H	22
MTB112	...	B	20	MTH140	...	C	17	MTK122	...	H	23
MTB117	...	B	15	MTH141	...	C	3	MTK123	...	H	S.A.
MTB118	...	B	16	MTH142	...	C	4	MTK124	...	H	N.I.
MTB119	...	B	26	MTH146	...	C	8	MTK125	...	I	S.A.
MTB120	...	B	2	MTH147	...	C	7	MTK126	...	I	N.I.
MTB121	...	B	4	MTH148	...	C	9	MTK128	...	I	1
MTB122	...	B	5	MTH149	...	C	22	MTK130	...	I	2
MTB123	...	B	8	MTH150	...	C	10	MTK131	...	I	4
MTB124	...	B	21	MTH151	...	C	25	MTK132	...	I	6
MTB125	...	B	12	MTH152	...	C	23	MTK133	...	I	9
MTB126	...	B	22	MTH153	...	C	23	MTK134	...	I	10
MTB127	...	B	11	MTH154	...	C	23	MTK135	...	I	11
MTB128	...	B	9	MTH195	...	C	31	MTK136	...	I	13
MTB130	...	B	17	MTH196	...	C	32	MTK137	...	I	14
MTB152	...	B	S.A.	MTH197	...	C	33	MTK138	...	I	15
MTB156	...	B	25	MTH210	...	C	5	MTK139	...	I	16
				MTH211	...	C	6	MTK141	...	I	18
MTD177	...	E	32	MTH213	...	C	26	MTK142	...	I	19
MTD179	...	E	31	MTH214	...	C	S.A.	MTK143	...	I	20
MTD181	...	E	5	MTH216	...	C	35	MTK144	...	I	22
MTD184	...	E	27	MTH217	...	C	29	MTK145	...	I	23
MTD185	...	E	28					MTK146	...	I	24
MTD188	...	E	16	MTJ103	...	F	9	MTK147	...	I	26
MTD189	...	E	17	MTJ104	...	F	10	MTK148	...	I	28
MTD190	...	E	15	MTJ105	...	F	11	MTK186	...	I	25
MTD191	...	E	24	MTJ106	...	F	12				
MTD192	...	E	26	MTJ108	...	F	14	MTL102	...	G	4
MTD195	...	E	18	MTJ111	...	F	17	MTL113	...	G	11
MTD196	...	E	19	MTJ112	...	F	18	MTL116	...	G	20
MTD197	...	E	3	MTJ113	...	F	19	MTL117	...	G	26
MTD198	...	E	4	MTJ116	...	F	23	MTL118	...	G	27
MTD199	...	E	2	MTJ117	...	F	25	MTL119	...	G	48
MTD201	...	E	37	MTJ118	...	F	26	MTL123	...	G	55
MTD202	...	E	40	MTJ119	...	F	27	MTL128	...	G	1
MTD203	...	E	38	MTJ120	...	F	28	MTL149	...	G	44
MTD204	...	E	36	MTJ121	...	F	S.A.	MTL151	...	G	N.I.



# NUMERICAL INDEX

SALES NO.	GROUP	ILLUS. NO.	SALES NO.	GROUP	ILLUS. NO.	SALES NO.	GROUP	ILLUS. NO.			
MTL203	...	G	6	MTN113	...	Ja	4	MTR110	...	L	N.I.
MTL270	...	C	34	MTN113	...	Jb	4	MTR111	...	L	N.I.
MTL283	...	G	53	MTN114	...	Ja	S.A.	MTR113	...	M	N.I.
MTL288	...	G	31	MTN114	...	Jb	S.A.	MTR125	...	K	18
MTL289	...	G	32	MTN115	...	Ja	18	MTR130	...	K	19
MTL362	...	G	N.I.	MTN115	...	Jb	18	MTR139	...	L	N.I.
MTL363	...	G	21	MTN116	...	Ja	26	MTR142	...	K	21
MTL366	...	G	14	MTN116	...	Jb	24	MTR144	...	K	22
MTL367	...	G	7	MTN118	...	Ja	10	MTR180	...	O	28
MTL381	...	G	36	MTN118	...	Jb	21	MTR181	...	O	18
MTL388	...	G	24	MTN119	...	Ja	27	MTR182	...	O	15
MTL396	...	G	N.I.	MTN119	...	Jb	25	MTR207	...	O	16
MTL446	...	G	N.I.	MTN121	...	Jb	26	MTR208	...	O	17
MTL447	...	G	43	MTN122	...	Jb	23	MTR209	...	O	21
MTL448	...	G	10	MTN123	...	Jb	27	MTR210	...	O	22
MTL449	...	G	30	MTN125	...	Ja	30	MTR211	...	O	22
MTL450	...	G	45	MTN125	...	Jb	28	MTR212	...	O	23
MTL452	...	G	23	MTN126	...	Ja	N.I.	MTR213	...	O	26
MTL453	...	G	22	MTN126	...	Jb	N.I.	MTR214	...	O	25
MTL454	...	G	9	MTN133	...	Ja	28	MTR215	...	O	7
MTL455	...	G	5	MTN134	...	Ja	25	MTR216	...	O	9
MTL456	...	G	50	MTN135	...	Ja	29	MTR217	...	O	20
MTL457	...	G	28	MTN136	...	Ja	9	MTR218	...	O	1
MTL458	...	G	8	MTN137	...	Ja	8	MTR219	...	O	2
				MTN213	...	Jb	11	MTR221	...	O	8
MTM129	...	D	4	MTN218	...	Jb	S.A.	MTR223	...	O	19
MTM131	...	D	10	MTN245	...	Ja	11	MTR224	...	O	24
MTM132	...	D	9	MTN245	...	Jb	9	MTR225	...	O	12
MTM133	...	D	11	MTN250	...	Jb	22	MTR226	...	O	13
MTM134	...	D	6	MTN253	...	Ja	N.I.	MTR227	...	O	14
MTM135	...	D	23	MTN255	...	Ja	13	MTR228	...	O	11
MTM136	...	D	22	MTN261	...	Jb	6	MTR229	...	O	10
MTM137	...	D	3					MTR230	...	O	6
MTM138	...	D	1	MTP116	...	K	15	MTR231	...	O	27
MTM139	...	D	28	MTP120	...	K	17	MTR232	...	O	3
MTM143	...	D	16	MTP123	...	K	24	MTR233	...	O	4
MTM144	...	D	15	MTP124	...	K	29	MTR234	...	O	5
MTM145	...	D	17	MTP129	...	K	11	MTR237	...	O	29
MTM146	...	D	18	MTP131	...	K	1	MTR239	...	O	31
MTM147	...	D	19	MTP132	...	K	2	MTR240	...	O	N.I.
MTM148	...	D	20	MTP133	...	K	3	MTR241	...	O	32
MTM153	...	D	2	MTP134	...	K	4	MTR242	...	O	33
MTM154	...	D	21	MTP135	...	K	5	MTR243	...	O	34
MTM157	...	D	5	MTP136	...	K	6	MTR244	...	O	35
MTM164	...	D	S.A.	MTP137	...	K	7	MTR245	...	O	N.I.
MTM165	...	D	29	MTP155	...	K	16	MTR247	...	O	N.I.
MTM166	...	D	24	MTP161	...	D	13	MTR251	...	M	N.I.
MTM167	...	D	S.A.	MTP161	...	K	33	MTR280	...	L	N.I.
MTM168	...	D	N.I.	MTP162	...	D	14	MTR281	...	O	21
				MTP162	...	K	32	MTR294	...	K	N.I.
MTN101	...	Ja	6	MTP197	...	K	23	MTR301	...	O	30
MTN104	...	Ja	24	MTP204	...	K	8	MTR320	...	K	18
MTN106	...	Ja	23	MTP223	...	K	12	MTR347	...	M	N.I.
MTN106	...	Jb	8	MTP225	...	K	14				
MTN106	...	Jb	20	MTP229	...	K	31	MTX108	...	N	N.I.
MTN107	...	Ja	S.A.					MTX110	...	N	N.I.
MTN107	...	Jb	S.A.	MTR101	...	L	N.I.	MTX114	...	N	N.I.
MTN108	...	Ja	S.A.	MTR102	...	L	N.I.	MTX115	...	N	N.I.
MTN108	...	Jb	S.A.	MTR104	...	L	N.I.	MTX116	...	N	N.I.
MTN111	...	Ja	2	MTR105	...	L	N.I.	MTX117	...	N	N.I.
MTN111	...	Jb	2	MTR106	...	L	N.I.	MTX118	...	N	N.I.
MTN112	...	Ja	3	MTR107	...	L	N.I.	MTX133	...	N	N.I.
MTN112	...	Jb	3	MTR108	...	L	N.I.	MTX167	...	N	N.I.
								MTX169	...	N	N.I.

# IceniCAM Information Service

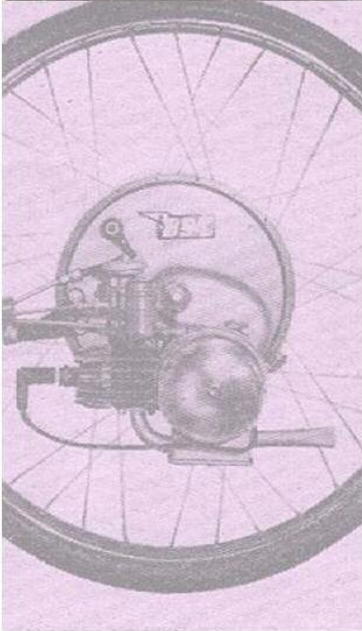

[www.icenicam.org.uk](http://www.icenicam.org.uk)