

Mobylette

*Repair
Manual*

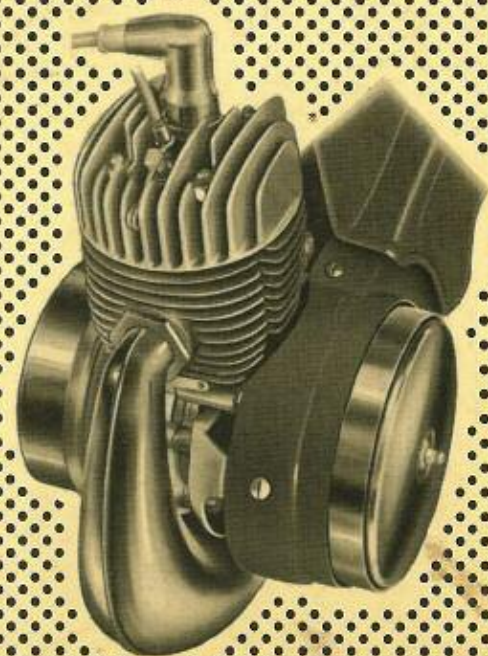

Mobylette

↓ 1.00

NOTICE

All along this manual, references are made to units of measurement with which you may not be familiar.

Therefore we take this opportunity to remind you that :

1 mm (millimeter) = 0,039 inch.

1 cm (centimeter) = 10 mm = 0,394 inch.

LIST OF CONTENTS GROUPED BY OPERATIONS

Description and main data of the Mobylette engines	5	Complete engine re-assembly (continuation) (fitting the piston in the cylinder and straightening a rod)	29
Tool board N° 1	6	Complete engine re-assembly (continuation) straightening a rod	30
List of tooling N° 1	7	Speed variator (description and operation)	31
Tool board N° 2	8	Complete disassembly of a variator (operation n° 12)	32
List of tooling N° 2	9	Re-assembling a variator	33
Tooling for all types of Mobylette cycles	10	Complete disassembly of a variator with unthreaded fixed cheek (operation n° 14)	34
Engine stand (swiveling)	11	Re-assembling a variator with unscrewed fixed cheek (operation n° 15)	35
Stroke limiter	12	Complete disassembly of a DIMOBY clutch (operation n° 16)	36
Belt drive (special recommendation)	13	Re-assembling a DIMOBY clutch (operation n° 17)	36
Removing a fixed engine (operation n° 1)	14	Adjusting a DIMOBY clutch without variator (operation n° 18)	36
Refitting a repaired (fixed) engine (operation n° 2)	15	Cycle section	37
Removing a hinged variator engine (operation n° 3)	16	Sketch of a repair bench	38
Refitting a repaired engine (operation n° 4)	17	Repairing a rigid fork or replacing a steering unit (operation n° 19)	39
Removing a flywheel magneto (operation n° 5)	18	Repairing or replacing a telescopic fork (operation n° 20)	40
Refitting a flywheel magneto (operation n° 6, adjusting the contact breaker)	19	Complete disassembly of the telescopic forks (operation n° 21)	41
Refitting a flywheel magneto (continuation n° 1) (operation n° 6, ignition timing)	20	Repairing a lever action fork (operation n° 22)	42
Centering the armatures on the flywheel magneto mounting plate	21	Replacing a pulley and a bottom bracket spindle (operation n° 23)	43
Removing a variator or a DIMOBY clutch (operations n° 7 and 8)	22	Replacing the bottom bracket spindle bushings (operation n° 24)	44
Refitting a variator or a DIMOBY clutch (operation n° 9)	23	Disassembling or re-assembling — a) Engine hinge flexibloc mounts	
Refitting a variator or a DIMOBY clutch (continuation)	24	b) Hub bearings	45
Marking cylinders and pistons	25	Poor performance	46
Complete disassembly of a Mobylette engine (operation n° 10)	26	Poor ignition operation	47
Complete engine re-assembly (operation n° 11, side play adjustment and crankshaft assembly in the crankcases)	27	Poor ignition operation (continuation)	48
Complete engine re-assembly (continuation)	28		

TABLE OF CONTENTS GROUPED BY COMPONENTS

BELT	PAGE
Tension	13
Special recommendation	13
BOTTOM BRACKET PULLEY	
Replacing a bottom bracket pulley and spindle	43
Replacing bottom bracket spindle bushings	44
CLUTCH	
Removal	22
Refitting	23-24
Disassembly	36
Re-assembly	36
Adjustment	36
ENGINE	
Engine description and main data	5
Removal { Fixed engine	14
{ Repaired engine	16
Refitted { Fixed engine	15
{ Hinged engine	17
Complete disassembly	26
Complete re-assembly	27-28-29-30
Replacing the crankshaft in the crankcases	27
Fitting the piston in the cylinder	29
Straightening a rod	30
Poor performance	46

FORK	PAGE
Repair of a rigid fork	39
Replacing a steering unit	39
Repairing or replacing a telescopic fork	40
Complete disassembly of a telescopic fork	41
Repair of a lever action fork	42
HUBS	
Removal of the bearings	45
MAGNETIC FLYWEIGHT	
Removal	18
Refitting	19-20
Ignition timing adjustment	20
Centering the armature	21
Ignition trouble shooting	47-48
UPPER HINGE "FLEXIBLOCS"	
Disassembly and re-assembly	45
VARIATOR	
Description and operation	31
Removal	22
Refitting	23-24
Disassembly { with fixed screwed cheek	32
{ with fixed unthreaded cheek	34
Re-assembly { with fixed screwed cheek	33
{ with fixed unthreaded cheek	35
Adjustment	36

DESCRIPTION AND MAIN DATA OF THE MOBYLETTE ENGINES

ENGINE TYPE	AV or AU MACHINE	GURTNER CARBURETTOR	COMPRESSION RATIO	ADVANCED SPARK (mm)	DRIVE
AV 7 S FIXED	32 S	516	6,5	3	Clutchless
AV 7 Sb FIXED	41	516	6,5	3	Clutchless
AV 7 De FIXED	85 - 65 - 76	540 - 610 **	7,5	2	DIMOBY clutch
AV 7 Db FIXED	42	540 - 610 **	6,5	3	DIMOBY clutch
AV 7 Dbe FIXED	44	540 - 610 **	7,5	2	DIMOBY clutch
AV 7 Dbg FIXED	BG or CG 43 - 44	525	6,5	3	DIMOBY clutch
AV 7 V HINGED	68 - 79	549	7,5	2	Variator with DIMOBY
AV 7 Vb HINGED	48	549	7,5	2	Variator with DIMOBY
AV 7 V 2 HINGED	88	488	7,5	2	Variator with DIMOBY
AV 7 V 2,5 HINGED	89 - SP 50 - SP 50 R	569	9	1,5	Variator with DIMOBY
AV 7 V. 2,5 S* HINGED	SP 50 R°	569	9	1,5	Variator with DIMOBY
AV 7 V 2,5 B	AV 98	626	9	1,5	Variator with DIMOBY

** - Adjustment 540 is superseded by adjustment 610.

TOOL BOARD N° 1

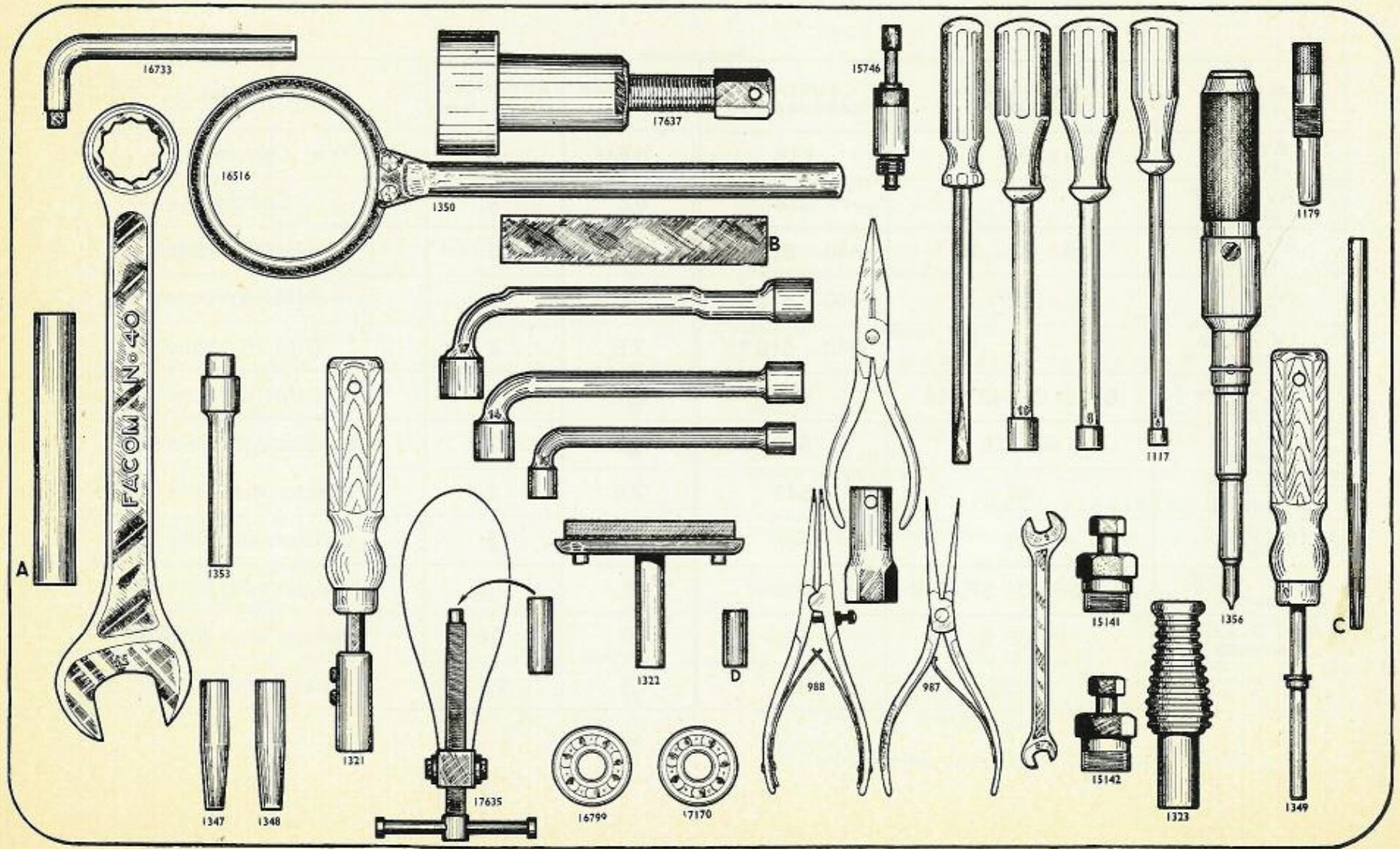

LIST OF TOOLS N° 1 (Part N° 1371)

This is a large set of tools intended to dealers who wish to own a very complete equipment
REQUIRED IN DISASSEMBLING, REPAIRING AND RE-ASSEMBLING THE VARIOUS MOBYLETTE ENGINES

Part N°	DESCRIPTION AND FUNCTION	SUPPLIER	SUPPLIER'S PART N°	Part N°	DESCRIPTION AND FUNCTION	SUPPLIER	SUPPLIER'S PART N°
987	Truarc closing pliers	Var	420	16.516	Armature centering bush	MB	8.119
988	Truarc opening pliers	Var	430	16.733	Square tipped wrench for flywheel square-head nut	Var	341
1.117	Clutch or variator nipple wrench	Var	367	16.799	15 mm. dia. crankshaft dummy bearing	MB	
1.179	Piston stroke limiter	Var	394	17.170	16 mm. dia. crankshaft dummy bearing	MB	
1.321	Clutch or variator cotter adaptor	Var	347	17.635	Piston pin drift	Var	68
1.322	Tool for disassembling variator	Var	348	17.637	Crankshaft bearing extractor	Var	142/42
1.323	Magnetic extractor	Var	344	17.645	Engine disassembly and re-assembly stand	Var	378
1.347	11 mm. dia. centering pin for clutch and variator	Var	395		End wrench, I.D. 8 mm., O.D. 9 mm.	Facom	33
1.348	10 mm. dia. centering pin for clutch and variator	Var	395 ^{bis}		35 mm. dual wrench	Facom	40
1.349	Piston pin adaptor	Var	396		14 mm. socket wrench	Facom	72
1.350	Clamp for disassembling fixed cheek screwed on variator	Var	398		10 mm. socket wrench	Facom	72
1.351	Belt tensioning tool	Var	343		10 mm. box wrench	Facom	74
1.353	Crankcase oil seal adaptor	Var	399		8 mm. box wrench	Facom	74
1.355	Piston ring pliers	Var	261		17 mm. open socket wrench	Facom	75
1.356	Screwdriver (hammer driven)	Var	298		Flat nose pliers	Facom	188
1.359	" Gazecom " torch	Var	350	A	Screwdriver	Facom	224
1.360	Engine pulley pin wrench	Var	389	B	Tube I.D. 18 mm., O.D. 22 mm., 150 mm lg		
15.141	Clutch and variator drum extractor, 24 mm. dia. x 100 mm. lg	Var	362	C	120 x 30 x 7 mm. mild steel strip		
15.142	Flywheel cam extractor, 26 mm. dia. x 100 mm. lg	Var	359	D	Steel broach for straightening rod, etc., 210 mm. lg, 10 mm. dia., tapered length 70 mm., 7,5 mm. end dia.		
15.746	Ignition timing feeler gauge	Var	239		Dummy piston pin, O.D. 12,9 mm. (used with piston pin adaptor 1349).		

The opposite page shows the tools required for engine disassembly and re-assembly.

TOOL BOARD N° 2

Mobylette

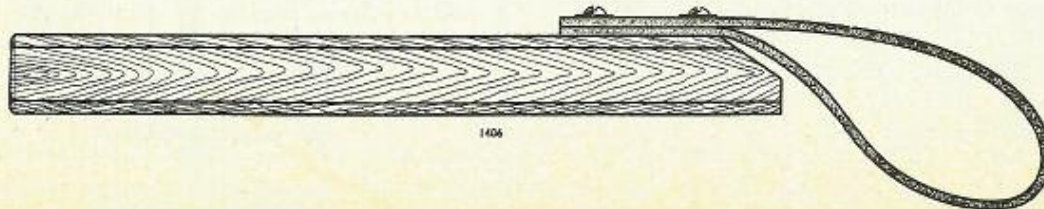
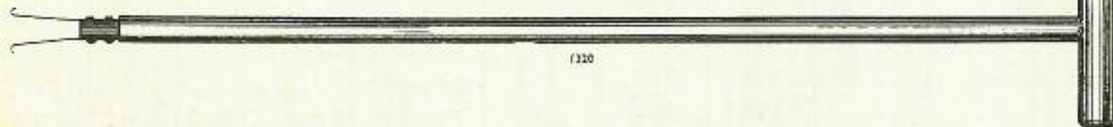
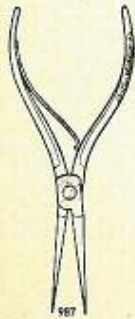
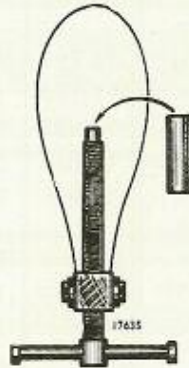

LIST OF TOOLS N° 2 (Part n° 1375)

This is a special set of tools intended to dealers who wish to own only what is strictly required to maintain and repair Mobylettes

REQUIRED IN DISASSEMBLING, REPAIRING AND RE-ASSEMBLING THE VARIOUS MOBYLETTE ENGINES

PART N°	DESCRIPTION AND FUNCTION	SUPPLIER	SUPPLIER'S PART N°
987	Truarc closing pliers	Var	420
988	Truarc opening pliers	Var	430
1117	Greaser wrench	Var	367
1179	Piston stroke limiter	Var	
1320	Forks busmes extractor	Var	360
1322	Tool for disassembling variator	Var	348
1323	Magnetic extractor	Var	344
1349	Piston pin adaptor	Var	396
15141	Clutch and variator drum extractor, 24 mm. dia. × 100 mm. lg.	Var	362
15142	Flywheel cam extractor, 26 mm. dia. × 100 mm. lg.	Var	359
15630	Spark plug wrench	Var	357
15746	Ignition timing feeler gauge	Var	239 bis
16733	Square tipped wrench for flywheel square head nut	Var	341
16753	Tool for taking off or mounting " Flexiblocs "	Var	361
17170	16 mm. dia. crankshaft dummy bearing	Var	
17630	Wrench for exhaust nut and variator	Var	342
	Pedal wrench	Var	18 bis
17635	Piston pin drift	Var	68 MOB
17644	Spoke wrench gauge 13	Var	51
17648	Spoke wrench gauge 16	Var	51
17649	Spoke wrench gauge 17	Var	51
no number	Tool for tightening the flywheel magneto drum	Var	

TOOLS FOR ALL TYPES OF MOBYLETTE CYCLE PART

Part N°	DESCRIPTION AND FUNCTION	SUPPLIER	SUPPLIER'S PART N°	Part N°	DESCRIPTION AND FUNCTION	SUPPLIER	SUPPLIER'S PART N°						
1.012	Técalémit grease gun	Técalémit	PZ		Steel discard head								
1.229	Hex. wrench for steering nut, handlebar, yokes	Var	335		Pointed chisel								
1.273	Bearing extractor for BG roller bearing (35 mm shell)	Var	142		End wrench, I.D. 10 mm, O.D. 12 mm ..	Facom	33						
1.320	Telescopic fork ring extractor	Var	360		End wrench, I.D. 19 mm, O.D. 21 mm ..	Facom	33						
1.352	Tool for insertion of bottom bracket bushings	Var	391		8 mm socket wrench	Facom	72						
1.354	Telescopic fork adjusting key	Var	397		9 mm socket wrench	Facom	72						
15.790	" Multipurpose " free wheel extractor ...	Var	01		11 mm socket wrench	Facom	72						
16.117	Pin wrench for pulley and BG roller	MB			12 mm socket wrench	Facom	72						
16.118	Measuring rod to check BG roller insertion	MB			16 mm socket wrench	Facom	72						
16.753	Engine hinge flexibloc mount fitter extractor	Var	361		Multiple pliers	Facom	180						
16.787	12 mm rear hub bearing extractor	MB			Combination pliers	Facom	187						
16.902	10 mm rear hub bearing extractor	MB			Round nose pliers	Facom	189						
16.992	32 mm across flats hex. wrench for fork spindle nut	Var	58/32		Scraper	Facom	231						
	Spark plug wrench				Chisel	Facom	252						
	Depth caliper gauge				Punch	Facom	256						
	Small screwdriver (4 mm wide blade)				Thickness gauge	Facom	804						
				(1) TOOLS NOT INCLUDED IN THIS BOOK									
				<table border="1" style="width: 100%;"> <tr> <td>Test bench "L'UNIVERSEL"</td> <td>Marollaud</td> </tr> <tr> <td>Electronic BERMASCOPE D 53 M</td> <td></td> </tr> <tr> <td>Pocket BERMASCOPE</td> <td></td> </tr> </table>				Test bench "L'UNIVERSEL"	Marollaud	Electronic BERMASCOPE D 53 M		Pocket BERMASCOPE	
Test bench "L'UNIVERSEL"	Marollaud												
Electronic BERMASCOPE D 53 M													
Pocket BERMASCOPE													
				(1) See special booklets.									

ENGINE STAND

(swiveling and swinging)

for engine disassembly and re-assembly

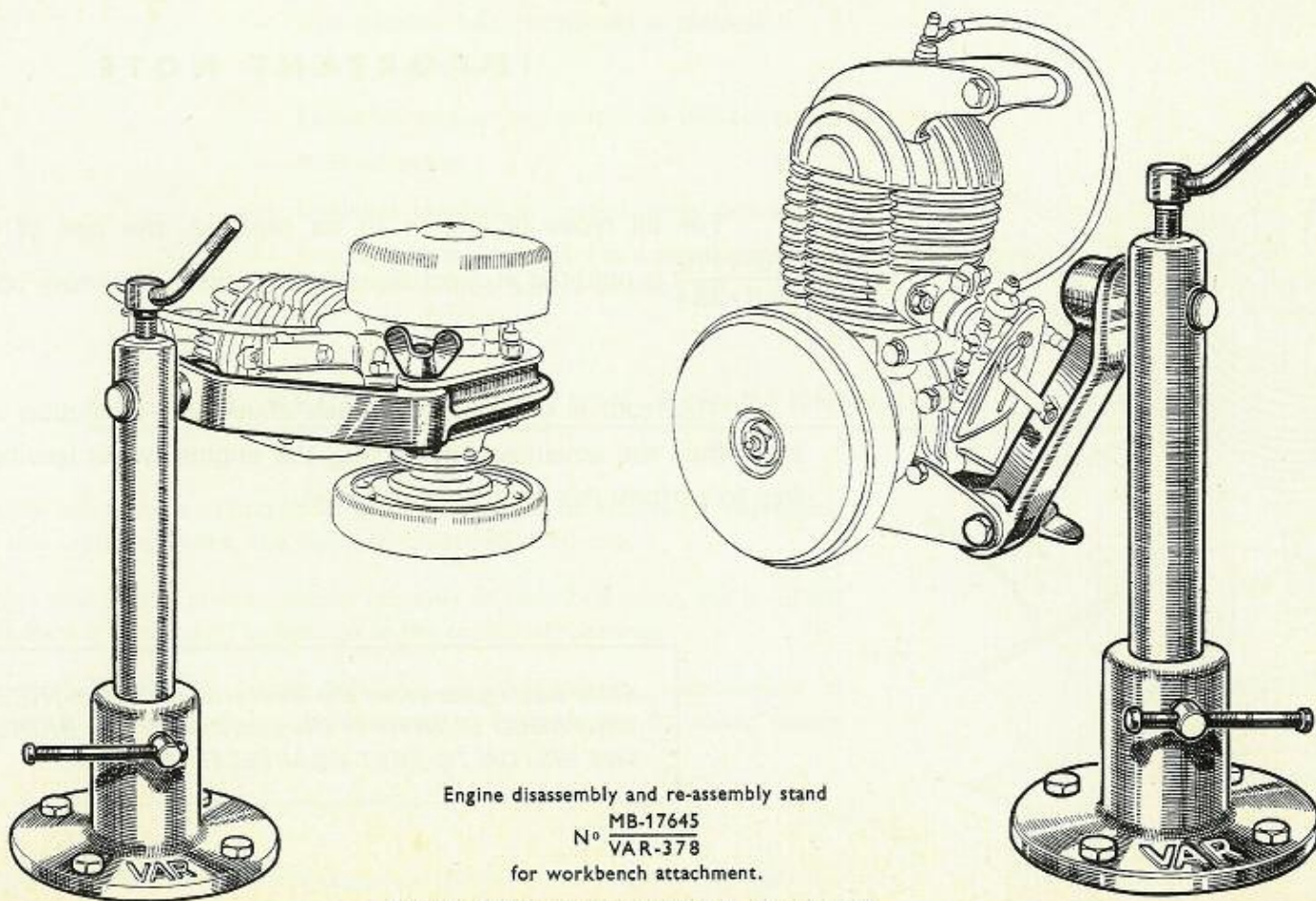

Engine disassembly and re-assembly stand

MB-17645

N° VAR-378

for workbench attachment.

For vise-held stand, see paragraph 1, operation 10,
page 26.

STROKE LIMITER

IMPORTANT NOTE

For all types of engine to be repaired, the use of stroke limiter **MB-1179** **VAR-394** is required in most disassembly and re-assembly operations.

This tool is designed to check crankshaft revolution at mid-stroke and offers the advantage of locking the engine whilst leaving both hands free to perform the operations required.

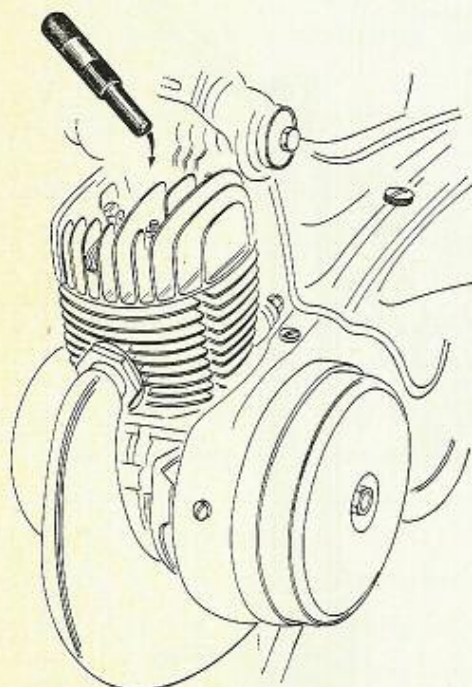

Stroke limiter N° 1179

*After having screwed the limiter over **THE WHOLE THREADED LENGTH** of the spark plug hole, **BRING THE PISTON TO REST AGAINST IT GENTLY.***



BELT DRIVE (Mobylette)

This drive system is quite reliable and very flexible. In normal condition it is fully satisfactory, and reasons to the contrary could only be the following:

- Non-genuine belt (frequently a problem)
- Insufficient tension.
- Excessive tension (on machines without a variator).
- Buckled pulley.
- Distorted, bumped or rugged pulley groove.
- Misalignment subsequent to a shock resulting in an offset engine or an out-of-true bottom bracket pin.

SPECIAL RECOMMENDATION CONCERNING BELT TENSION

- On reassembly, belt tension should be so adjusted that, when moderately depressing the driving side with the thumb, the deflection obtained is 10 mm.
- Do not forget that excess tension results not only in early belt wear, but in **LOSS OF POWER** for the engine and in damage to the crankshaft bearings.
- We recommend checking for correct belt and pulley alignment. Improvement of the alignment, if necessary, should be obtained by straightening the lower engine lugs.

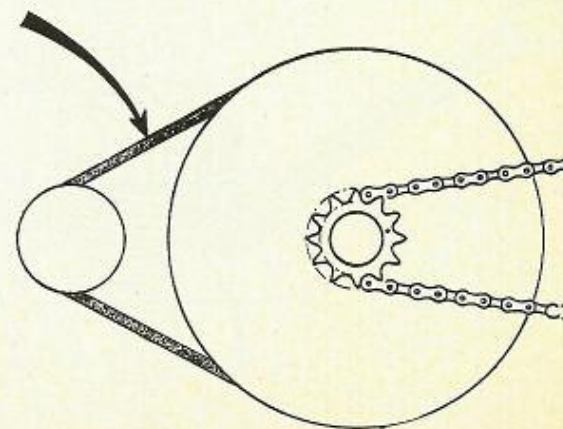

*Our belts have been the object of extensive testing and, especially for the Mobymatic, of specific development work. We therefore expressly recommend our dealers to fit **GENUINE BELTS EXCLUSIVELY***

REMOVING A FIXED ENGINE (OPERATION N° 1)

1st CASE

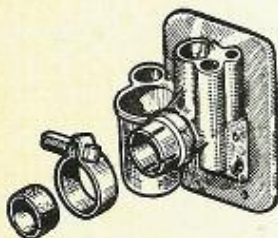

1st CASE

Loosen the collar bolt if the engine is equipped with an inlet pipe.

2nd CASE

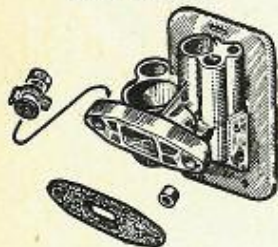

2nd CASE

Unscrew and remove the nuts and washers securing the carburettor to the cylinder (types 32 S and AV 41).

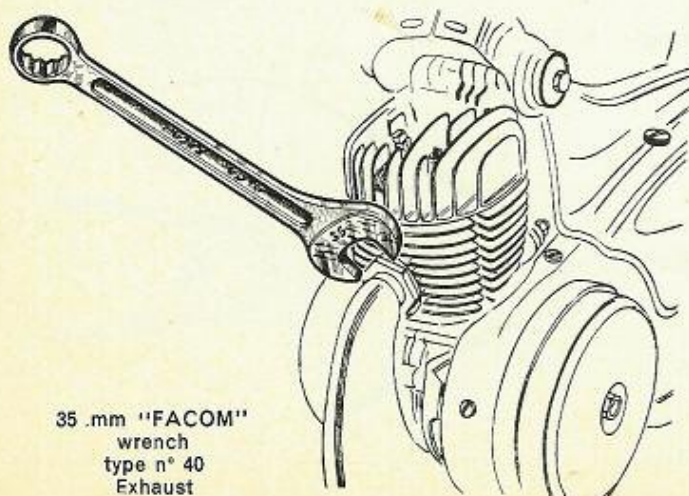

35 mm "FACOM"
wrench
type n° 40
Exhaust

- Remove both main chain guards.
- Remove the interference screen.
- Free the decompression control cable. To do this depress the spring with a screwdriver and extract the cable nipple secured under the retaining fork.
- Disconnect the lighting wire(s).
- Remove the carburettor (see the 2 cases shown alongside) (8-mm or 10-mm wrench).
- Loosen both engine crankcase which secure the belt guard. Remove the guard. (10-mm socket wrench).
- Disengage the exhaust angle pipe retaining nut FACOM 35-mm DUAL wrench, type No. 40).
- Remove the lower bolt securing the silencer lugs to the frame (12-mm socket wrench).
- Remove the exhaust assembly.
- Loosen and remove the nut on the upper attachment bolt (12-mm socket wrench).
- Remove the belt after pushing the engine to the rear.
- Support the engine and remove the upper bolt.
- The engine is fully detached from the frame.

NOTE - Machines 32 S - 65 - 76 - 85 are fitted with a detachable spacer at the upper attachment point. On machines 41-42-44 this spacer is braced to the frame.

TOOLS REQUIRED

Screwdriver
10 mm socket wrench
8 mm end wrench
12 mm socket wrench
35 mm Facom wrench

Average time required : 20 mn.

REFITTING A REPAIRED (FIXED) ENGINE (OPERATION N° 2)

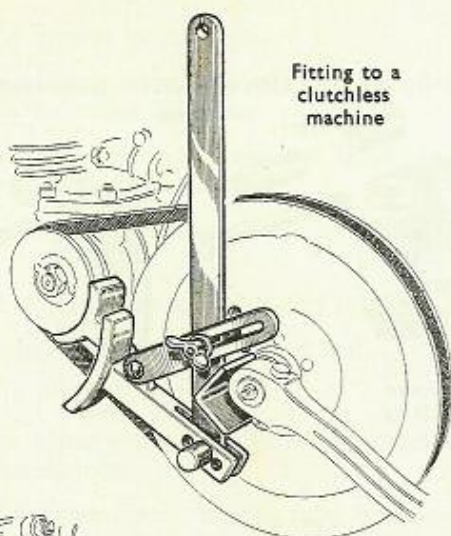

Belt stretcher N° 1351

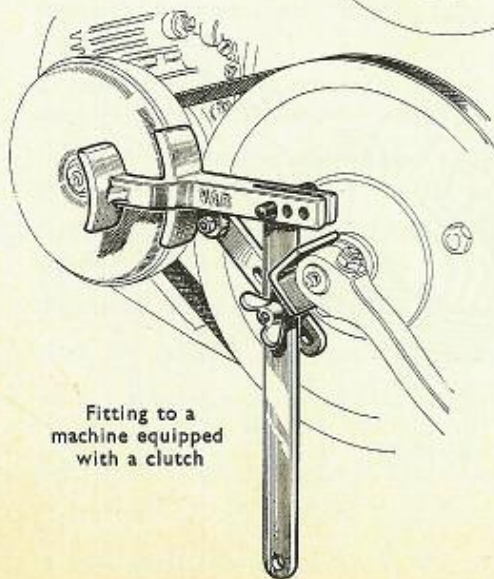

- Position the engine in the frame. Position the spacer. Insert the upper attachment bolt without locking it.
- Refit the exhaust assembly. Do not lock the exhaust angle pipe retaining nut on the cylinder.
- Insert the lower attachment bolt which also secures the clamp (or lugs) attaching the silencer. Do not omit the spacer which is located between the lower frame brackets.
- Fit the belt. **See NOTE 1.** Tension correctly (stretcher $\frac{\text{MB-1351}}{\text{VAR-343}}$)
- Lock the nuts on the upper and lower attachment bolts and on the exhaust.
- Reinstall the carburetor, driving fully home on the inlet pipe. Tighten the clamp bolt. **See NOTE 2.**
- Install the small belt guard. Lock both engine crankcase securing bolts.
- Connect the lighting wire(s).
- Install the decompression control cable, with its nipples in the retaining fork. Depress the spring with a screwdriver. Insert the sheath end socket into the spring eyelet.
- Refit both chain guards.
- Install the interference screen on the spark plug.

NOTE 1 - BELTS : See page 13, the special recommendation concerning belt tension.

NOTE 2 - Carburetors fitted to machine types 32 S and 41 are attached to the cylinder by a flange. It is recommended to check gasket condition and flatness of the flange. If the flange is distorted, it should be trued on a surface plate.

**TOOLS
REQUIRED**

Screwdriver
10 mm socket wrench
8 mm end wrench
12 mm socket wrench
35 mm Facom wrench
Stretcher n° 1351

Average time required : 35 mn.

REMOVING A HINGED VARIATOR ENGINE (OPERATION N° 3)

- Remove both main chain guards and the DIMOBY case.
- Remove the interference screen,
- Free the decompression control cable. To do this, depress the spring with a screwdriver, extract the cable nipple secured under the retaining fork.
- Disconnect the lighting wire(s) which are attached to the magnetic flywheel stator with clips.

In the case of an external coil ignition unit, disconnect the supply lead attached with clips to the coil.

- Remove the belt,
- Remove the carburetor by widely loosening the securing collar bolt.
- Unscrew the exhaust angle pipe retaining nut (FACOM 35 mm DUAL wrench, type N° 40).
- Unscrew the nuts on the bolts securing the silencer clamps to the lower engine lugs. Note : certain types have only one single clamp.
- Disassemble the lower attachment by removing the 6 mm nut retaining the engine lugs onto the silentblock which is integral with the tension springs.
- Remove the upper attachment nut.
- Support the engine and remove the bolt which acts as a hinge attachment.

VERY CAREFULLY NOTE SPACER POSITIONING AND GROUND WIRE.

On the AV 48 machine, grounding is achieved by means of a cup located on the upper attachment pin.

TOOLS REQUIRED

Screwdriver	35 mm FACOM wrench
8 mm end wrench	10 and 12 mm socket wrenches

Average time required : 25 mn.

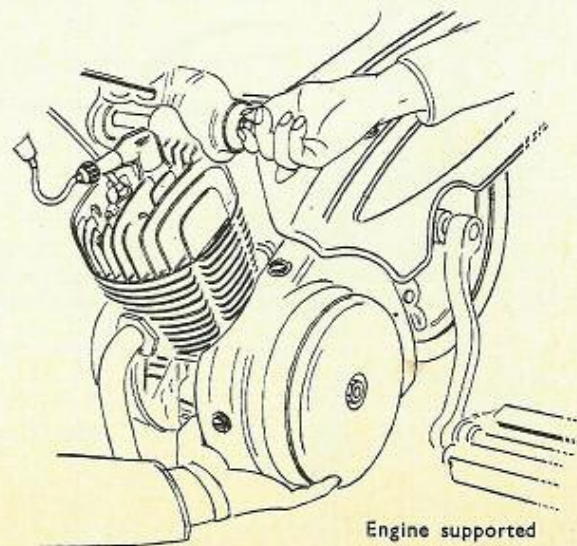
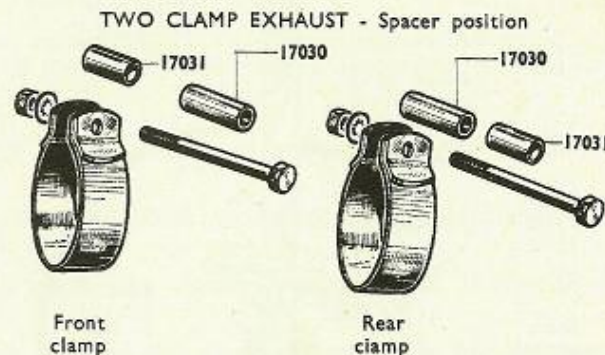

REFITTING A REPAIRED ENGINE (OPERATION N° 4) (HINGED VARIATOR ENGINE)

- Locate the engine in the frame.
- Insert the upper attachment bolt into the left-hand flexiblock and let it protrude by about 30 mm.
- Slide the small spacer and cylinder head upper boss, fitted with its body washers, over the bolt.
- Push the bolt in until it protrudes by about 3 mm from the cylinder head.
- Insert the ground wire eye ring and the long spacer.
- Fully engage the upper attachment bolt.
- Fit the nut without locking it.
- Secure the lower engine lugs to the silentblock which is built in with the loading springs.
- Reinstall the carburettor, driving fully home on the inlet pipe. Lock the clamp bolt.
- Connect the lighting wire(s) which is (are) attached to the magnetic magnet flywheel stator with clips.
- Connect the ignition supply lead to the external coil, the attachment being made with clips.
- Refit the exhaust assembly (fully screw the exhaust angle pipe retaining nut home, but do not lock it).
- Insert the silencer securing bolt(s).
- Lock the exhaust angle pipe nut and silencer bolt(s).
- Refit the belt ; lock the upper attachment nut **with the engine in mid-swing**.
- Reinstall the decompression control cable (see Operation No. 2)
- Attach both chain guards and variator case.
- Fit the interference screen on the spark plug.

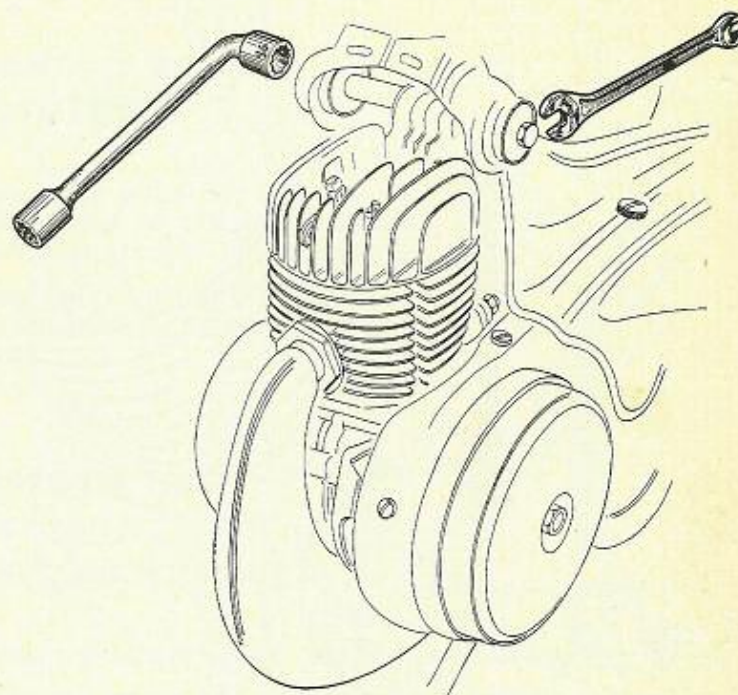

Locking the upper attachment nut
(engine in mid-swing position)

TOOLS REQUIRED

Screwdriver
10 mm socket wrench
8 mm and 12 mm end wrenches
12 mm and 14 mm socket wrenches
35 mm Facom wrench

Average time required : 35 mn

REMOVING A FLYWHEEL MAGNETO (OPERATION N° 5)

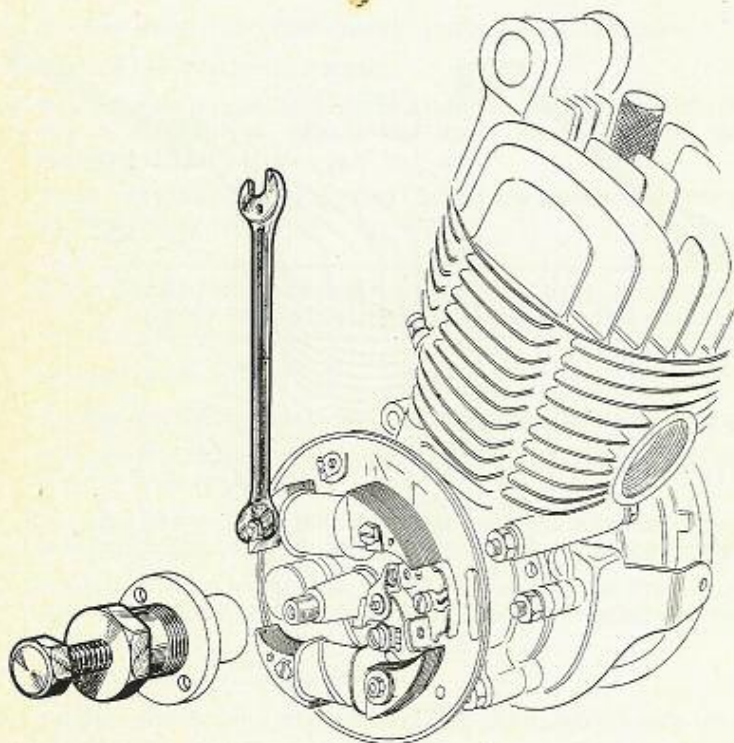

Flywheel magneto with wrench and extractor N° 15142

TOOLS REQUIRED

Spark-plug wrench
Stroke limiter MB-1179
Square tipped key MB-16733
Extractor MB-15142
8 mm wrench
17 mm socket wrench

Average time required : 5 mn.

- Remove the suppressor.
- Disconnect the lighting and external coil supply wires, attached with clips.
- Remove the spark plug, fit the stroke limiter.
- Rest piston on limiter and unscrew rotor nut. Wrench $\frac{\text{MB-16733}}{\text{VAR-341}}$ (watch thread hand).
- Remove the rotor.
- Fully engage the extractor $\frac{\text{MB-15142}}{\text{VAR-359}}$ onto the cam.
- Screw in the extractor center screw **smoothly** and pull the cam out.
- Remove the two 5 mm dia. \times 75 mm lg nuts securing the stator using an 8-mm wrench.
- Remove the stator assembly.

CAUTION

The flywheel magneto nut has a left-hand thread, except on the roller drive machine where it has a right-hand thread.

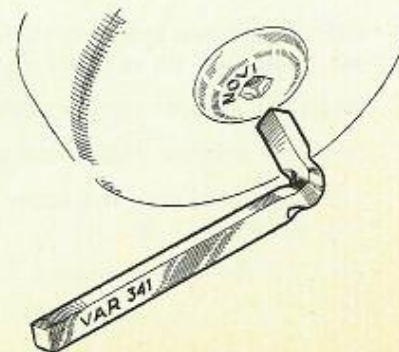

Square-tipped wrench N° 16733

REFITTING A FLYWHEEL MAGNETO (OPERATION N° 6)

ADJUSTING THE CONTACT BREAKER (a)

- Position the repaired stator on the two attachment studs. Drive fully home on crankcase centering pin. Position the high tension terminal or the external coil supply lead toward the carburettor.
- Insert the four cup washers.
- Using an 8-mm wrench, screw on the two 5-mm dia. x 75 mm lg nuts gradually until they are locked.

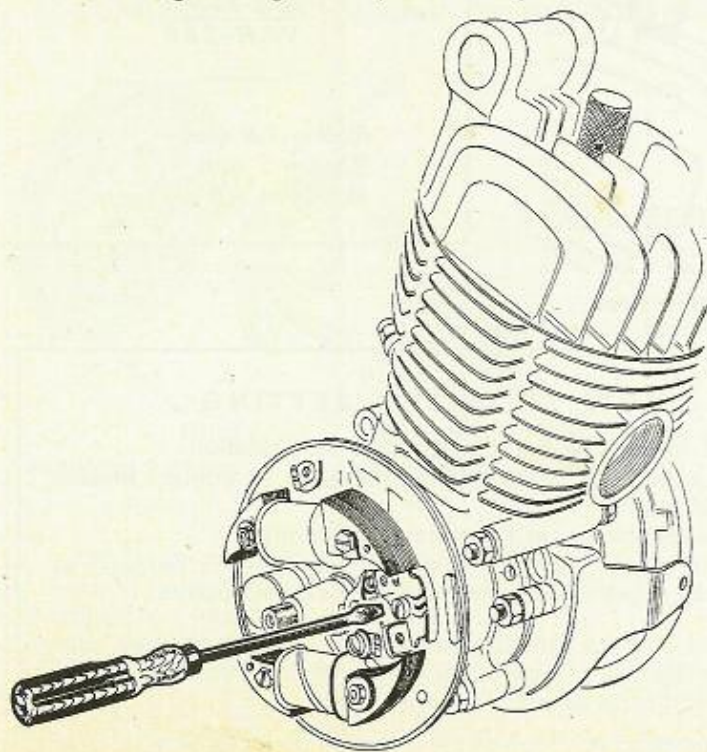

Contact breaker adjustment

(a) CONTACT BREAKER ADJUSTMENT

- Temporarily install the cam and revolve gently to obtain maximum gap between breaker contact points.
- Adjust the point gap, 0.35 mm min., 0.40 mm max. by means of a **feeler gauge**.

TO PERFORM THIS ADJUSTMENT, PROCEED AS FOLLOWS :

- Loosen the screw which retains the adjusting spring-fork.
- Pivot the contact breaker assembly to obtain the specified gap.
- Lock the adjusting screw.

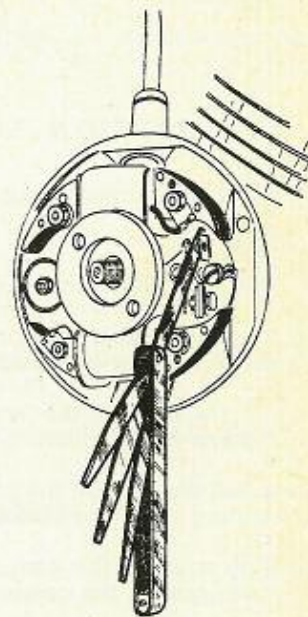

Adjusting the point gap

TOOLS REQUIRED

8-mm wrench
 Feeler gauge
 Screwdriver
 Adjustment gauge MB-15746
 Tube, I.D. 18 mm, O.D. 22 mm,
 150 mm lg
 Sparkplug socket wrench

Average time required : 5 minutes.

REFITTING A FLYWHEEL MAGNETO (continuation sheet N° 1) (OPERATION N° 6)
IGNITION TIMING (b)

(b) IGNITION TIMING

- Install adjustment gauge $\frac{\text{MB-15746}}{\text{VAR-239}}$ in place of the spark plug.
- Bring the piston to T.D.C.
- Align the upper section of the gauge body with the lower section of the specified colour.
- Slowly revolve the engine (in reverse rotation) until the color is fully hidden.
- Install the cam on the crankshaft, rotate the cam in the normal running direction (without driving the engine).
- Stop rotating the cam when a resistance is felt. (The cam starts hitting the coloron tappet).
- Insert a tube, I.D. 18 mm, O.D. 22 mm, lg 150 mm (from operation 11) within the cam threading.
- Knock lightly with a hammer in order to lock the cam partly on the crankshaft.
- **Check setting accuracy** →
- Remove the setting gauge. Install the stroke limiter.
- Install the rotor.
- Screw on and tighten the flywheel nut with the wrench $\frac{\text{MB-16733}}{\text{VAR-341}}$ or with a 5 m. kg torque wrench.
- Remove the stroke limiter and refit the spark plug.

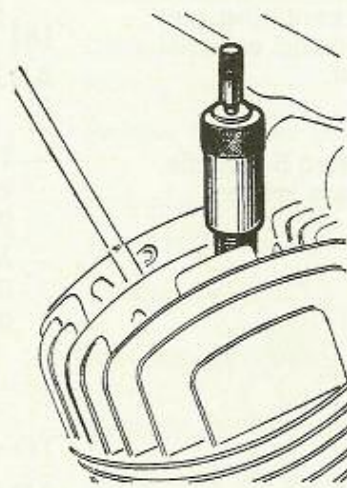

VAR adjustable gauge

COLOUR OF GAUGE

$\frac{\text{MB-15746}}{\text{VAR-239}}$

- Red = 1,5 mm
- Blue = 2 mm
- White = 2,8 or 3 mm

HOW TO CHECK SETTING

- Rotate the engine by 1/4 turn in reverse rotation.
- Insert a sheet of cigarette paper between the contact breaker contact points.
- Rotate the motor (in the normal direction).
- Exert a slight pull on the sheet. The latter is released as soon as a gap appears between the contact points.

This is correct ignition point, and at that precise moment the colour corresponding to the type of engine timed should become visible.

Average time required : 5 mn.

CENTERING THE ARMATURES ON THE FLYWHEEL MAGNETO MOUNTING PLATE

The flywheels on Mobylette 120 4 AC, series L and later models, including the present overlap plate flywheel, are so designed that components may be removed and refitted to the mounting plate without the cam having to be removed.

The removal of the flywheel unit and of the cam are dealt with in the preceding pages.

REMOVING THE H.T. ARMATURE (from the machine).

CONTACT BREAKER END : Fold back the lockwasher. Unscrew the hex head screw

CONDENSER END: Unscrew the NYLSTOP nut (8-mm wrench). Then unscrew the hollow bolt (9-mm wrench).

The primary lead being disconnected from the contact breaker, the armature is easily removed by rocking and rotating it around the crankcase stud.

Proceed likewise to remove the lighting coil (after unsoldering the output wire).

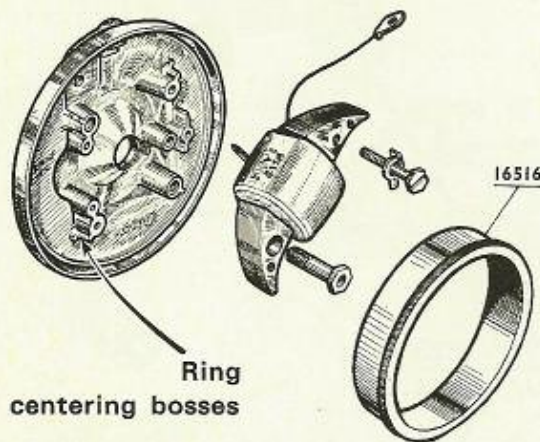

REFITTING THE H.T. ARMATURE (with centering ring 16516).

After locating the H.T. armature on the mounting plate, i.e. with the H.T. outlet facing the plate and directed towards the H.T. terminal, insert the crankcase stud in the hole of the armature horn, on the condenser end.

Position the armature primary lead towards the contact breaker. Slightly push the flexible H.T. armature outlet into the outlet hole of the H.T. terminal. Rotate the armature around the crankcase stud to align the hole in the horn on contact breaker end with the housing of the hex. head screw in the mounting plate. Insert the hex. head screw on the contact breaker side and the hollow bolt on the condenser side and screw, but leave ample play.

Locate the precision centering ring 16516 on the mounting plate bosses that have been specially machined. Rest the armature horns on the ring, and then tighten the screws. Remove the ring by slightly rotating, an easy matter as its edge is knurled. Fold the lockwasher ears against the hex. head screw.

Fit the NYLSTOP plate securing nut to the drilled bolt, where it acts as a lock nut. Replace the connection of the armature primary wire to the circuit breaker. The armature should no longer be interfered with, since its air gap is constant as a result of the assembly obtained with the precision RING. Proceed likewise to refit the lighting coil, but before performing the RING assembly the outlet lead must be soldered to the supply terminal lug.

**TOOLS
REQUIRED**
Ring 16516
7-8-9 mm wrenches

Average time required : 15 mn.

REMOVING A VARIATOR OR A DIMOBY CLUTCH OPERATIONS N° 7 and 8

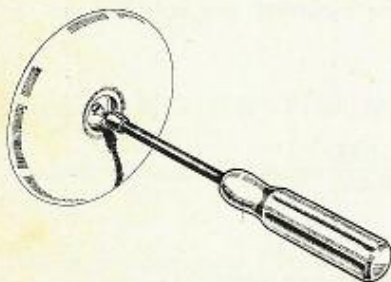

Grease nipple wrench n° 1117

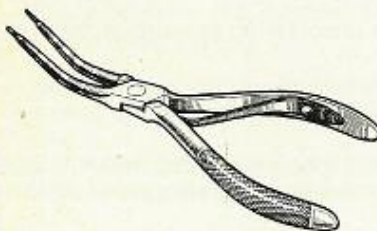

Closing pliers n° 987

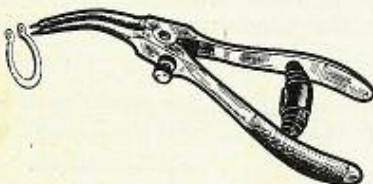

Opening pliers n° 988

- Remove the spark plug.
- Install the stroke limiter $\frac{\text{MB-1179}}{\text{VAR-394}}$ (see NOTE below)

- Unscrew the clutch retaining nut (14-mm socket wrench) (right-hand thread)
- Unscrew the 4 mm x 75 mm grease nipple. Nipple wrench $\frac{\text{MB-1117}}{\text{VAR-367}}$

- Screw extractor $\frac{\text{MB-15141}}{\text{VAR-362}}$ to the drum hub.
- Gradually tighten the center screw. The drum is easily pulled out.

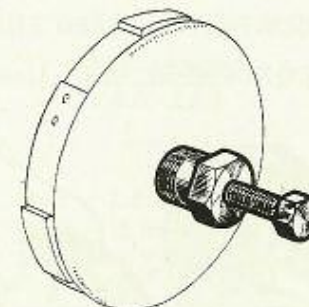

Drum extractor n° 15141

- Extract the woodruff key.
- Extract the first truarc by means of pliers $\frac{\text{MB-987}}{\text{VAR-420}}$

- Remove the stop washers. Use magnetic extractor $\frac{\text{MB-1323}}{\text{VAR-344}}$

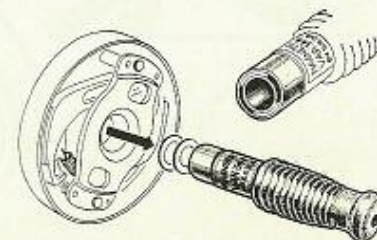

Magnetic extractor n° 1323

- Extract the second truarc by means of pliers $\frac{\text{MB-988}}{\text{VAR-430}}$
- Remove the complete assembly.

NOTE - See page 12 for instructions concerning the use of the limiter.

TOOLS REQUIRED :	
Spark plug wrench	Extractor 15141
Stroke limiter 1179	Truarc pliers 987
14-mm socket wrench	Extractor 1323
Grease nipple wrench 1117	Truarc pliers 988
17-mm socket wrench	

Average time required : 17 minutes.

REFITTING A VARIATOR OR A DIMOBY CLUTCH (OPERATION N° 9)

IMPORTANT

- Position accurately all bearing and securing components of the complete unit.
- Install needle cage N° 14712 inside the hub.
- Rest on the cage one of stop washers N° 14562 (a), 0.5 mm thick.
- Insert the smaller truarc, N° 14561.
- Place the second stop washer (b).
- Temporarily insert the larger truarc, N° 14563 (c) (pliers $\frac{MB-987}{VAR-420}$).
- Adjust side play (*See instructions below*).
- Install the larger truarc definitely.
- The assembly is ready for installation.

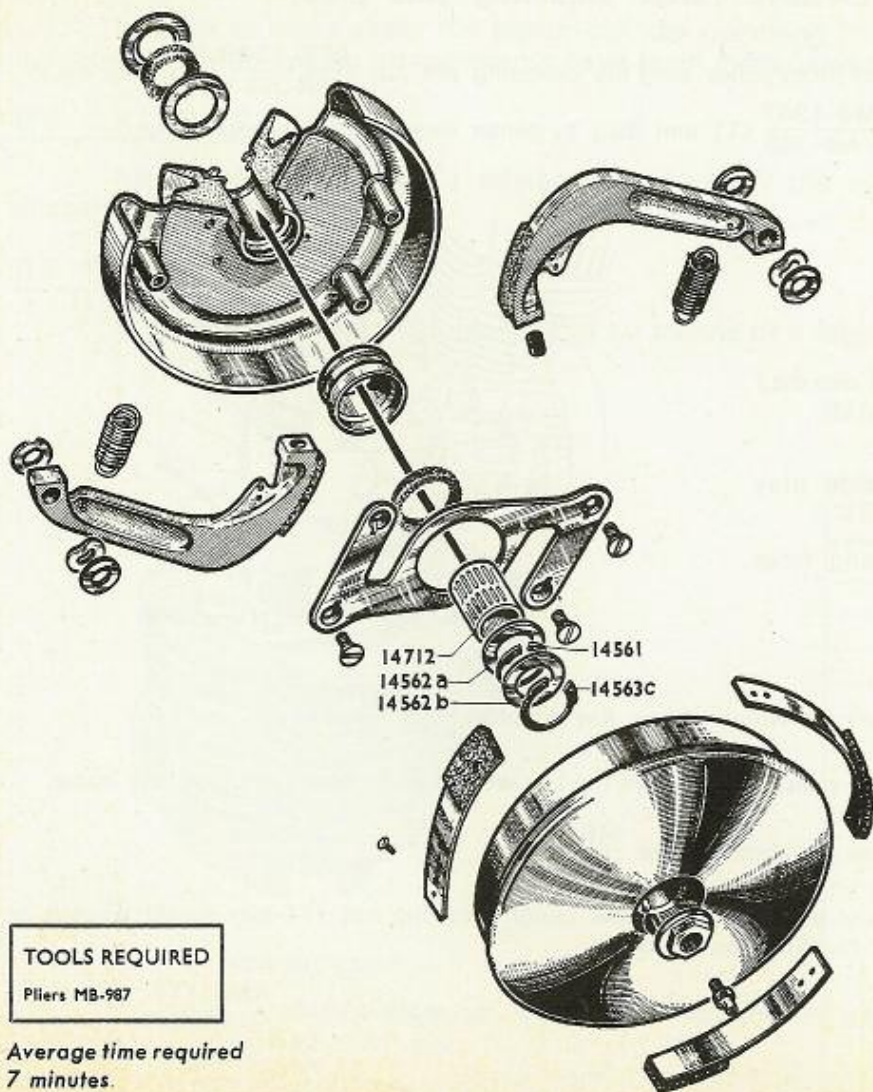

TOOLS REQUIRED

Pliers MB-987

Average time required
7 minutes.

INSTRUCTIONS FOR SIDE PLAY ADJUSTMENT

- Maximum permissible play is 0.1 mm.
- Place the special 0.1 mm thick spacers N° 14931 between stop washer (b) and larger truarc (c) N° 14563.
- when the larger truarc can no longer be accommodated behind the hub flange, remove one spacer and install the truarc definitely.

REFITTING A VARIATOR OR A DIMOBY CLUTCH (continued)

INSTALLING THE UNIT ON THE ENGINE (after adjusting side play)

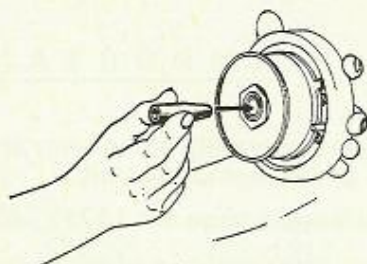

Centering pin on variator

- Insert (from pulley end) the centering pin No. $\frac{\text{MB-1348}}{\text{VAR-395 b}}$ (10 mm dia.) or $\frac{\text{MB-1347}}{\text{VAR-395}}$ (11 mm dia.) to center truarcs and washers correctly.

- Fit the drilled end of the pin to the crankshaft threaded end (10 or 11 mm dia.)
- Drive home squarely, the variator will seat in the final position.

The unit should rotate freely and without play if the side play adjustment has been achieved as advised.

- Rotate the crankshaft to T.D.C. so that the woodruff key housing faces upwards.

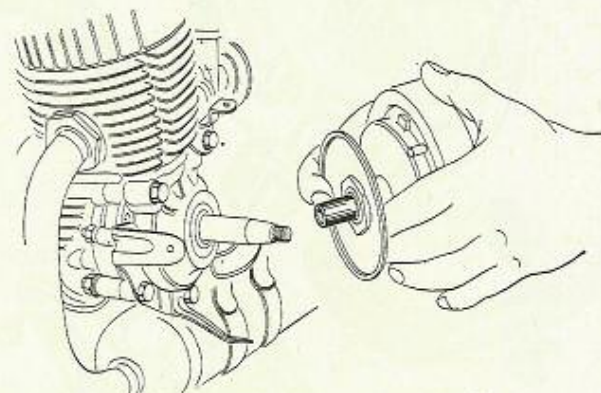

Fitting speed variator to crankshaft

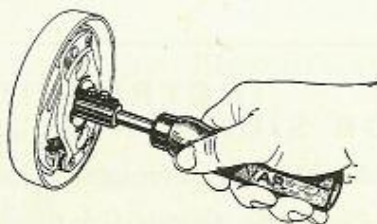

1321 - Installing woodruff key 1



1321 - Installing woodruff key 2

TOOLS REQUIRED

Centering pin MB-1348
or MB-1347
Key adaptor MB-1321
Stroke limiter MB-1179
14 mm socket wrench
Grease nipple wrench
MB-1117
Spark plug wrench

Average time
required : 10 mn.

- Install the woodruff key. Key adaptor $\frac{\text{MB-1321}}{\text{VAR-347}}$
- Install clutch drum : with the key well aligned, drive the drum fully home.
- Install the stroke limiter $\frac{\text{MB-1179}}{\text{VAR-394}}$
- Screw on and tighten the clutch retaining nut (14-mm socket wrench or 2.2. m kg torque wrench).
- Screw the small grease nipple to crankshaft. Wrench $\frac{\text{MB-1117}}{\text{VAR-367}}$
- Remove the limiter and fit the spark plug.

MARKING OF CYLINDERS AND PISTONS

In order to make easier the piston-cylinder matching in case the piston should have to be replaced during a repair by our Agents, the following arrangements have been made with our engine factory.

RE CYLINDERS

All cylinders will have a reference marked on the cylinder top : a letter corresponding to the size of the bore diameter (See table below).

RE PISTONS

All pistons delivered will be marked by means of a letter written with a pencil on the piston top.

MATCHING WILL BE EFFECTED WITH A CYLINDER AND A PISTON BEARING THE SAME LETTER.

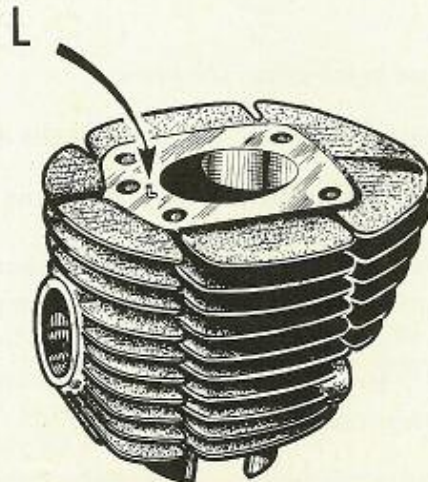

FOR INSTANCE :

For a cylinder, marked L, you should order a piston N° 16858.

REFERENCE	Ø PISTON	PART N°
A-A	38 - 935	18.307
A	-- - 940	16.853
B	-- - 945	18.308
C	-- - 950	16.854
D	-- - 955	18.309
E	-- - 960	16.855
F	-- - 965	18.310
G	-- - 970	16.856
H	-- - 975	18.311
J	-- - 980	16.857
K	-- - 985	18.312
L	-- - 990	16.858
M	-- - 995	18.313
N	39 - 000	14.819
O	-- - 005	18.314
P	-- - 010	16.859

COMPLETE DISASSEMBLY OF A MOBYLETTE ENGINE (OPÉRATION N° 10)

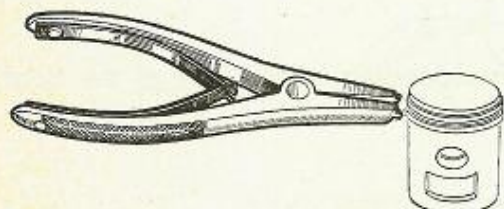

Piston ring pliers N° 1355

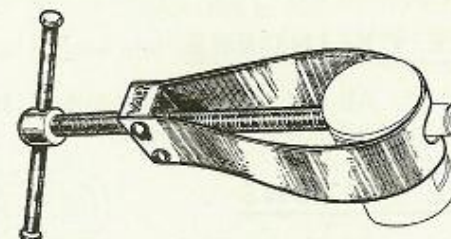

Piston pin drift pin N° 17635

- Insert a spacer between the engine lower securing brackets (or lugs) so that the engine may be firmly held in a vice, or use the engine stand $\frac{\text{MB-17645}}{\text{VAR-378}}$
- Remove the magnetic flywheel, the variator or the clutch (operations N° 5, 7, 8) **SEE NOTE BELOW.**
- Unscrew all 4 cylinder head nuts (10-mm socket wrench).
- Extract the washers (and on some types the upper attachment lugs).
- Remove the cylinder head and the cylinder.
- Remove the piston rings (pliers $\frac{\text{MB-1355}}{\text{VAR-261}}$).
- Remove the piston pin locks (round nose pliers) and drive out the pin (pin drift $\frac{\text{MB-17635}}{\text{VAR-68}}$).
- Mark the original assembly position, in case of re-use of the piston and cylinder.

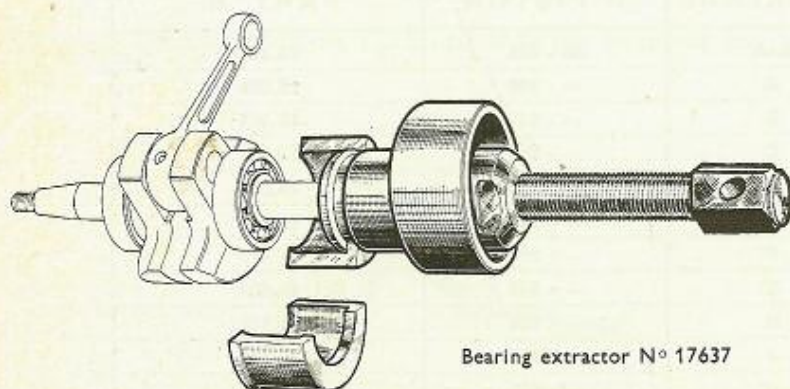

Bearing extractor N° 17637

- Loosen and remove the casing retaining screws and bolts (10-mm wrench).
- **On disassembly, note the arrangement of engine and guard lower attachment lugs.**
- Heat to about 100° C (Gazecom torch $\frac{\text{MB-1359}}{\text{VAR-350}}$) the crankcase end facing the flywheel around the outermost race of the crankshaft bearing. The half-case must drop off by its own.
- Proceed likewise for the remaining half-case.
- Extract both crankshaft bearings (extractor $\frac{\text{MB-17637}}{\text{VAR-142/42}}$).

TOOLS REQUIRED	
10-mm socket wrench	Gazecom torch MB-1359
Piston ring pliers MB-1355	Bearing extractor MB-17637
Round nose pliers	17-mm socket wrench
Pin drift MB-17635	Pin wrench MB-1360

Average time required : 25 minutes

NOTE - On clutchless machines (32 S - 41), unscrew the engine pulley lock nut (17-mm socket wrench, left-hand thread). Then unscrew the pulley (pin wrench N° 1360, right-hand thread).

COMPLETE ENGINE RE-ASSEMBLY (OPERATION N° 11)

SIDE PLAY ADJUSTMENT AND CRANKSHAFT ASSEMBLY IN THE CRANKCASES (a and b)

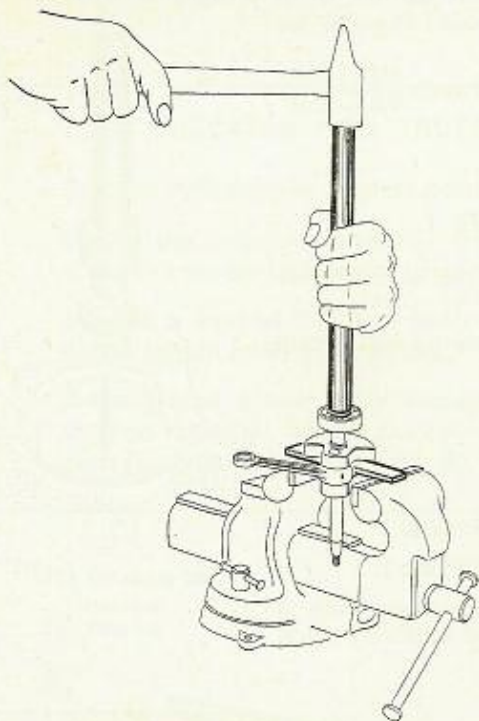

Fitting bearings to the crankshaft

(a) SIDE PLAY ADJUSTMENT (tentative assembly of crankshaft)

(Operation to be performed without gaskets).

- Fit the crankshaft tangs with dummy bearings (No. 16799, dia. 15 mm ; No. 17170, dia. 16 mm). These are available as spare parts.
- Install the crankshaft (with dummy bearings) in the crankcases.
- Fit the engine crankcase paper gasket. Assemble both half-cases (1 upper bolt and 1 upper screw).
- Clamp this assembly in a vice (over the lower bosses).
- Roughly assess the existing side play (depth caliper gauge).
- Remove the cases and place adjustment washers (distribute the washers between the crankshaft and bearings so as to balance the rod between casings).

Permissible play : max. 0.1 mm

IMPORTANT NOTE

16 mm I.D bearings are chamfered to one end to a large radius. This chamfer must face the crankshaft balance weight

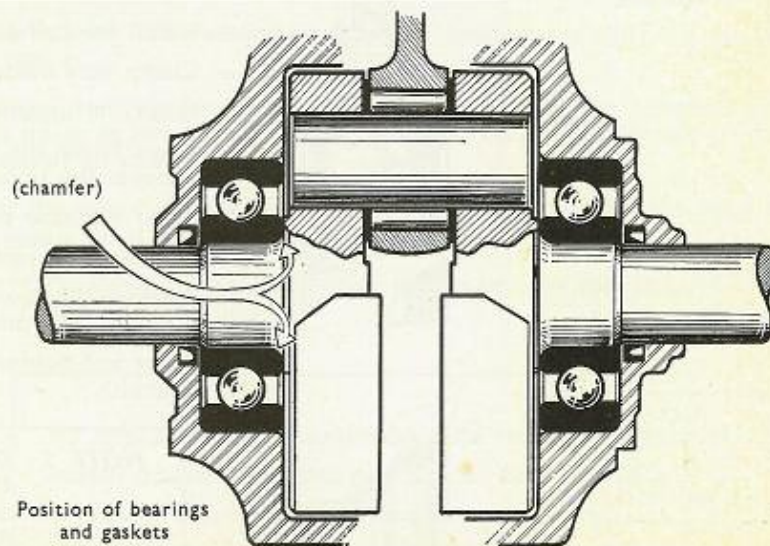

Position of bearings and gaskets

(b) FINAL CRANKSHAFT RE-ASSEMBLY

- Fit between both crankshaft balance weights a steel strip 120 × 30 × 7 mm.
- Install this assembly (without squeezing) in the jaws of a vice (75-mm spart).
- Install the washers assessed for that end of the crankshaft.
- Drive the bearing home tight against the washers (using a tube I.D. 18 mm, O.D. 22 mm, 150 mm lg).

CAREFULLY NOTE THE WAY THE BEARINGS ARE FITTED (SEE IMPORTANT NOTE ABOVE)

TOOLS
 REQUIRED : Dummy bearing $\frac{16799}{15}$ or $\frac{17170}{16}$ - Steel strip 120x30x7 - Tube I.D. 18 mm, O.D. 22 mm, 150 mm lg.

Average time required : 10 mn.

COMPLETE ENGINE RE-ASSEMBLY (continuation I) (OPERATION N°11)

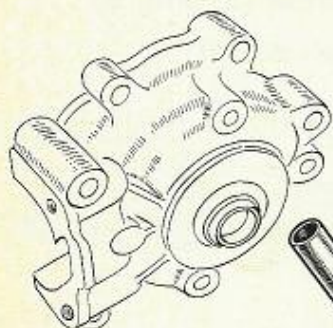

Gazecom torch
to heat case



**TOOLS
REQUIRED**
GAZECOM Torch
VAR - MB-1359
Seal guide MB-1353

Average time
required : 10 mn.

- Turn over the assembly clamped in the vice and proceed likewise for the other crankshaft end.
- Heat the magnetic flywheel half-casing to about 80° C (torch ^{MB-1359}VAR-350) around the bearing housing.

IMPORTANT.

- Place the oil seal (seal guide ^{MB-1353}VAR-399) **SEE NOTE 1.**
- Smear the crankshaft tang, the bearing and the oil seal with graphite grease.
- Fit the assembly in the half-case very rapidly, the bearing will locate itself correctly.
- Place the case gasket (oiled paper).
- Proceed likewise with the other half-case.
- Install the half-case, clutch end, on this assembly.
- Clamp very moderately the lower casing bosses in the vise.
- Insert the upper screw and upper bolt (without tightening.)
- Align finely the cylinder-to-case junction line by knocking with a hammer the upper part of a cylinder-to-cylinder head assembly stud.
- Flush the case paper gasket with a scraper.
- Tighten the upper bolt and screw. **SEE NOTE 2.**
- Position the lower engine attachment brackets and the dual lug of the DIMOBY protective case (variator machines).
- Insert and tighten the bolts (nuts facing magnetic and, 10-mm socket wrench).

NOTE 2 - On variator machines, before tightening the upper screw, locate the cylinder in order to position the upper attachment lug of the DIMOBY case. The catch on this lug must rest against the lower cylinder fin.

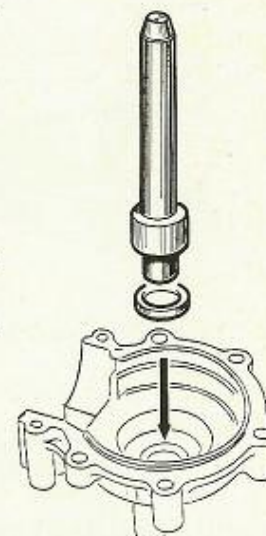

Seal guide N° 1353.
to insert
oil seals

NOTE 1

Seals must be placed with their lips facing outwards so that no dust may be admitted during decompression.

COMPLETE ENGINE RE-ASSEMBLY (continuation 2) (OPERATION N° 11)
FITTING THE PISTON IN THE CYLINDER AND STRAIGHTENING A ROD (c and d)

CHECKING ROD TRUENESS

- Position cylinder over ringless piston.
- Secure the cylinder diagonally with two spacers and two cylinder head nuts. Bring piston to T.D.C.
- Slide in a tapered 0.07 mm feeler gauge between piston (at pin hole) and cylinder.
- If the gauge enters freely through one end not through the other, remove the cylinder and proceed with straightening. Figure page 30.

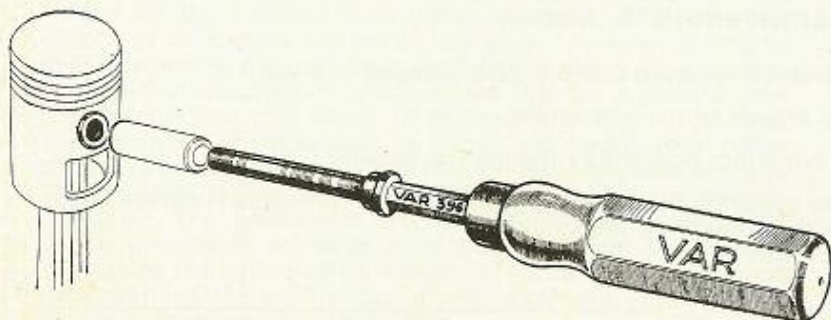

Piston pin assembler N° 1349

**TOOLS
 REQUIRED**
 Piston pin assembler
 N° 1349

(c) FITTING THE PISTON IN THE CYLINDER

- Place a spacer between the lower attachment brackets (or lugs) in order to clamp the crankcase firmly in a vice.
- Set the piston on the rod (needle cage assembled).
- Insert an old piston pin (O.D. 12.9 mm).
- Heat to about 100° C the piston top (torch $\frac{\text{MB-1359}}{\text{VAR-350}}$).
- Fit the final piston pin on pin assembler $\frac{\text{MB-1349}}{\text{VAR-396}}$
- Insert the assembler tip into the old pin.
- Drive fully in. The assembler stop will position correctly the pin in the piston.
- Position the cylinder on the hot ringless piston; the cylinder will slide down as temperature evens out. This operation prevents piston distortion on cooling.
- After the piston-cylinder assembly has cooled off, rotate the engine. **to make sure the rod requires no straightening.**
- See "Checking rod trueness" on this page, and rod straightening next page under (d).

By applying the disassembly and re-assembly methods we describe, no rod can be distorted or bent. Such anomaly could only occur in case the piston is disassembled by hammering.

COMPLETE ENGINE RE-ASSEMBLY (continuation 3) (OPERATION N°11)

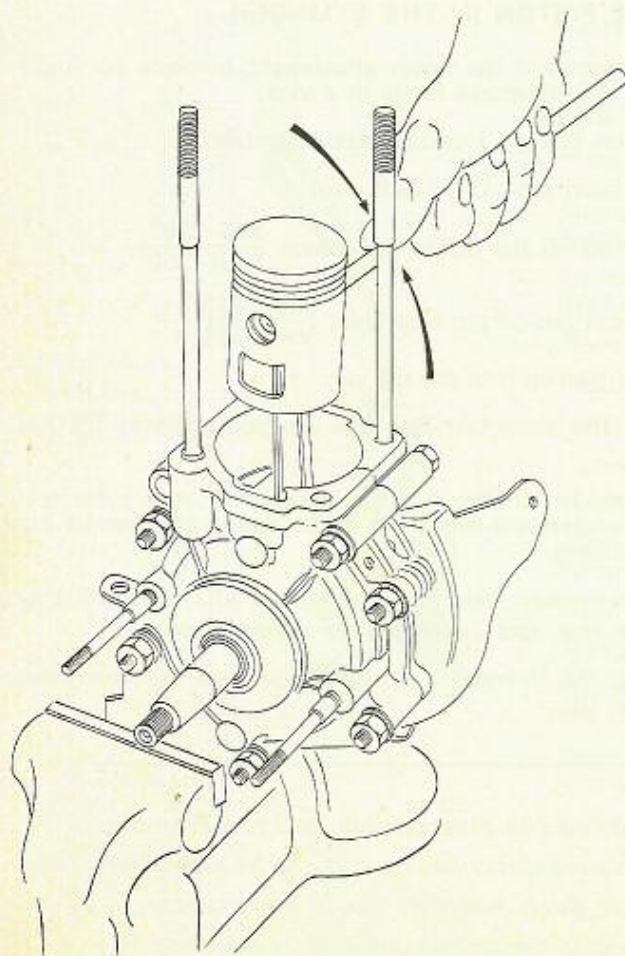

Straightening a rod

- Remove the cylinder.
- Install new circlips (round nose pliers).
- Install the piston rings (pliers $\frac{MB-1355}{VAR-261}$)
- Set cylinder gasket (smeared with oil on both sides).
- Reset cylinder on its four studs (slide down gradually).
- Set cylinder head gasket.
- Install the cylinder head after having cleaned it perfectly. Install the upper attachment lugs, if necessary.
- Place washers and cylinder head nuts (tighten gradually and diagonally).
- Tighten without excess (10-mm socket wrench or 1.2 m. kg torque wrench).
- Install the variator or the clutch (Operation No. 9).
- Install the flywheel magneto (Operation No. 6).

(d) STRAIGHTENING A ROD

- The cylinder is removed and the case clamped in a vise.
- Insert a broach in the piston pin.
- Slowly bring into position by forcing the broach.
- Check as specified on preceding page, and straighten again until the piston is correctly centered in the cylinder.

TOOLS REQUIRED

Dummy bearing 16799 or 17170	Seal guide MB-1353
15 16	10 mm socket wrench
Depth caliper gauge	Piston pin assembler MB-1349
Steel scrip 120x30x7 mm	Feeler gauge
Tube I.D. 18 mm, OD 22 mm,	Round nose pliers
150 mm lg.	Piston ring pliers MB-1355
Gazecom torch MB-1359	Scraper

Average time required : 50 mn.

DESCRIPTION AND OPERATION OF THE "MOBYMATIC" VARIATOR

DESCRIPTION

— As is the case for all Mobylettes, the Mobymatic has a primary rubber belt drive which provides the well-known smoothness and flexibility, and a secondary chain drive.

— But the Mobymatic primary drive is a special one. The driving pulley locked on the engine is a special collapsible one, whose cheek spacing is variable under the influence of centrifugally-moved balls pushing on the cheek side which is opposite the belt. As the cheeks spread apart or close in, the winding diameter of the V-belt varies, and this in turn modifies the reduction ratio from 18.7: 1 to 11.8: 1. The engine tilts around its upper attachment axis. A spring-loaded device tends to push it forward, thus ensuring belt tension.

OPERATION

— On starting, the engine revolves slowly as soon as it engages. The springs which push the engine forward compel the belt to rest on the smallest drive-pulley diameter. The reduction ratio is at its highest, we are in low gear. As soon as engine speed increases, the balls push the movable cheek, thus decreasing the reduction ratio, which means that for a given engine rpm the machine rolls faster. If the mobylette is on a flat road, the belt goes on increasing to larger and larger drive pulley diameters until top speed is reached. If the Mobylette engages an up-grade, the speed of both machine and engine tend to decrease. The balls exert less push on the movable cheek which then tends to move away from the fixed one thereby decreasing the belt winding diameter. As this change of speed is continuous, the modification in reduction ratio, although fast, occurs gradually without any jerks.

Incidentally, the Mobymatic responds to changing road as well as to cruise conditions.

Embrayage centrifuge = centrifugal clutch.

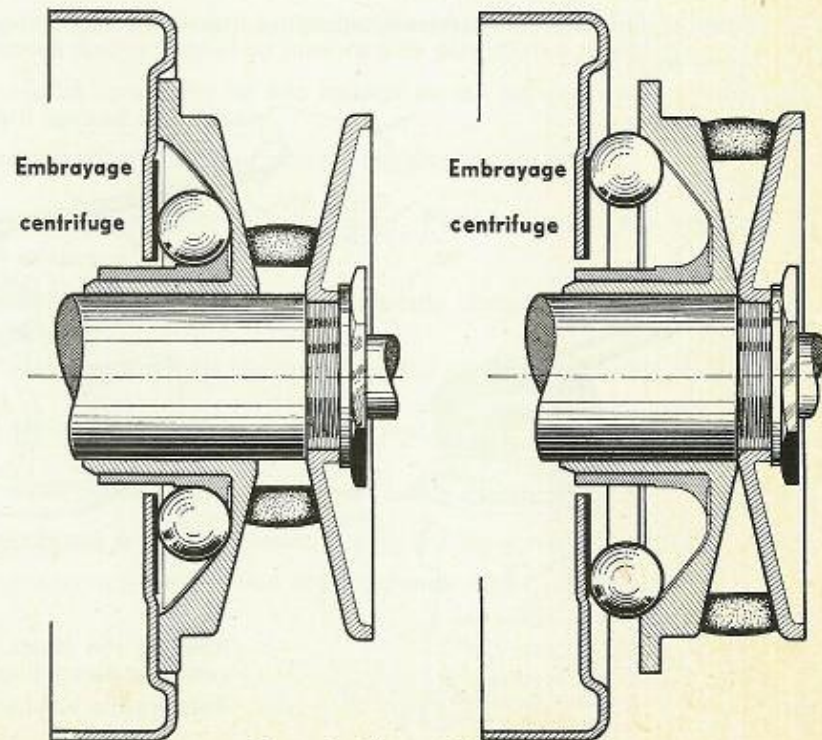

Operating diagram of the variator

COMPLETE DISASSEMBLY OF A VARIATOR (OPERATION N° 12)

(MODEL WITH SCREWED FIXED CHEEK)

ALL MOBYMATIC TYPES :

Belt : 18x8 : 89 - SP 50 - SP 50 R (as from the start) Variator unit number : 16840

Belt : 14x7 : 88 - 68 - 79 - 48 (as from June 1963) Variator unit number : 17796

- Install the speed variator on dismantling the tool MB-1322
VAR-348
- Unscrew the lock nut 25 mm dia. 100 mm lg, left-hand thread (35-mm FACOM wrench).
- Unscrew fixed cheek (right-hand thread) with the clamp MB-1350
VAR-398
- Remove the stop washer and collect the movable cheek, ball cage and balls (the stop washer is exists only on 18-mm belt variators).
- Loosen and remove the 4 screws retaining the drum to the hub. Screw-driver MB-1356
VAR-298 (figure page 34).

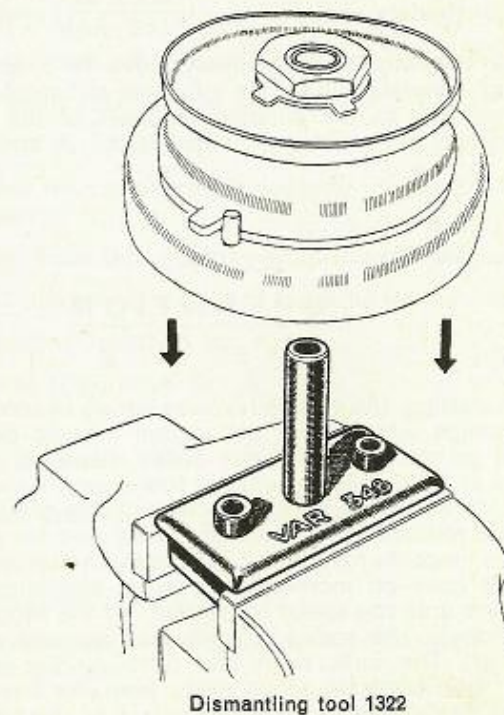
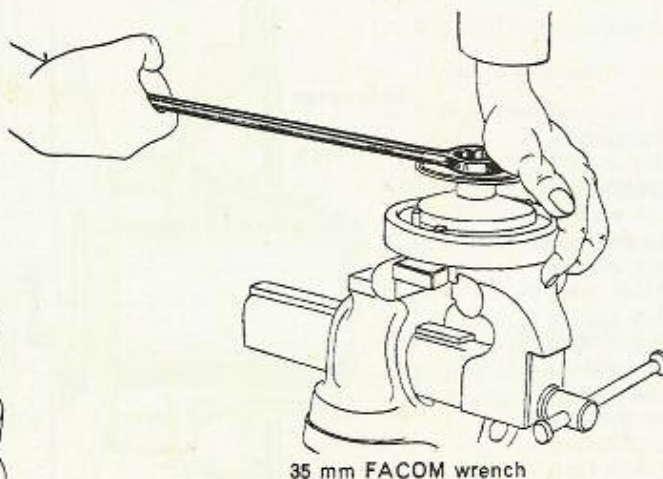
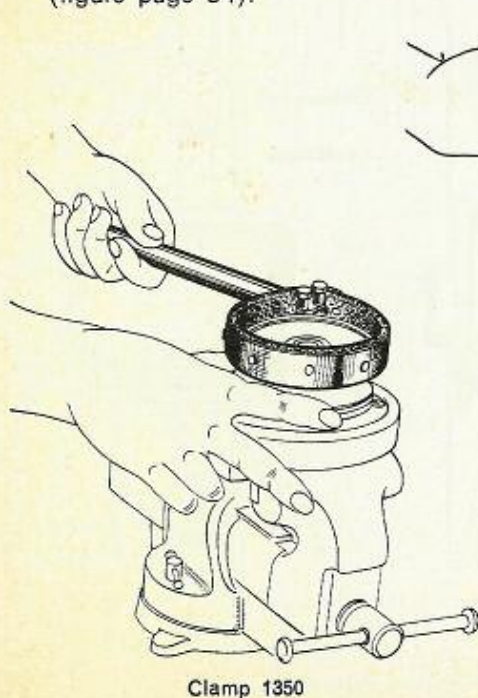

- Remove the drum. Extract the clutch shoes by sliding them vertically along their pivot.
- Remove the washers. The hub is completely stripped.

TOOLS REQUIRED

Dismantling tool MB-1322
35 mm FACOM wrench
Clamp MB-1350
Screwdriver MB-1356

Average time
required : 10 mn.



RE-ASSEMBLING A VARIATOR

(OPERATION N° 13)

(MODEL WITH SCREWED FIXED CHEEK)

ALL MOBYMATIC TYPES :

Belt : 18x8 : 89 - SP 50 - SP 50 R (as from the start)

Variator unit number : 16840

Belt : 14x7 : 88 - 68 - 79 - 48 (as from June 1963)

Variator unit number : 17796

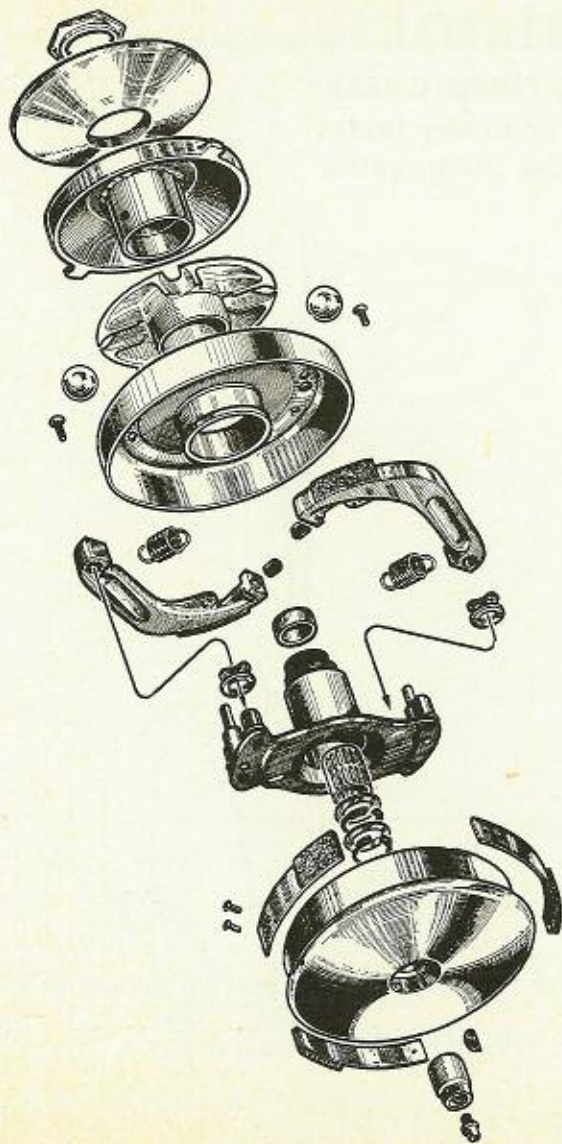

Screwed cheek variator

- Install the clutch hub on the dismantling tool MB-1322
VAR-348
- Place on both pillars, furthest from the movable cheek stop, a 10-mm dia. $\times 15 \times 2$ mm plain washer and a spring washer to prevent side play on the flyweights.
- Install the flyweights connected by two springs on the pillars ; when **fully fitted in, they should spread out freely.**
- Secure the clutch bell with all four screws (tighten gradually).
- Tighten all four screws (screwdriver MB-1356
VAR-298). **Punch lock in the notch provided to that effect.**
- Take the movable cheek, the hub turned upwards. Install the ball cage with the balls in their recesses.
- Extract clutch hub from the VAR tool and fit in the complete movable cheek.
- Turn over and replace the above assembly on tool MB-1322
VAR-348. Install a stop washer.
- Screw on the fixed cheek (right-hand thread using Clamp MB-1350
VAR-398).
- Screw on the lock nut (left-hand thread,) using the 35-mm dual wrench.
- The variator unit can now be installed in accordance with Operation No. 9.

TOOLS REQUIRED

Dismantling tool MB-1344
Screwdriver MB-1356
Punch
35 mm FACOM wrench
Clamp MB-1350

Average time required : 20 mn.

COMPLETE DISASSEMBLY OF A VARIATOR (OPERATION N° 14)

VARIATOR N° 16.704 (MODEL WITH UNTHREADED FIXED CHEEK)

"Mobymatic" models (belt : 14 x 7 - AV 88 - 68 - 79 - 48, up to May 1963)

- Install speed variator on the dismantling tool MB-1322 VAR-348 (Fig. on page 32) :
- Fold the retaining nut : lock N° 15186 using a chisel.
- Unscrew the nut 27 mm dia., 100 mm lg, **right-hand** (35 mm FACOM wrench). Fig. on page 32.
- Apply lever action to drive off the fixed cheek.
- Retrieve the movable cheek, the ball cage and the balls.

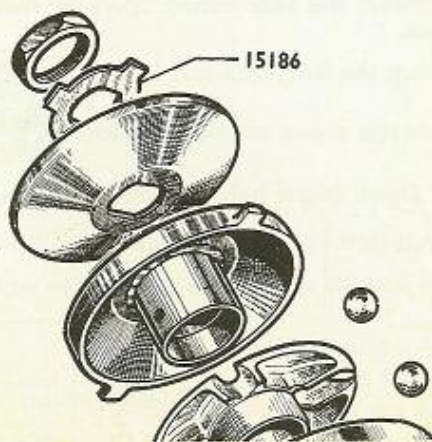

Variator part

**TOOLS
REQUIRED :**
Dismantling tool
MB-1322
Chisel
35 mm Facom wrench
Screwdriver MB-1356

Average time
required : 10 mn.

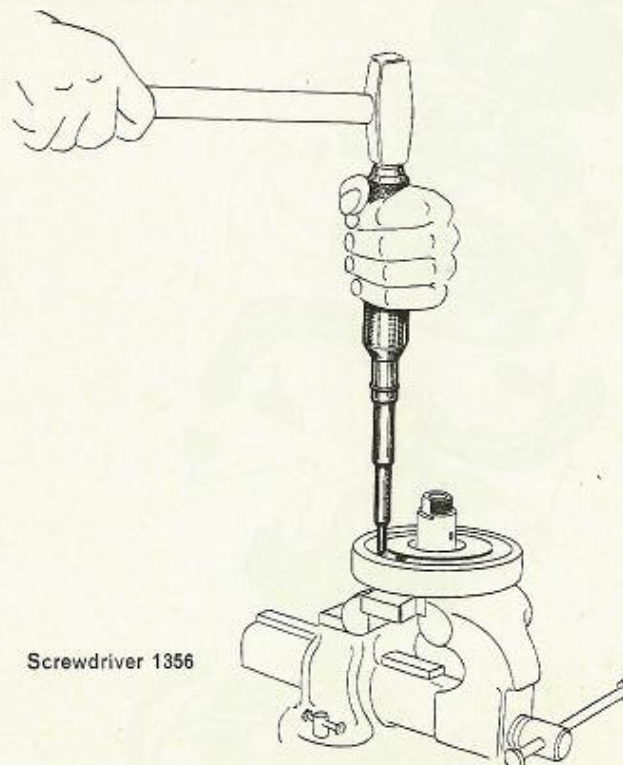

Screwdriver 1356

- Loosen and remove the four screws securing the bell to the hub. Screwdriver MB-1356 VAR-298
- Remove the bell. Extract the flyweights by sliding them vertically along their pivot.
- Extract the washers. The hub is completely stripped.

RE-ASSEMBLING A VARIATOR (OPERATION N° 15) (MODEL WITH UNSCREWED FIXED CHEEK)

MOBYMATIC MODELS *(belt : 14x7 - AV 88 - 68 - 79 - 48, up to May 1963)*

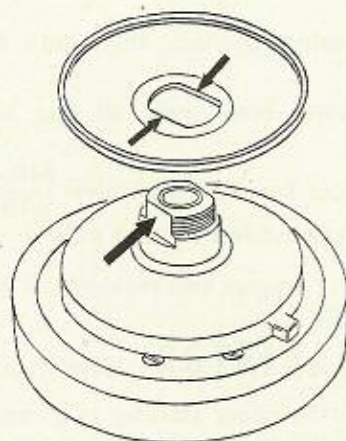

- Proceed as for operation N° 13 except for assembling the fixed cheek which fits both flats on the clutch hub.
- Place the lock washer, then the nut (right-hand thread).
- Tighten the nut (35-mm FACOM wrench).
- Lock the nut, with the tab folded up along one of the nut flats.
- The variator can now be installed in accordance with operation N° 9.

IMPORTANT

*This must be a very tight fit, i.e.
 WITHOUT PLAY.*

TOOLS REQUIRED

Dismantling tool MB-1322
 Screwdriver MB-1356
 35-mm FACOM wrench

Average time required : 20 minutes.

COMPLETE DISASSEMBLY OF A "DIMOBY" CLUTCH

OPERATION N° 16

- Clamp the pulley integral with the clutch in a vise fitted with copper jaws.
- Loosen and remove (screwdriver **MB-1356** / **VAR-298**) all four screws securing the block brace to the pillars.
- Remove the block brace. Remove the washers.
- Extract the flyweights by sliding them vertically along their pivot. **CAUTION**
- Extract the flyweight lower stop washers.

CAUTION

On disassembly, carefully mark the flyweight position. The flyweights are fitted in reverse direction in the clutches of roller-driven machines.

Average time required : 10 mn.

RE-ASSEMBLY A "DIMOBY" CLUTCH

OPERATION N° 17

- Place an 8-mm I.D. flat washer on each pillar (flyweight pivot).
- Fit both flyweights (connected with two springs) on the pillars.
- Place both spring washers, then both flat washers on the flyweights.
- Secure the block brace with all four screws (tighten gradually).
- Tighten the four screws (screwdriver **MB-1356** / **VAR-298**). **Punch lock in the notch provided to that effect.**

Average time required : 15 mn.

ADJUSTING A "DIMOBY" CLUTCH WITHOUT VARIATOR

OPERATION N° 18

- The flyweights are drilled with four 2-mm holes for hooking both return springs. To allow starting at a lower speed, it is possible to hook the springs in the holes nearest to each other, in order to decrease spring tension.

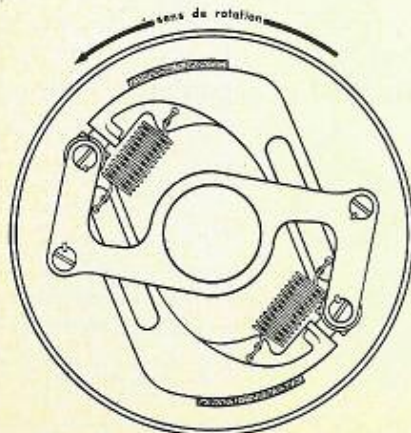

Standart clutch : view of the flyweights

NOTE - On a Dimoby fitted with a variator, this adjustment is not required on account of the very high reduction ratio. However, the principle remains applicable.

TOOLS REQUIRED
Screwdriver MB-1356
Punch

Average time required : 25 mn.
(If several positions have to be tested).



BG clutch : view of the flyweights

C Y C L E
S E C T I O N



SKETCH OF A REPAIR BENCH

This sketch may be used to build a repair bench

This bench is fitted with two attachment systems :

- 1) One system, with a flanged tube, for operations on upside-down machine.
- 2) Another system, with a securing clamp, to hold the front or rear wheel whilst the machine rests on its own stand.

Tube I. D. 26 mm, O. D. 34 mm, 177 mm lg, welded lengthwise to 3 mm thick plate.

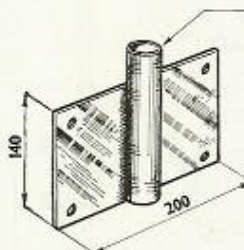

2 mm thick plate, 2 m lg, 0.55 m width, secured with 34 countersunk screws, 5x25.

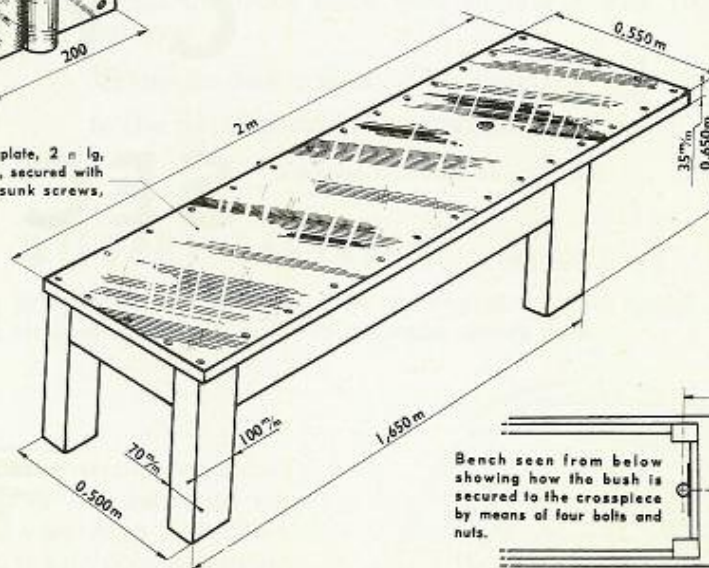

Bench seen from below showing how the bush is secured to the crosspiece by means of four bolts and nuts.

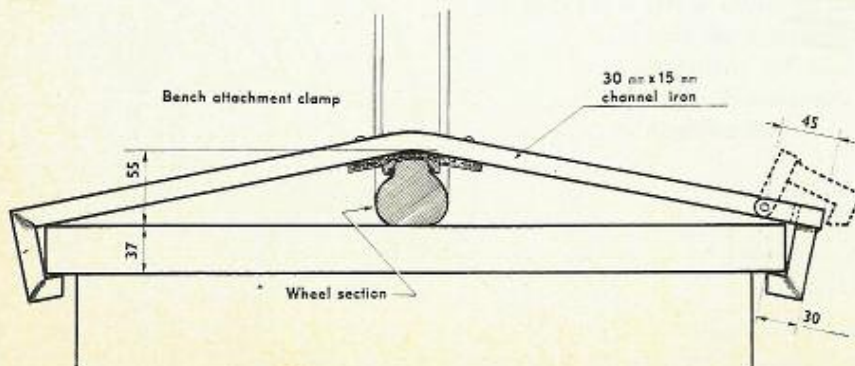
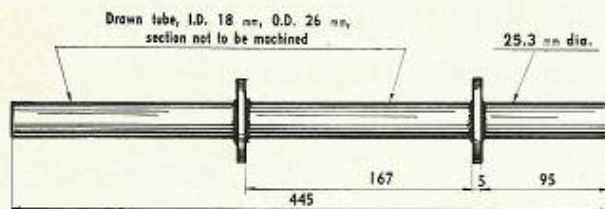

REPAIRING A RIGID FORK OR REPLACING A STEERING UNIT (OPERATION N° 19)

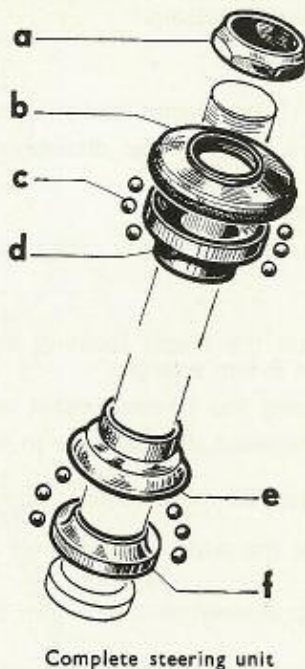

TOOLS REQUIRED

Screwdriver
Multiple pliers
16 mm socket wrench
12 mm socket wrench
8 mm socket wrench
10 mm socket wrench
32 mm wrench MB-1229

Average time required : 1 hour 30 mn.
(together with re-assembly by operating in reverse sequence)

- Drain the tank.
- Remove the saddle and seat post (12-mm socket wrench).
- Turn the machine upside down and rest it on a stand engaging the seat tube. (see sketch on page 38).
- Remove the front wheel (16-mm socket wrench).
- Disconnect the lighting wires inside the head lamp.
- Remove the mudguard and the front brake (8 and 10-mm socket wrenches).
- Remove the handlebar and control grips (12-mm socket wrench).
- Unscrew and remove the 8-flat upper lock nut (a) (32-mm wrench MB-1229 VAR-335).
- Pull out the notched front brake bracket.
- Unscrew the top bearing cup (b). Retain the balls (multiple pliers).
- Pull out the fork (rotate slightly to leave the balls in the lower cup).
- Collect the steering balls (c).
- Extract the bottom bearing cup (e) and upper cone (d).
- Remove the bottom cone (f) secured to the fork tube.
- Proceed in reverse order for re-assembly.

REPAIRING OR REPLACING TELESCOPIC FORKS (OPERATION N° 20)

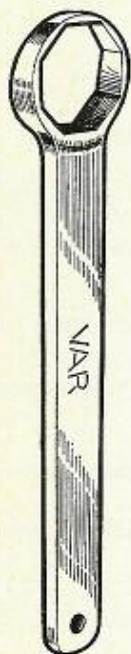

Wrench MB 1229
for upper lock screw

- TOOLS REQUIRED**
- 12 mm socket wrench
 - 16 mm socket wrench
 - Screwdriver
 - 10 mm socket wrench
 - Multiple pliers
 - 14 mm socket wrench
 - 32 mm wrench MB-16992
 - 8 mm flat wrench
 - 32 mm wrench MB-1229
 - Chisel

Average time
required : 2 hours
(together with
re-assembly)

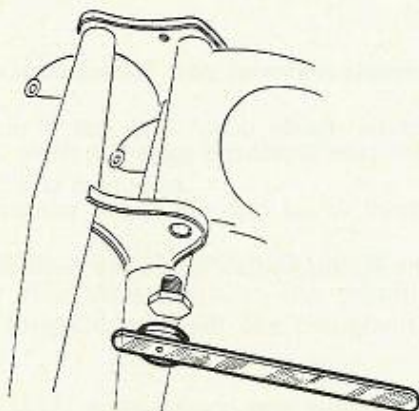

Wrench MB 16992
for steering tube lower screw



Freeing the assembly

— As in the case of Operation No. 19, drain the tank, remove the saddle and seat post and rest the machine on the stand. Remove the front wheel and disconnect the lighting wires in the headlamp.

- Remove the headlamp using the 10 or 14-mm socket wrench.
- Remove the Timbrelec bell or horn, if any, after disconnecting wires using the 10-mm socket wrench.
- Unlock the steering tube lower screw (chisel).
- Loosen and remove the steering tube lower screw using the 32 mm wrench MB-16992 VAR-58/32.
- Remove both securing screws and the single locating screw of the twist grip using the screwdriver and the 8-mm wrench.
- Remove both handlebar yokes using the 10-mm socket wrench.
- Remove the twist grip ; guide it between the dampers to turn it loose.
- Unscrew the upper 8-flat lockscrew (32-mm wrench MB-1229 VAR-335).
- With a hard wood block, hammer the edge of the lower plate to free the assembly.
- Pull the forks forward and lift to disengage them from the upper part the threaded tube.
- Unscrew the top bearing cup ; be careful to retain the balls. Use the multiple pliers.
- Remove the threaded tube : rotate slightly to let the balls remain in the bottom bearing cup).
- Proceed as in Operation No. 19 if the steering unit must be replaced.

NOTE

If equipped with a firm stand (repair bench, hoist bench, multi-purpose bench), the repairer may do without turning the machine upside down, and therefore he does not need to drain the tank. In such a case, be very careful not to lose the balls when removing the threaded tube.

COMPLETE DISASSEMBLY OF THE TELESCOPIC FORKS (OPERATION N° 21)

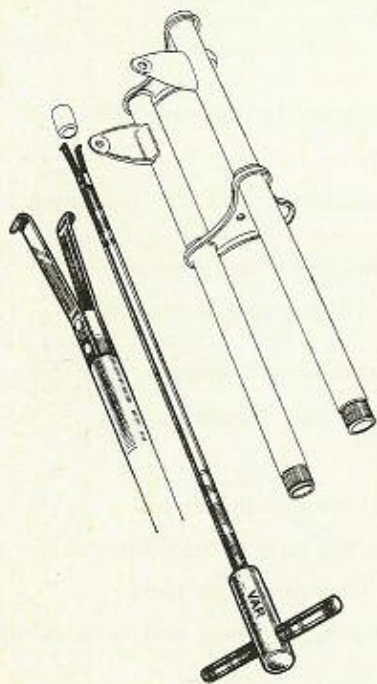

F.T. bush extractor N° 1320



Bush adjustment wrench N° 1354

Adjustment key wrench n° 1354, used as a dummy plunger, is also quite useful for aligning bushes on telescopic forks of all other models.

- Clamp the lower member plate in a vise fitted with felt-protected jaws.
- Unscrew both upper knurled nuts retaining the plunger springs using multiple pliers or a pin screwdriver.
- Also unscrew both bottom knurled nuts from forks using multiple pliers.
- Pull out both plungers (with spring and upper fastener) through the bottom end.
- Extract the graphited nylon bushes and bush spacers using extractor MB-1320 VAR-360
- Remove the forks embellishers, according to the type of the machine.
- Proceed reversely for re-assembly. **AVOID TIGHTENING the bottom knurled nuts before the plungers are installed.** This allows position to the bushes correctly.

NOTE - SP 50 R and 89 new model

on " wide " forks equipping these machines, the bottom set of nuts n° 17824 (retaining the nylon bushes) are screwed inside the dampers (adjusting wrench MB-1354 VAR-397).

When assembling, lock the nuts by smearing the thread with a plastic glue similar to " Loctite, grade C " (1).

(1) CHAMPION - 87, Avenue Niel, Paris (see manual).

TOOLS REQUIRED
Multiple pliers
Extractor MB-1320
9 mm socket wrench
Adjusting key MB-1354

Average time required : 30 mn (without re-assembly).

REPAIRING A LEVER ACTION FORK (type 89 former model) (OPERATION N° 22)

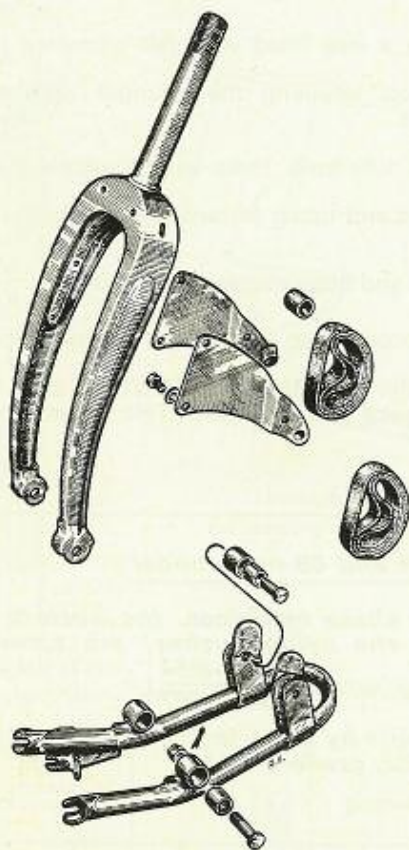

Lever-action fork

TOOLS REQUIRED

12 mm socket wrench	10 mm socket wrench
16 mm socket wrench	Wrench MB-1229
Screwdriver	24 mm socket wrench
Multiple pliers	

— As in Operation No. 19, drain the tank, remove the saddle and seat post and rest the machine upside down on a stand.

- Disconnect the speedometer and brake controls connected to the front hub.
- Remove front wheel using a 16-mm socket wrench.
- Disconnect the lighting wires located inside the headlamp, and the Timbrelec bell or horn wires.
- Pull out the front brake and speedometer controls (housed inside the fork).
- Remove the handlebar and the control grips using a 12-mm socket wrench.
- Unscrew and remove the upper 8-flat lock nut using a 32-mm wrench ^{MB-1229} VAR-335.
- Remove both front guard securing screws using a 10-mm socket wrench.
- Remove the front guard.
- Unscrew the top bearing cup using multiple pliers ; retrieve the balls.
- Pull out the forks by rotating it slightly so as to leave the balls in the bottom cup.
- Clamp the fork by the threaded tube in a vise with lead or copper jaws.
- Remove the front mudguard secured to the fork by four screws and nuts using a 10-mm socket wrench.
- Extract the bottom cone secured to the base of the threaded tube.
- Remove both back-plates securing the Neiman bushes using a 12-mm socket wrench.
- Remove the pin and unscrew the nuts, then remove the fork lever hinge pins using a 14-mm socket wrench.
- Mill and pull out the rivets securing the Neiman bushes to the fork lever.
- Proceed reversely for re-assembly.

Average time required : 3 hour 30 minutes. (Together with re-assembly by operating in reverse order.)



REPLACING A PULLEY (a) AND A BOTTOM BRACKET AXLE (b) (OPERATION N° 23)

CAUTION

For this operation special attention should be paid to the throttle, choke and decompression controls which are very tight. **Place a rest under the engine** and disconnect the decompression control.

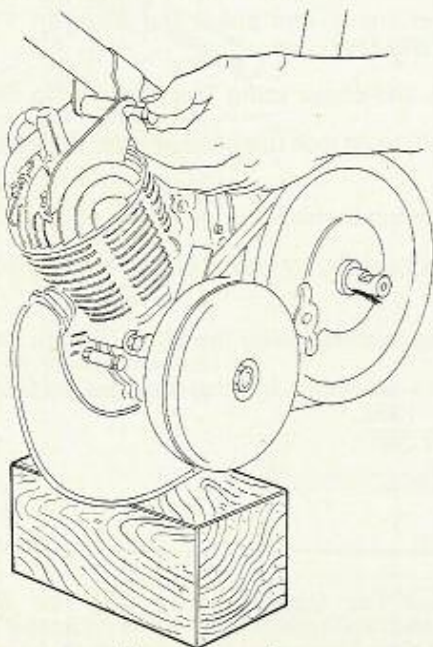

Rest under engine

a) REPLACING A PULLEY

This operation is applicable to all Mobyette types except roller drive machines.

- Remove the left-hand side guards except for the belt protector on machines not fitted with a variator.
- Trip the belt. On machines not fitted with a variator, unlock the lower engine attachment bolt and remove the upper one using a 12-mm socket wrench in order to disengage the pulley. **BE CAUTIOUS.**
- Remove the belt.
- Remove the left-hand crank (11-mm socket wrench).
- Unfasten the quick-release of the engine drive chain.
- Remove the pulley oil-protection cup, circlip and bottom bracket spindle cheek using Truarc pliers No. 988.
- Pull the pulley out.

Average time required : 1 hour.

b) REPLACING A BOTTOM BRACKET AXLE. SEE NOTE BELOW

- Carry out the above operations.
- Remove the right-hand side chain guard and the chain using the screwdriver and combination pliers.
- Remove the right-hand crank using an 11-mm socket wrench.
- Remove the two circlips and the cheeks using Truarc pliers No. 988.
- Extract the bottom bracket axle.
- Proceed reversely for re-assembly.

Average time required : 1 hour 30 minutes.

NOTE. Mobyettes 89 and SP 50 have a flanged bracket axle with only one retaining circlip which must therefore come out on the left-hand side. The SP 50 R is fitted with a spindle with crank release in the footrest position. Remove on right-hand side the circlip, the cup, the loading spring, and extract the right-hand crank. The spindle must come out on the right-hand side.

TOOLS REQUIRED

Screwdriver
12 mm socket wrench
11 mm socket wrench
Truarc pliers N° 988
Combination pliers

REPLACING THE BOTTOM BRACKET AXLE BUSHES (OPERATION N° 24)

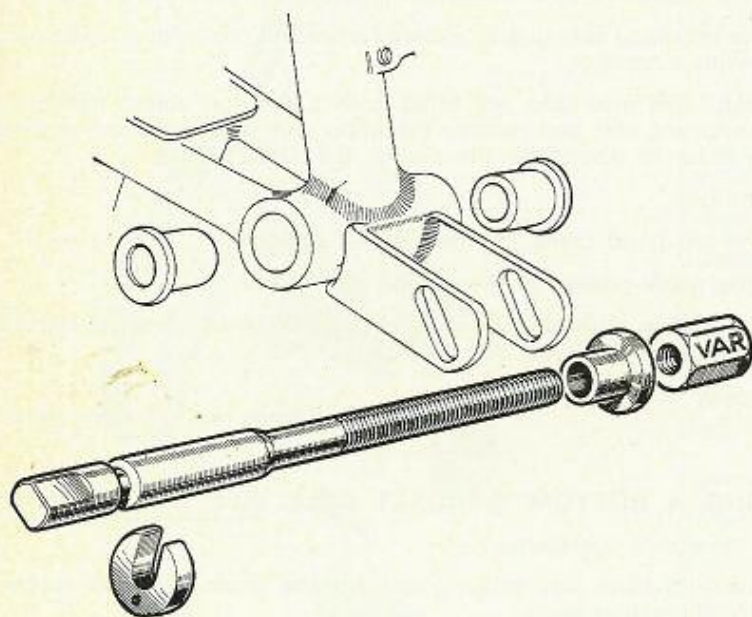

Tool N° 1352 to insert the bottom bracket bushings

TOOLS REQUIRED

Screwdriver	Steel discard head
Combination pliers	Tube, 20 or 22 mm dia.
12 mm socket wrench	Pointed chisel
11 mm socket wrench	10x12 mm end wrench
Truarc pliers N° 988	19x21 mm end wrench

Average time required : 2 hours.

- Remove the chain guards using a screwdriver.
- Remove both engine and pedal drive chains using combination pliers.
- Remove the belt (operation No. 23).
- Remove the right-hand crank, and pull it out using an 11-mm socket wrench. **SEE NOTE BELOW.**
- Remove spindle circlip and cheek using Truarc pliers No. 988.
- Remove through the left-hand side the bracket axle, pulley and left-hand crank.
- Make a notch with a pointed chisel in one of the axle bushes.
- Drive out the notched bushing by means of a steel discard head inserted in the bottom bracket.
- Drive out the remaining bushing using the 20- or 22-mm steel tube.
- Proceed reversely for re-assembly, but use the **tool to fit the bottom bracket bushes**
 MB-1352
 VAR-391.

NOTE. As specified for Operation n° 23, for SP 50 R machines the spindle must be extracted on the right-hand side after removing the left-hand crank, pulley, circlip and cheek.

- After removing the securing screw, extract the right-hand side bush which acts as a stop for the release crank.
- Then drive out the left-hand side bushing with a 20 or 22 mm dia. tube.

DISASSEMBLING OR RE-ASSEMBLING

A) FLEXIBLOCS ENGINE HINGE - B) HUB BEARINGS

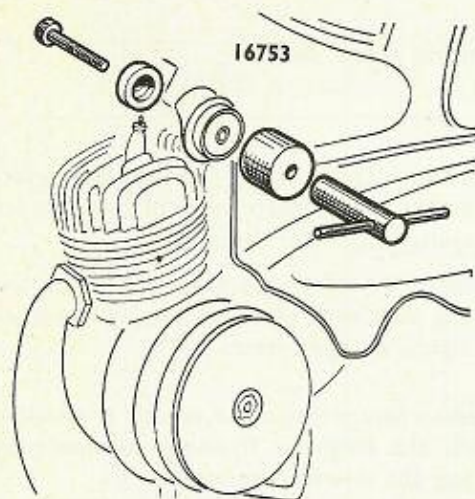

Tool for fitting and extracting Flexiblocs engine hinge

a) Disassembling or re-assembling the flexiblocs engine hinge

- Tool No. 16753 is absolutely necessary for these operations.
- For insertion, introduce from inside the "Flexibloc" **chamfered end first.**
- To position or extract, proceed from inside to outside.

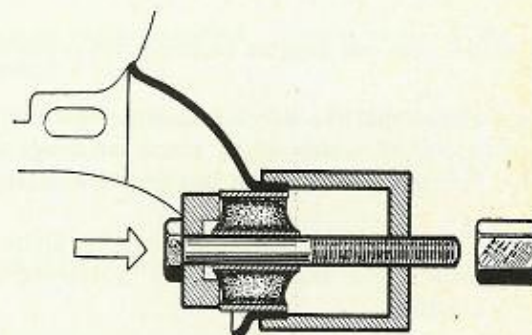

diamètre	10	16902
diamètre	12	16787

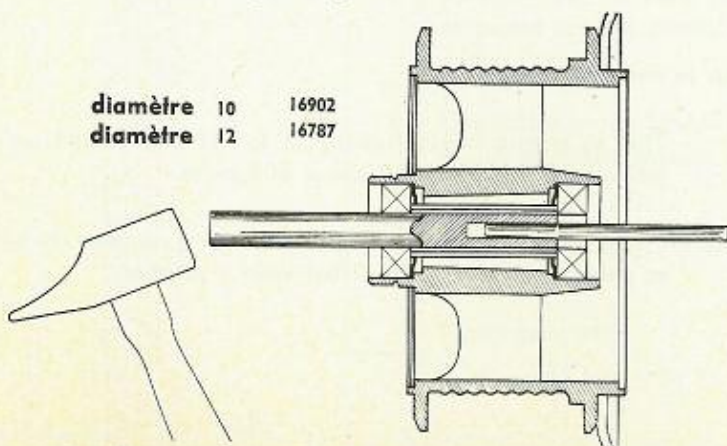

Bearing extractor for the Mobylette rear hub

b) Disassembling the hub bearings.

- This is a convenient tool to extract the hub bearings:
For 10-mm dia. axle, No. 16902.
For 12-mm dia. axle, No. 16787.
- Insert the 10- or 12-mm rod into one of the bearings so that its split end comes flush with the inner side of the other bearing.
- Insert the tapered rod through the latter and expand the 10- or 12-mm dia. rod. Then drive out the bearing.

POOR PERFORMANCE

More often than not, poor performance should not be ascribed to the engine itself but to one or several frequently unsuspected secondary causes. (1)

In such a case, we suggest to check the following :

- 1°) - Check that the decompression control is not or has not been too tight, which might possibly damage the valve and entail compression loss (this is a frequent cause).
- 2°) - Check that the throttle opens fully. Quite often its control is maladjusted and the engine is starved even at full throttle position.
- 3°) - Check that there is no braking action due to excessively taut chains. In this respect, on Mobylettes fitted with a swinging arm rear suspension, **tension adjustment must be performed in running position, the machine loaded with a rider weighing about 165 lb.**
- 4°) - Check that there is no braking action due to an excessively taut belt (machines without a variator).
- 5°) - Check that the brake controls are correctly adjusted.
- 6°) - Check that the filler cap vent hole is not clogged as this may bring about poor fuel supply.
- 7°) - Check that the spark plug is in accordance with the manufacturer's specifications.
- 8°) - Check that poor performance is not just a case of exhaust fouling, mainly in the elbow.

- 9°) - **Very important note.** - Quite often, poor engine performance may be caused by an overtightening of the cylinder head nuts, which results in cylinder distortion.

In this respect, it must be mentioned that these nuts are finally tightened in the plant with precision torque wrenches and should not be tightened again later.

- 10°) - However an unforeseen failure may occur, mostly in ignition. In such event check the magnetic flyweight components, external H. T. coil and the interference screen.

Keep in mind :

- That an engine needs running in for 300 miles and only yields its full power after about 600 miles.
- That a Mobylette that is not fitted with a variator is not as good a climber as one fitted with a variator.

-
- (1) - All our engines are bench-tested and their efficiency curve plotted with high accuracy.

The machines themselves are submitted to a final test before shipment.



POOR IGNITION OPERATION

(MAGNETIC FLYWHEEL AND IGNITION SYSTEM)

FAILURE	PROBABLE CAUSES	REMEDIES
<p style="text-align: center;">I</p> <p>Engine does not start or starts with difficulty.</p>	<ol style="list-style-type: none"> 1 - Fouled or faulty spark plug. 2 - Contact points do not space out, or do not space far enough (worn or broken rubbing block). 3 - Moving contact jammed. 4 - Broken spring. 5 - Foreign body between contact points. Burned or pitted contact points. 6 - Condenser and/or ignition coil faulty or weak; supply armature seldom at fault. 7 - Ignition coil leaky (visible charred point). 8 - Faulty supressor. <p style="text-align: center;">Caution : type M 23 - external coil. type M 24 - internal H. T. armature.</p>	<ol style="list-style-type: none"> 1 - Replace with specified original type. Gap width 0.4 mm. 2 - Adjust max. gap at 0.3 mm. Replace contact breaker if necessary. Check cam condition and replace it if necessary. 3 - Sand slightly. Refit with a drop of graphite oil. 4 - Replace the contact breaker. 5 - Face contact points. Replace the contact breaker if necessary. Check condenser and lead condition which might well be the cause. 6 - Check on Bermascope. Replace if necessary. 7 - Replace it. Do not lose contact spring. 8 - Replace it.



POOR IGNITION OPERATION (continuation)

(MAGNETIC FLYWHEEL AND IGNITION SYSTEM)

FAILURE	PROBABLE CAUSES	REMEDIES
<p style="text-align: center;">I</p> <p>Engine does not start or starts with difficulty.</p>	<ul style="list-style-type: none"> 9 - Condenser lead shorted on plate or broken. 10 - Magnet holder offset in rotor, with consequent magnetic field shift. 11 - Faulty ignition timing. (too much or too little advance). 	<ul style="list-style-type: none"> 9 - Replace the lead or assembly according to model. 10 - Replace the rotor. Check voltage. 11 - To be checked.
<p style="text-align: center;">II</p> <p>Poor start or misfires, lights work.</p>	<ul style="list-style-type: none"> 1 - Gap between contact points too wide. 2 - A rare occurrence : demagnetized rotor. 	<ul style="list-style-type: none"> 1 - Permissible max gap 0.3 mm. 2 - Test another rotor of the same voltage.
<p style="text-align: center;">III</p> <p>Engine works improperly at high R. P. M.</p>	<ul style="list-style-type: none"> 1 - Self-ignition or spark plug hot point due to fouling. 2 - The moving contact rotates with difficulty. 3 - Loose moving contact spindle. 4 - Excess play of contact on spindle or weak spring (a rare occurrence). 5 - Contact breaker connection bracket loose. 6 - Condenser failure (carburettor knocks). 7 - Failure of ignition coil or armature. 	<ul style="list-style-type: none"> 1 - Sand blowing or replacement of spark plug. 2 - Slightly sand spindle. Refit with a drop of graphite oil. 3 - 4 - Replace contact breaker. 5 - 6 - Check on Bermascope. 7 - Replace if needed.

Mobylette

IceniCAM Information Service

