

# JAMES

INSTRUCTION BOOK

1958 MODELS LI & LI5



**COMET  
100**

**CADET  
150**



MANUFACTURERS :  
JAMES MOTOR CYCLES LTD  
GREET, BIRMINGHAM 11

PRICE: 2/6

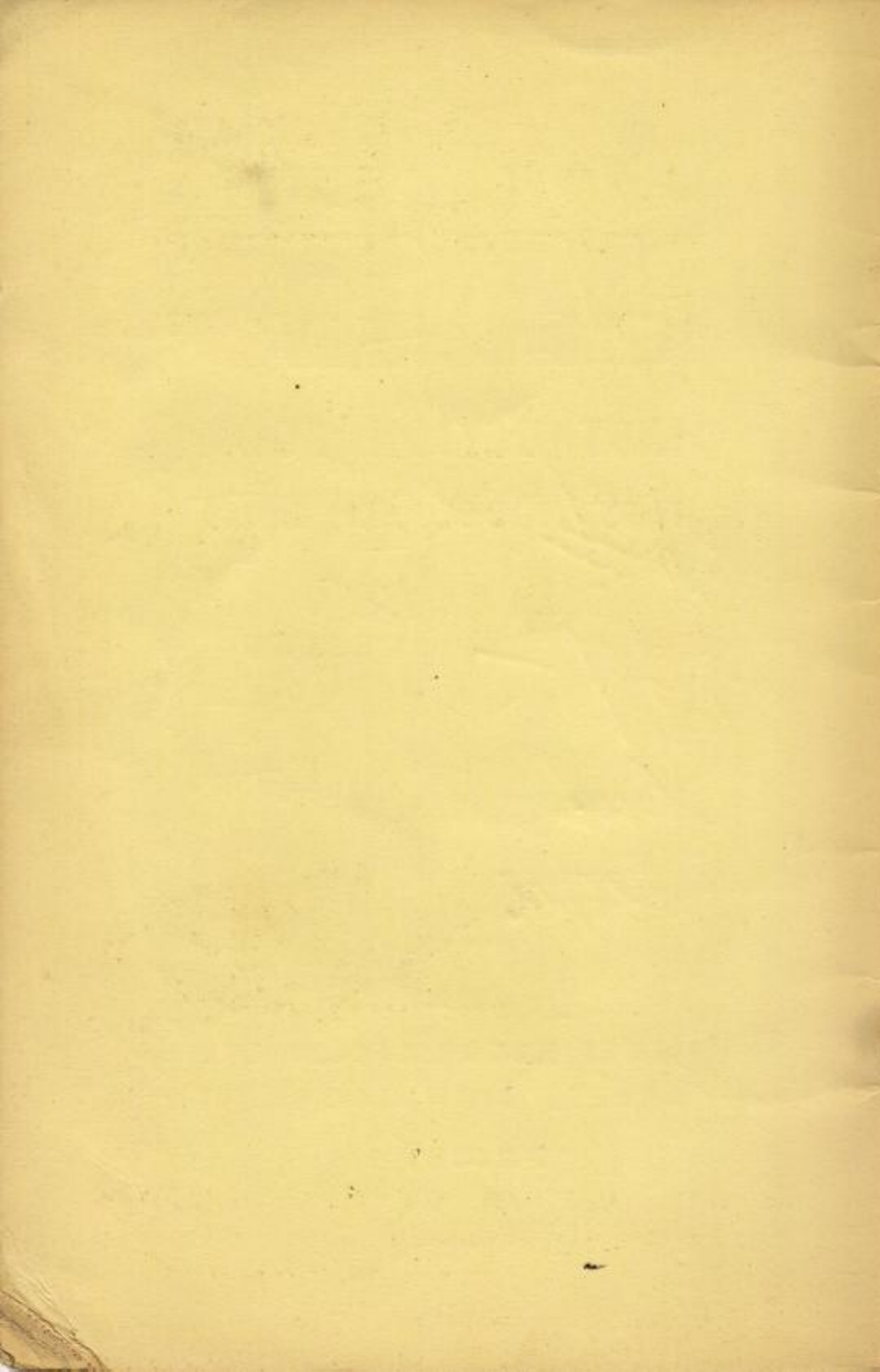



# JAMES

INSTRUCTION BOOK - 1958 MODELS

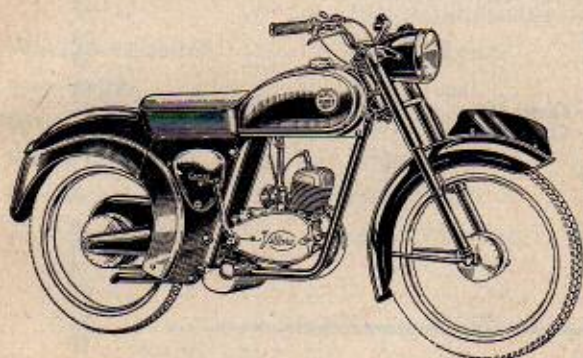

*Comet 100*  
MODEL L1

*Cadet 150*  
MODEL L15

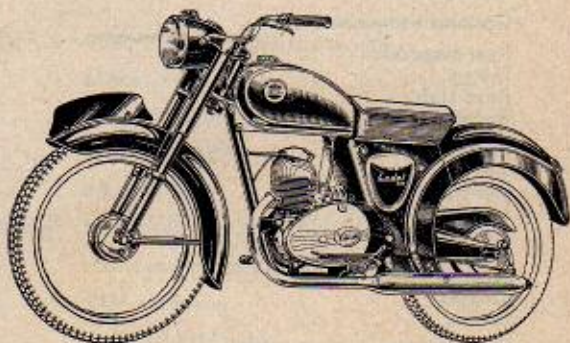

**JAMES MOTOR CYCLES LIMITED**  
**GREET : BIRMINGHAM, 11 : ENGLAND**

Telephone : VICTORIA 2211

Telegrams : JAMESGREËT, BIRMINGHAM (Telex)

## CONTENTS

Brakes .. .. .	17
Bulbs — Comet 100 .. .. .	54
" — Cadet 150 .. .. .	55
Cables .. .. .	10
Carburettor — Comet 100 .. .. .	31
" — Cadet 150 .. .. .	34
Chains .. .. .	20
Cleaning .. .. .	50
Clutch — Comet 100 .. .. .	29
" — Cadet 150 .. .. .	40
Condenser .. .. .	43
Contact breaker — Comet 100 .. .. .	24
" — Cadet 150 .. .. .	42
Controls .. .. .	6
Decarbonising .. .. .	47
Engine — Comet 100 .. .. .	23
" — Cadet 150 .. .. .	38
Fault Finding chart .. .. .	52, 53
Flywheel magneto — Comet 100 .. .. .	25
" — Cadet 150 .. .. .	41
Frame .. .. .	16
Free Service Scheme .. .. .	4
Fuel .. .. .	7
Gearbox — Comet 100 .. .. .	28
" — Cadet 150 .. .. .	44
General Information .. .. .	4
Guarantee .. .. .	61
Headlamp .. .. .	54
Hubs .. .. .	17
Law .. .. .	5
Lighting .. .. .	54
Lubrication .. .. .	9
Maintenance .. .. .	11
Optional equipment .. .. .	51
Rear suspension .. .. .	15
Riding .. .. .	7
Road craft .. .. .	8
Running-in .. .. .	8
Service Department .. .. .	27
Silencer .. .. .	48
Spare parts supply .. .. .	43
Sparkling plug .. .. .	46
Speedometer drive .. .. .	19
Starting .. .. .	7
Steering stem .. .. .	14
Stopping .. .. .	8
Spokes .. .. .	19
Technical data — Comet 100 .. .. .	58
" — Cadet 150 .. .. .	59
Timing ignition — Comet 100 .. .. .	26
" — Cadet 150 .. .. .	43
Throttle twistgrip .. .. .	15
Tracing trouble .. .. .	48
Training .. .. .	9
Tyres .. .. .	20
Wheels .. .. .	17
Wiring diagram — Comet 100 .. .. .	54
" — Cadet 150 .. .. .	55



## **Foreword**

Skilled design and construction have made your James lightweight as safe as possible. It has first-class steering and brakes and is very easy to handle in traffic. The very manoeuvrability of your machine makes it necessary to exercise caution at



all times. Take a pride in your riding technique: your example of courteous, careful and unobtrusive riding will materially contribute to road safety and to the reputation of a fine sport.

In operation, a James is as simple as it is possible for a high efficiency motor cycle to be and only the minimum of attention is necessary for it to give you many thousands of miles of reliable and economical personal transport.

We hope that the information given in the following pages will help both novice and experienced rider, for even the owner with many years of motor cycle riding behind him may commit errors in the care and maintenance of a new machine which may cause serious and expensive damage. The purpose of this booklet is to acquaint you with important details concerning your motor cycle and to indicate those parts which require special care or regular lubrication.

It is in your interest to observe these instructions carefully. The service life, driving safety, and reliability of your James depend on the care you give it. Please consider this booklet as a guide destined to bring you quickly and safely to your destination.

**JAMES MOTOR CYCLES LTD.**

# General Information

## FRAME AND ENGINE NUMBERS.

Your James motor cycle is stamped with frame and engine numbers and it is in your interests to record these numbers in the spaces below. The numbers enable identification of the machine and must be quoted in any correspondence relating to your motor cycle.

**FRAME NUMBER :** On the left-hand side of the steering head tube on both models L1 and L15.

**ENGINE NUMBER :** Comet 100 — model L1. On left-hand side of crankcase immediately below cylinder joint.  
Cadet 150 — model L15. On top of crankcase front engine lug.

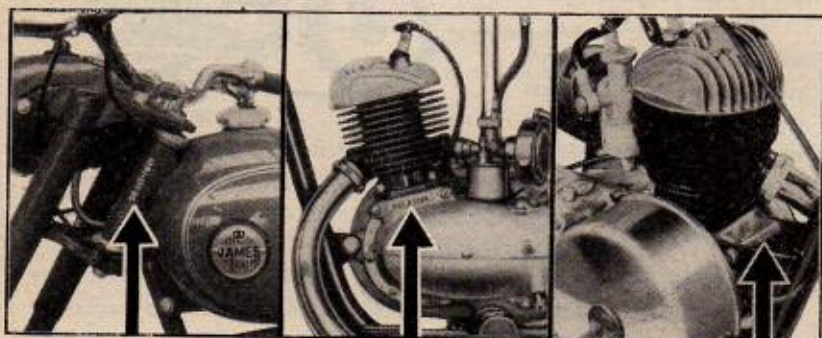

FRAME NUMBER

ENGINE NUMBER—COMET 100

ENGINE NUMBER—CADET 150

RECORD YOUR FRAME AND ENGINE NUMBERS HERE FOR REFERENCE

FRAME	ENGINE

## FREE SERVICE SCHEME. (UNITED KINGDOM).

All owners of **NEW MODELS** are entitled to one **FREE SERVICE AND INSPECTION** at 500 miles, or, at latest, three months after taking delivery.

This service is arranged by the supplying dealer to whom the **Free Service Card** must be handed. This voucher will be found in the tool box upon taking delivery of a new motor cycle.

The **INSPECTION AND SERVICE** consists of :

- (a) Check, and, if necessary, adjust :
  - (1) Contact breaker points.
  - (2) Sparking plug.
  - (3) Clutch.
  - (4) Chains.
  - (5) Wheel bearings.
  - (6) Brakes.
  - (7) Forks and rear suspension.
  - (8) Alignment of wheels.
  - (9) Tyre pressures.
- (b) Tighten all external nuts and bolts, including cylinder bolts.
- (c) Check all lighting equipment.
- (d) Clean out carburettor and adjust mixture.
- (e) Adjust and lubricate all cables.
- (f) Grease all nipples.
- (g) Check oil level in primary chaincase.
- (h) Top-up gear box.
- (i) Test machine on the road.

**NOTE :**—Oils, greases and materials used are chargeable to the customer.



## THE MACHINE AND THE LAW. (UNITED KINGDOM).

Every motor cycle used on the public roads of Great Britain must be registered and carry the registration numbers and licence disc allotted to it. The dealer from whom the machine is bought will generally attend to all matters legally essential before it is used on the public roads.

### TO REGISTER A NEW MACHINE

Send the Local Motor Tax Department the following :

- (a) Form "RF1/2," duly completed.
- (b) The certificate of insurance.
- (c) The invoice you received from your dealer when you purchased the machine.
- (d) The appropriate registration fee.

In due course you will receive :

- (1) A Registration Book. (Commonly called the "log" book).
- (2) A Licence Disc.
- (3) Your Insurance Certificate.
- (4) Your Invoice.

The Registration Book and the Licence Disc will bear the registration numbers that have been allotted to your machine and will also show the date the road licence expires. Your number plates must then be painted, in white upon a black background, with the registration numbers in characters of even thickness as follows :

The numbers on the front plate must be  $1\frac{3}{4}$ " high,  $1\frac{1}{4}$ " wide and  $\frac{3}{16}$ " thick with spaces of  $\frac{1}{2}$ " between each two characters.

The numbers on the rear plate must be  $2\frac{1}{2}$ " high,  $1\frac{3}{4}$ " wide and  $\frac{3}{8}$ " thick with spaces  $\frac{1}{2}$ " between each two characters.

The Licence Disc must be enclosed in a watertight container, having a glass front, and this must be fixed to the machine in a conspicuous position, near the front and on the left-hand side.

Although it is not legally necessary to carry your Driving Licence, Insurance Certificate and Registration Book while driving your machine, it should be noted that Police Officers have authority to ask for the Driving Licence and Insurance Certificates at any time.

### SPEEDOMETER.

A speedometer **MUST** be fitted to all motor cycles over 100 cc. It is supplied as standard equipment on the James Cadet 150 and available as an optional extra for the Comet 100.

### LAMPS.

During the official "LIGHTING UP" hours the machine must exhibit a white light facing forwards and a red light facing rearwards. The rear number plate must be adequately illuminated by a white light.

Each electric light bulb **MUST** be marked with its "Wattage." (Beware of cheap, imported bulbs, that do not have this marking.)

All motor cycles made by us have electric equipment that complies with the law regarding position, size of bulbs, marking on bulbs and the correct illumination of the rear number plate.

### REFLECTOR.

All solo motor cycles **MUST** display a reflector on the rear mudguard as well as a tail light. Reflectors should be  $1\frac{1}{2}$ " in diameter mounted so that the reflecting surface faces squarely to the rear at a height between 15" and 42" from the ground.

On the Cadet 150 the Wico-Pacy tail light incorporates a reflector surface which complies with British traffic regulations.



# Controls

**FILLER CAP.** On top of fuel tank. Incorporates oil measure for petrol mixture. (4 measures of oil to one gallon of petrol). Push in and pull out.

**FUEL TAP.** On left under tank. Pull knob to turn fuel ON. Push in to turn fuel OFF. Always push knob to Off position when stopping for any length of time.

**AIR SHUTTER.** Slide fitted on carburetter air filter. Close to enrichen mixture for starting. Use in conjunction with tickler.

**TICKLER.** Small knob on carburetter body. Depress until petrol appears on carburetter body, to provide rich mixture for starting.

**THROTTLE TWIST GRIP.** On right handlebar. Controls speed of engine. Twist towards rider to open. Away from rider to close.

**KICK STARTER.** Vertical lever with folding crank on right of gearbox. Use to start engine.

**CLUTCH LEVER.** On left handlebar. Pull towards handlebar to release engine drive from rear wheel. Use when moving away from rest and also when changing gear. Always ease the clutch in gently.

**GEAR CHANGE LEVER.** (Comet 100) \* Small lever on right handlebar. Push smartly forward to engage Low gear. Pull towards rider to engage High gear. Neutral is between Low and High gears. A ratchet provides positive location.

**GEAR CHANGE PEDAL.** (Cadet 150) Horizontal lever in front of right-hand footrest. Move UP to select a lower gear. Move DOWN to select a higher gear. Neutral is between First (Bottom) and Second gear.

The pedal will always return to the same position and the foot should be removed from lever between each gear change. Grip the clutch lever when changing gears.

**FRONT BRAKE LEVER.** On right handlebar. Grip to operate front brake. Apply in conjunction with rear brake for maximum braking efficiency.

**REAR BRAKE PEDAL.** In front of L/H footrest. Press down to operate rear brake.

**LIGHTING SWITCH.** (Direct lighting set—AC. equipment). In top of headlamp. Switch has three positions :

L	Pilot and rear lamps lit (when dry battery is fitted).
OFF	No lamps in use.
H	Head, rear and speedo lamps lit.

**LIGHTING SWITCH.** (Rectifier/Battery lighting set—AC—DC equipment). In top of headlamp. Switch has 4 positions :

OFF	No lamps in use.
P	Parking lights in use — current supplied by 6 volt battery.
H	Headlamp, tail light and speedo light in use, current supplied by battery.
DIRECT	Headlamp, tail light and speedo light in use—current supplied from flywheel generator with engine running.

**DIPSWITCH.** On left handlebar. Deflects main headlamp beam downwards and to the left. Prevents dazzling oncoming drivers.

\* Where optional foot change mechanism is fitted refer to page 30



# Riding

**FUEL.** When the machine first comes into the hands of the rider it will be ready, but for fuel, for the road.

Villiers two-stroke engines employ the petroil method of lubrication and the recommended ratio is 1 part of oil (SAE 30) to 20 parts of petrol. It is advisable to mix the fuel in a tin before filling the tank, but if this is not possible make sure the tap is turned off, pour oil into the tank before the petrol and shake the machine from side to side. The filler cap incorporates an oil measure. If this is used 4 measures of oil per 1 gallon of petrol provide the correct ratio. Another method is to mix  $\frac{1}{2}$  pint of oil with  $1\frac{1}{2}$  gallons of petrol.

The following oils are recommended : Mobiloil A, Shell X 100-30, Castrol XL, Energol SAE 30, Essolube 30.

A small reserve of fuel, sufficient to cover 3 to 5 miles, is provided. If it is necessary to use it, incline the machine to the left.

**STARTING.** See that there is sufficient fuel in the tank.

Ensure gear lever is in NEUTRAL by rolling machine slightly forwards and backwards. (Neutral is between bottom and second gear).

Pull fuel tap to ON position.

Close shutter on air cleaner and depress tickler until fuel appears.

Open twist grip about a quarter of its travel.

Standing over machine, depress kickstarter with a steady swinging movement.

When engine starts do not forget to open the air shutter as fully as possible.

Re-starting when the engine is warm will require no flooding of the carburetter, neither will it be necessary to close the air shutter.

**FAILURE TO START.** Commonly caused by over flooding carburetter. If repeated kicks fail to start after flooding (when cold) shut off the fuel supply, open throttle wide and clear crankcase of excessive fuel by turning the engine over rapidly with the kick starter pedal until it fires. Then do not close throttle but keep wide open until engine revolutions have built up and running is normal.

**ERRORS IN STARTING.** Mistakes often made whilst starting a motor cycle are :—

Opening throttle too wide ; thus destroying the advantage of a rich mixture.

Failure to lean the machine slightly to the left, so that pressing of the foot on the kick-starter causes rider and machine to overbalance.

Tickling the carburetter insufficiently. This operation must produce a head of fuel on the top of the carburetter body.

These faults are easily corrected with care and will result in greatly improved starting.

**ON THE ROAD.** Having started and warmed up the engine and sitting astride the machine, disengage the clutch and engage low gear (push hand gear lever forward on Comet 100\* — move gear pedal upwards with toe on Cadet 150). Next, release the clutch lever slowly and as the machine starts to move forward, open the throttle gently to enable the engine to take up the load. Increase speed gradually and when well under way, disengage the clutch, close the throttle a little and select the next gear (top on the Comet 100\* by pulling hand gear lever towards you — second on the Cadet 150 by pressing the pedal down). On the Cadet 150 change into top gear at approximately 20 m.p.h. The gear change hand lever or foot pedal must be moved to the full extent of its travel when selecting a gear.

The change from a high gear to a lower gear is made in a similar manner. A little practice will probably be necessary in order to change gear with ease and certainty, with all movements correctly synchronised, but the gears are very easy to manipulate and will present little difficulty. The gear change mechanism on a new machine is generally a little stiff and will ease considerably when the machine has been run-in.

\* Where optional foot change mechanism is fitted refer to page 30.



**STOPPING.** Before slowing down glance to the rear to ascertain what vehicles are following and if necessary give the signal "I am going to slow down." (Full details of road signals will be found in The Highway Code available from H.M. Stationery Office).

When slowing down, change into a lower gear. The engine will thus assist the wheel brakes. As speed decreases to a few m.p.h., raise the clutch and select neutral, applying the brakes for the last few yards before stopping. When stopping (except in emergencies) apply the brakes gently and gradually. When the machine is to be left standing for any length of time, it is advisable to turn off the fuel supply when approaching destination, allowing the engine to use up the supply of fuel in the carburettor whilst coming to rest. This avoids the possibility of oil globules separating from the petrol and choking a carburettor jet.

**RIDING IN TRAFFIC.** In slow moving traffic engage lower gears. This permits the engine to run smoothly and enables overtaking to be accomplished in the minimum of time. The engine must never be allowed to labour, and the judicious selection of the right gear will prolong the life of the engine and the transmission system. Slipping the clutch should be avoided. Whenever in doubt about overtaking, always hang back.

**RUNNING-IN.** The manner in which a new motor cycle is driven during the first 1000 miles (1600 kms.) can make or mar its eventual performance and useful life, and owners are therefore strongly advised to exercise great care during the vital "running-in" period. Despite the most careful manufacture and assembly, new bearing surfaces have microscopic idiosyncrasies not entirely suited to the opposite surface and the initial period of "light duties" will give those working parts a mirror finish impossible to achieve by machinery.

Two-stroke engines are quickly run in, owing to their simple and efficient design. However, here, as in everything else, treatment must follow the dictates of common sense, and not too much should be attempted on the first ride. Do not exceed 30 m.p.h. in top gear on level roads for the first 500 miles and limit the throttle opening to two-thirds of its travel until at least 1,000 miles have been covered. Never let the engine labour on hills or in traffic, but change down to a lower gear so that the engine turns over lightly at all times.

After 1,000 miles greater throttle openings and short bursts of speed may be indulged in, but full throttle running over long periods should always be avoided. During the running-in period many other parts "bed down" and all nuts should be checked with a spanner for tightness after 200 miles. Check also the spark plug gap, chain, and brake adjustments.

---

## *Road Craft*

Take a pride in your riding technique: there are, unfortunately, a few motor cyclists whose reckless driving constitutes a menace, not only to themselves but to other road users. Your example of courteous, careful and unobtrusive riding will materially contribute to road safety and to the reputation of a fine sport.

One of the most important rules to remember is: Before moving off, pulling out to overtake, turning right and turning left, glance over your shoulder to make sure it is safe to do so and if necessary give the correct signal.

If at first bottom gear will not engage whilst the machine is stationary, do not resort to force—simply raise the clutch and move the machine backwards and forwards for a second or two, then try again. In time this condition will disappear.

Take pride in making a smooth start; it is not clever or wise to race the engine and then let the clutch in suddenly to make a flying start. Make a smooth getaway after first glancing to the rear and signalling your intention.



Always drive on the engine and not on the brakes, thereby saving expense on brake linings. Remember that an engine in low gear is a safe and sure brake and that skidding is well-nigh impossible when using it so.

Change gear on hills **BEFORE** the engine has commenced to labour; a good driver will learn to anticipate such a condition, and change down early.

When changing gear move the foot or hand lever to the full extent of its travel firmly and smoothly, at the same time as the clutch is disengaged.

Cornering. When approaching an uncertain bend at speed, change down if necessary and brake **BEFORE** entering the curve. On a left-hand bend, ease over near the crown of the road in order to sweep in close to the verge once round the corner. On a right-hand bend, always keep well into the verge. Never accelerate into a bend.

When using the brakes, apply gentle pressure at first, increasing in strength as the road speed decreases. Never brake hard unless the machine is vertical.

Use your full headlight when riding at night unless in brightly lit streets.

Make full use of the dipswitch whilst riding at night; this is a "courtesy control" and its use will be appreciated by oncoming drivers.

Always reduce speed when your visibility is lowered.

Many accidents are caused by rash over-taking. Be cautious, remembering that a small engine has not the acceleration of a larger machine. Every car driver has a blind spot in his mirror within which he cannot see you. Make sure that he knows you are there if you are overtaking. Similarly glance behind you before pulling out.

Remember that pedestrians, young or old, are the most likely to make unexpected changes in direction and speed, step off pavements, come from behind stationary vehicles or, in country districts, suddenly appear round the curve of a blind bend. Constant observation and anticipation is required to avoid them.

## TRAINING FOR BEGINNERS.

Skill in motor cycling is not a gift. It has to be learnt and practised. Many clubs operate a scheme in co-operation with the R.A.C. and the A.C.U. for teaching young motor cyclists and beginners to become expert. For details apply to the Motor Cycle Department, Royal Automobile Club, 85 Pall Mall, London, S.W.1.

---

# Lubrication

Oil is the life blood of a motor cycle and it is most important that the correct type and quantity be employed in order to reduce power losses and wear to a minimum.

**ENGINE LUBRICATION — PETROIL SYSTEM.** This method of engine lubrication is very simple and practically foolproof. Oil is mixed with the petrol and since the mixture enters both crankcase and cylinder, all working parts receive a constant and fresh film of oil. As the amount of fuel used increases with wider throttle openings, a greater quantity of oil is supplied under arduous conditions. The recommended mixture is **ONE PART OF SAE 30 OIL TO TWENTY PARTS OF PETROL.** The mixture should preferably be prepared and well stirred in a can before filling the tank, but if this is not practicable, close the fuel tap and pour oil in the tank before the petrol, then shake the machine to ensure thorough mixing. The filler cap has a measure for oil and four measures to one gallon of petrol represent the correct 1 to 20 ratio. Alternatively,  $\frac{1}{2}$  pint of oil may be mixed with  $1\frac{1}{2}$  gallons of petrol. Certain oil companies provide special petroil dispensing pumps and these can be set to supply the 1 to 20 correct mixture. Always use a recommended brand:

**Mobiloil A**  
**Castrol XL**  
**Shell X100-30**

**Energol SAE 30**  
**Essolube 30**



**GEARBOX AND CHAINCASE LUBRICATION.** New machines are normally supplied with the correct grade and quantity of lubricant. It is, however, advisable to check oil levels before riding a new model.

On the Comet 100 power unit there is only one filler plug and one oil level plug. The filler plug is on top of the outer casing on the kickstarter side. The oil level plug is the hexagon on the inner casing on the same side. The oil should be checked every 500 miles and drained and replaced every 5,000 miles.

On the Cadet 150 engine, the gearbox filler plug is on top of the gearbox shell on the kickstarter side. A dipstick is screwed in alongside. To check oil level, remove dipstick and wipe it before checking that oil reaches the level notch ( $\frac{3}{8}$ " from bottom of stick) with the dipstick resting on top of the case. The primary chaincase has a filler plug at the top of the case and an oil level inspection plug near the bottom. The nut in the centre of the decorative motif holds the primary case cover in position. Always use one of the following brands :—

**Mobilube C140**

**Castrol D**

**Esso Gear Oil 140**

**Shell Dentax 140**

**Energol SAE 140**

**FRONT FORK — DAMPING AND LUBRICATING OIL.** The oil level should be checked every 5,000 miles by removing the two oil level grub screws retaining the mudguard bridge clips. If necessary top up with an oil can. The need to drain and refill is unlikely to occur but details are given on page 12. One of the following oils should be employed :—

**Mobiloil Arctic**

**Castrolite**

**Essolube 20**

**Shell X 100-20/20W**

**Energol SAE 20W**

**WHEELS AND STEERING HEAD BEARINGS LUBRICATION.** These items are packed with grease when new. They should however, be examined from time to time and it is advisable to dismantle, clean out with paraffin and pack with fresh grease every 5,000 miles. Use one of the following greases :—

**Mobilgrease M.P.**

**Castrolase Graphited**

**Esso Grease**

**Shell Retinax A or CD**

**Energrease C3**

**Esso Fluid Grease**

**REAR CHAIN.** If the rollers appear dry, oil with a brush and engine oil. Every 5,000 miles, remove and wash the chain in paraffin and soak in molten tallow or recommended grease.

**Mobilgrease M.P.**

**Castrolase Heavy**

**Esso Bearing Grease**

**Shell Retinax A or RB**

**Energrease C3**

**Esso Grease**

**MISCELLANEOUS PARTS.** Engine oil (SAE 30) is suitable for all small parts, cables, controls, brake pivots, stand pivots, etc. We recommend that these items be attended to every 1,000 miles but more frequent lubrication may be desirable in wet weather. Nuts and bolts should be smeared to prevent corrosion.

Avoid excessive use of oil on the control levers. It is likely to run along the levers and make them slippery and unpleasant to operate. If levers become loose at the pivot point, slackness can be taken up by tightening the pivot pin and locknut.

**CONTROL CABLES.** Control cables should be well lubricated to ensure smooth and sensitive operation. Cables may be oiled by squirting oil along the exposed lengths of inner cable and operating the control levers, but the limited movement makes it difficult for the oil to run through the entire length. If cables become stiff it is best to remove them completely and adopt the following procedure: Suspend the cable vertically and arrange a small "cup" either as a small paper cone attached to the outer cable by cellulose tape or moulded in plasticine, leaving the end of the outer cable exposed within the "cup." The cone can then be filled with oil which will slowly seep down the entire length of the cable. Cables should be left suspended overnight before replacing.



Small lengths of exposed inner cable should be smeared with grease. After a considerable mileage, cables may get damaged and replacements can be purchased from James stockists. The following part numbers should be quoted :—

Comet 100	Throttle cable ..	702031	Cadet 150	Throttle cable ..	702276
	Front brake cable ..	003637		Front brake cable ..	003637
	Clutch cable ..	002523		Clutch cable ..	001585
	Gear lever cable ..	704192		Speedometer cable	002348

---

## *Maintenance*

The efficiency and economy of your James can only be preserved by careful and regular attention to adjustments and lubrication. Neglect will result in poor performance, rapid depreciation and unnecessary expense.

By adhering to the following simple maintenance plan and the correct lubricants, wear will be reduced to the minimum and maximum performance obtained.

### **EVERY WEEK.**

Inspect tyres and check pressures.

Clean sparking plug.

Clean chrome and enamel parts.

### **EVERY MONTH.**

On models with Rectifier-Battery lighting remove battery, and top up with distilled water. Wipe off any surplus before replacing.

### **AFTER THE FIRST 200 MILES.**

Check and if necessary reset contact breaker points gap.

Check all nuts and bolts for tightness.

Check adjustment of rear chain.

Check steering head bearings.

Check adjustment of brakes.

### **EVERY 500 MILES.**

Inspect oil level in gearbox and primary chaincase. If necessary top up with correct grade of oil. **FILL TO LEVEL PLUGS ONLY.**

### **EVERY 1,000 MILES.**

Check, adjust and oil control cables, levers and twistgrip.

Check adjustment of rear chain. If rollers appear dry, oil with brush. In winter lubricate more frequently. If chain has collected much dirt remove, clean and grease.

Check adjustment of steering head bearings.

Oil front and rear brake pivot points, centre stand, etc.

Clean and re-oil carburetter air filter.

Clean carburetter union filter gauze.

Check and adjust contact breaker and sparking plug gaps.

### **EVERY 5,000 MILES.**

Drain and refill chaincase and gearbox, whilst engine is warm. **FILL TO LEVEL PLUGS.**

Make thorough examination of lighting cables.

Check front fork hydraulic damping. Top up with an oil can through oil level holes if necessary.

Grease speedometer gearbox. Take care not to over-grease as excess lubricant may reach the brake linings.

Check and if necessary dismantle, steering head and wheel bearings. Clean and pack with fresh grease.



# Front Fork

The telescopic fork consists of steering head and fork crown pressings to which are welded two stanchion tubes with fixed external phosphor bronze bushes, providing bearing surfaces for the sliding members.

Movement of each slider is controlled by a short tension spring encircling a  $\frac{3}{8}$ " dia. rod positioned in the centre of the slider. The lower end of the rod locates in a hole in the centre of the fork end where it is secured by a transverse anchor bolt engaging in a slot on the rod.

The top end of the spring is tapered and is retained on the rod shoulder by a washer and locknut. The lower coils of the spring are opened out to accept a slotted washer which bears against a shoulder in the stanchion tube and is held in position by a washer and circlip. Hence when the wheel and slider move upwards, the spring is extended in tension. Oil carried in the slider tube provides hydraulic damping on the compression stroke and also lubricates the sliding parts. As the fork is compressed, the slider moves up and oil cannot pass beyond the lower bushes. It is therefore forced through the annulus between the spring retaining washer and the rod, into the stanchion tube. A degree of rebound damping is obtained as a result of the partial vacuum which occurs as the fork re-assumes its static position. The capacity of each fork leg is 82.5 cc. or  $1\frac{1}{2}$  tank filler cap measures of SAE 20 oil. Grub screws at the mudguard bridge brackets enable the oil level to be checked.

**FRONT FORK MAINTENANCE.** New machines are supplied with the correct grade and quantity of oil. If a leak is suspected, the oil level grub screws (retaining mudguard bridge clips) must be removed. If oil level has dropped, top up with a few squirts from an oil can. In normal use we recommend checking the oil level every 5,000 miles.

**REMOVING FORK SLIDERS.** Raise the machine on the centre stand and place a wooden box or similar means of support under the front of the engine loop tube. Disconnect front brake cable at brake cam lever. Remove brake cable abutment bolt (complete with adjuster and cable) and R.H. mudguard bridge clip bolt. Next slacken wheel spindle cotter bolts, tapping the heads to release cotters. Unscrew spindle nuts and remove front wheel. Unscrew cotter bolts and remove mudguard complete with stays and bridge.

Slacken oil level grub screws two or three turns, then slacken the two rod anchor bolts at the bottom of the sliders, allowing the sliders to be pulled off the stanchion tubes and exposing the two rods.

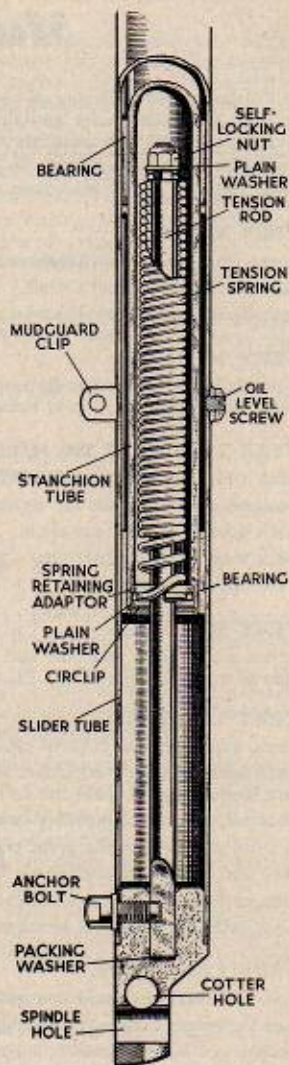

*Drawing by "The Motorcycle," London*

**DISMANTLING FORK RODS AND SPRINGS.** Removal of the sliders will reveal the circlips inside the stanchion tube extremities. The circlips should be carefully detached with thin nosed pliers and the complete rod and spring unit withdrawn.



# FRONT FORK COMPONENTS

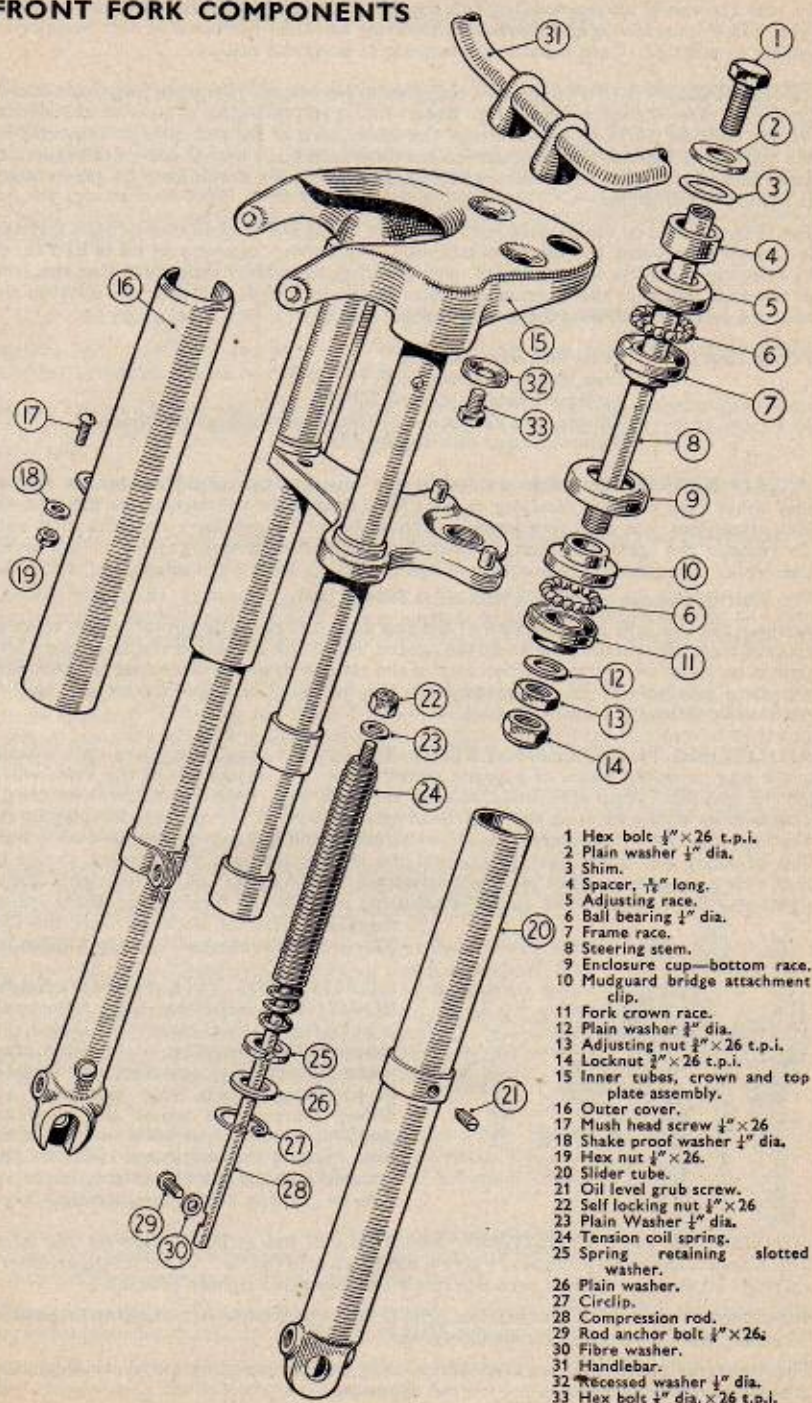

- 1 Hex bolt  $\frac{1}{2}$ "  $\times$  26 t.p.i.
- 2 Plain washer  $\frac{1}{2}$ " dia.
- 3 Shim.
- 4 Spacer,  $\frac{1}{8}$ " long.
- 5 Adjusting race.
- 6 Ball bearing  $\frac{1}{2}$ " dia.
- 7 Frame race.
- 8 Steering stem.
- 9 Enclosure cup—bottom race.
- 10 Mudguard bridge attachment clip.
- 11 Fork crown race.
- 12 Plain washer  $\frac{3}{8}$ " dia.
- 13 Adjusting nut  $\frac{1}{2}$ "  $\times$  26 t.p.i.
- 14 Locknut  $\frac{1}{2}$ "  $\times$  26 t.p.i.
- 15 Inner tubes, crown and top plate assembly.
- 16 Outer cover.
- 17 Mush head screw  $\frac{1}{2}$ "  $\times$  26
- 18 Shake proof washer  $\frac{1}{2}$ " dia.
- 19 Hex nut  $\frac{1}{2}$ "  $\times$  26.
- 20 Slider tube.
- 21 Oil level grub screw.
- 22 Self locking nut  $\frac{1}{2}$ "  $\times$  26
- 23 Plain Washer  $\frac{1}{2}$ " dia.
- 24 Tension coil spring.
- 25 Spring retaining slotted washer.
- 26 Plain washer.
- 27 Circlip.
- 28 Compression rod.
- 29 Rod anchor bolt  $\frac{1}{4}$ "  $\times$  26;
- 30 Fibre washer.
- 31 Handlebar.
- 32 Recessed washer  $\frac{1}{2}$ " dia.
- 33 Hex bolt  $\frac{1}{2}$ " dia.  $\times$  26 t.p.i.



To take the spring off the rod, the rod should be clamped in a vice (with lead or wood jaws) before unscrewing the locknut. The spring can then be removed with the slotted washer in position. Care should be taken not to bend the rod.

**RE-ASSEMBLING.** To fit the fork together again reverse the preceding instructions, bearing in mind the following details. Before fitting the spring on to the rod, the slotted washer must be placed in position over the lower turn of the coil spring. When fitting the rod and spring into the stanchion do not forget the plain washer and most important, make sure the circlip is really home and in its groove. There should be a  $\frac{3}{32}$ " gap between the ends of the Circlip.

The sliders should be replenished with oil before fitting and the rod anchor bolts screwed in loosely to prevent the oil from escaping. The correct quantity of oil is 82.5 cc. or  $1\frac{1}{2}$  filler cap measures in each slider. When fitting the sliders make sure that the ends of the rods locate in their respective holes in the fork ends and that the slots on the rods are in alignment with the anchor bolts.

**FORK DATA.** Total fork movement  $3\frac{1}{2}$ ".  
Free length of spring  $6\frac{1}{16}$ ".  
Maximum loading of fork 300 lbs.  
Oil capacity 82.5 cc. or  $1\frac{1}{2}$  filler cap measures per slider.  
Recommended oil viscosity SAE 20.

**WORN BEARINGS.** After a considerable mileage, the phosphor bronze bushes may show signs of wear resulting in poor fork action. As the bushes are fixed to the fork stanchions, the complete assembly should be exchanged for a reconditioned unit. To remove the fork stanchion, dismantle the sliders and spring units as previously described. Disconnect speedo cable and lighting cables. Remove headlamp and handlebar.

The steering column may be dismantled as follows:—

Remove the hex bolt in the centre of the top plate and partially withdraw the steering column from the bottom, allowing the spacer under the top plate and the upper fork race to be taken off. Further withdrawal of the column downwards enables the complete stanchion assembly to be separated from the frame. The outer covers are held in position by domed screws.

**ADJUSTING THE STEERING STEM.** The machine should be raised on the stand and a box or other means of support placed under the engine to lift the front wheel off the ground. With the hands holding the fork legs, need for adjustment can be detected by trying to rock the fork bearings. If there is any perceptible play in the bearings, use two 1" spanners to turn the adjusting and locknuts under the fork crown. The adjusting nut is the thin nut behind the thicker locknut. Adjustment should be such that no play may be felt yet the bearings are free to rotate and not too tight. When tightening the locknut make sure the adjusting nut and the locknut are firmly locked together. Test for slackness after the first 200 miles and subsequently every 1,000 miles.

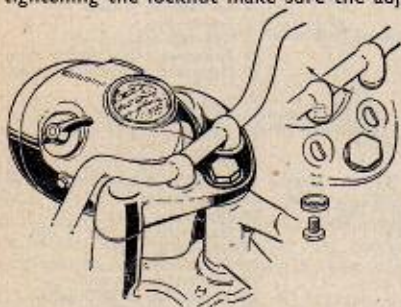

**ADJUSTING THE HANDLEBAR POSITION.** Handlebar angle adjustment is provided by two extensions with hemispherical bases locating in slotted concave recesses in the fork top plate and retained in position by two large hex bolts and dished spacers. To adjust the handlebar position, the two hex bolts under the top plate should be slackened with a plug spanner and the handlebar rotated to the desired position before retightening.

**ADJUSTING THE TWISTGRIP.** Adjustment of the spring tension on the twist-grip sleeve is effected by means of a screw and locknut in the bottom half of the twist-grip casting. To increase tension turn the screw clockwise and tighten locknut.

Adjustment should be such that the grip is easy to operate but remains in position when the hand is removed for signalling, etc.

The twistgrip should be removed periodically and the rotating sleeve smeared with grease to ensure a smooth action on the handlebar.



## TWIST-GRIP COMPONENTS.

- 1 Twistgrip rubber.
- 2 Clamp pin 1 BA.
- 3 Upper clip.
- 4 Rotating sleeve.
- 5 Lower clip.
- 6 Friction spring.
- 7 Adjusting pin 1 BA.
- 8 Adjusting pin locknut.
- 9 Cable slotted socket.
- 10 Throttle cable.

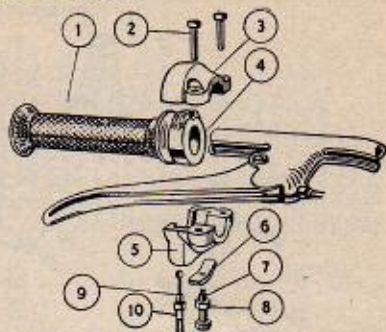

### ADJUSTING THROTTLE CABLE.

A certain amount of slack may develop in the throttle cable after a time; this can be taken up by means of the adjuster on top of the carburetter.

## Rear Suspension

**DESCRIPTION.** The rear wheel is mounted in a pressed steel fork pivoted within the centre section on rubber-steel torsion bushes. The bushes are spaced by a shouldered pivot tube and pressed into the ends of the fork torque tube. The fork is attached to the centre section by two  $\frac{1}{2}$ " bolts passing through the re-inforced pressing into the tapped ends of the pivot tube. Two barrel coil springs in compression form the suspension medium. Lugs welded to the top of the fork arms provide lower attachment points for the coil springs, which pass through rubber grommets in the centre section and are bolted to fixed lugs on the rear transverse member of the dorsal tube. Angularity of movement is taken up in the springs.

**REPLACING SPRINGS.** To remove the rear fork, raise the motor cycle on the stand, disconnect the rear chain and brake rod, slacken the spindle nuts, take out the rear wheel and remove the cushion seat, attached by six  $\frac{1}{4}$ " bolts (2 either side and 2 inside the rear mudguard). Next remove the two  $\frac{1}{2}$ " pivot bolts on the sides of the centre section and unscrew the uppermost spring retaining nuts.

Before attempting to remove the fork from the centre section, it is necessary to detach one of the springs by unscrewing the bottom hexagon. This will allow the fork to be withdrawn with one spring attached. The spring can be removed later.

To re-assemble the rear suspension, one of the new springs should be fitted to the fork and the second spring loosely attached to the upper fixing lug. With rubber grommets in position, the fork can be manipulated into the centre section to locate the first spring into its top fixing lug and to screw the second spring to its fork attachment lug. The pivot bolts can now be replaced. Before tightening the top spring retaining nuts make sure there is a  $\frac{1}{8}$ " gap between the adjusting nut (under upper lug) and spring stud nut (nearest top coil of spring).

### REAR SUSPENSION DATA.

Total rear fork movement at rear spindle  $3\frac{1}{4}$ ".

Load for spring in normal riding position 350 lb.

**MAINTENANCE.** No attention will normally be necessary. The rear suspension pivot bushes must NEVER be lubricated.

# FRAME AND REAR SUSPENSION COMPONENTS.

See key at foot of page 17.

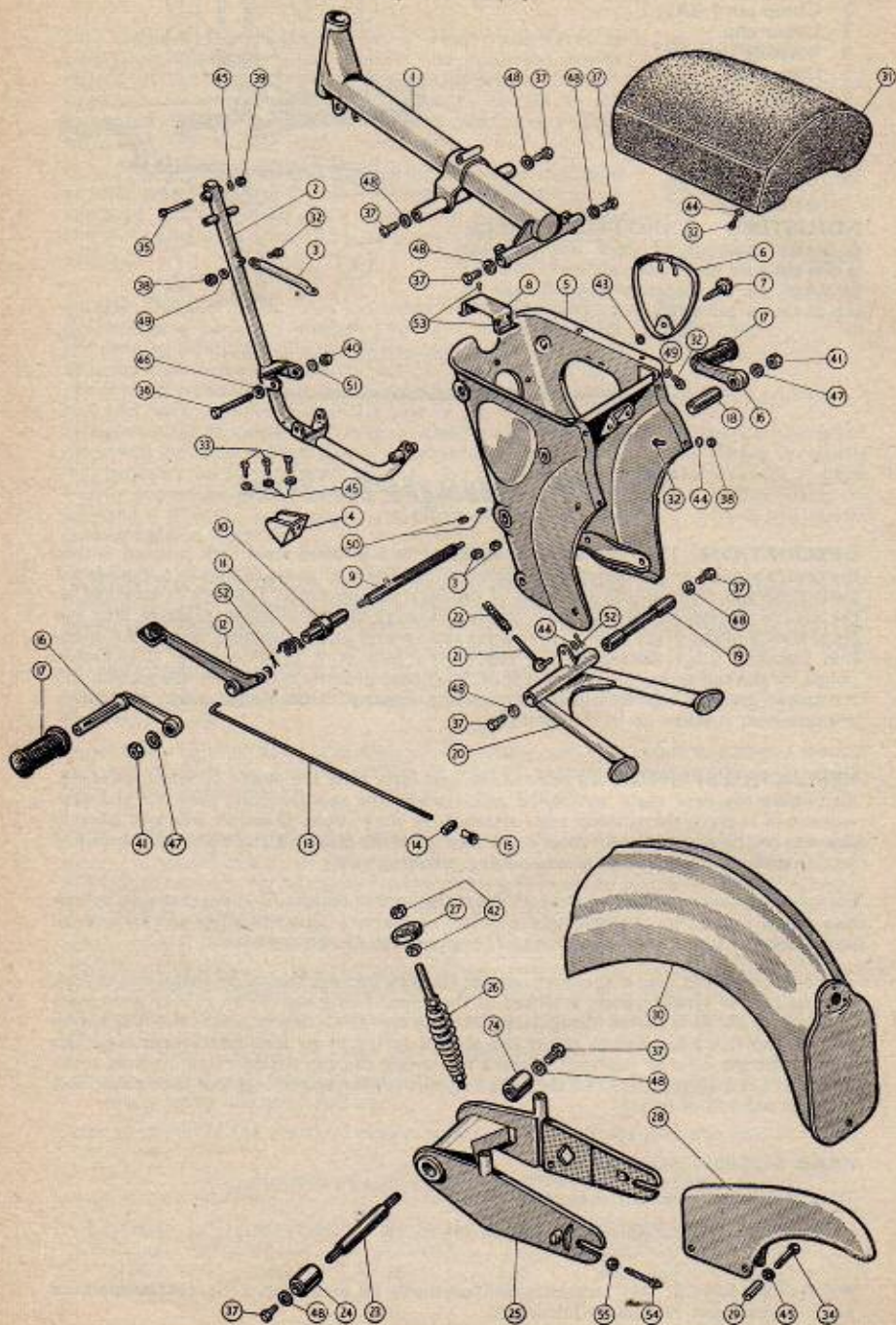



# Wheels and Brakes

**HUBS AND BEARINGS.** Both hubs are greased when new and no further lubrication will be required for several thousand miles. It is advisable to dismantle the hubs for examination of the bearings at approximately 5,000 miles. The old grease should be cleaned out with petrol or kerosene and the hubs packed with fresh grease before re-assembling. When dismantling and assembling the hubs refer to exploded drawings. If bearings or seals show any sign of wear, fit replacements. The need to exclude dirt from the bearings cannot be over emphasised.

## FRONT HUB BREAKDOWN.

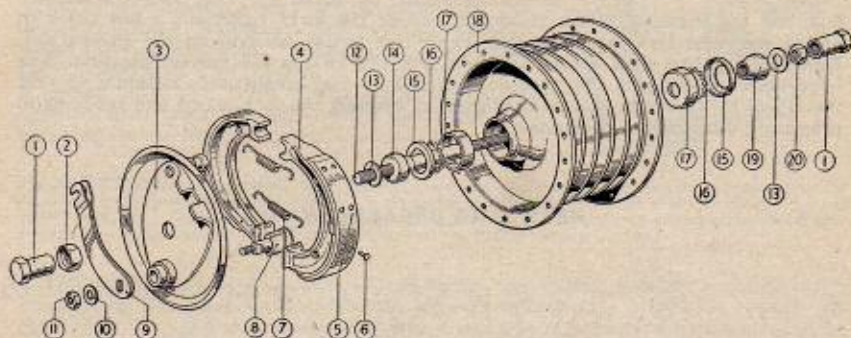

- |   |  |   |
|---|--|---|
| 1 Spindle nut $\frac{1}{2}$ " $\times$ 26.                          | 8 Brake cam.                                       | 14 Fixed cone.                              |
| 2 Recessed nut $\frac{1}{2}$ " $\times$ 26 $\times$ $\frac{1}{4}$ " | 9 Brake cam lever.                                 | 15 Dust cap.                                |
| 3 Brake backplate.  | 10 Brake cam special washer.                       | 16 Ball bearings $\frac{1}{2}$ ".           |
| 4 Brake shoe.   | 11 Hex nut $\frac{1}{2}$ " $\times$ 26.            | 17 Bearing cup.                             |
| 5 Brake lining.   | 12 Spindle.  | 18 Hub shell and brake drum.                |
| 6 Brake rivet.  | 13 Plain washer $\frac{3}{4}$ " $\times$ 16 s.w.g. | 19 Adjusting cone.                          |
| 7 Brake return spring.  | 13 Lock washer-adjusting cone.                     | 20 Hex locknut $\frac{1}{2}$ " $\times$ 26. |

**BRAKES.** Brake cable or rod adjustment should be such that only a slight movement of the lever or pedal is sufficient to operate the brake, but at the same time, the wheels must spin freely when the brakes are off. To obtain the correct adjustment, screw up the adjuster until the liners are just fouling the drum, then slack off two complete turns. Do not forget to reset the brake rod adjustment after adjusting the rear chain.

Never use oil to lubricate the bearings as it may spread to the brake lining surface and render the brakes ineffective.

**ADJUSTING FRONT WHEEL BEARINGS.** If play occurs in the front cup and cone bearings, take up as follows: Unscrew R.H. spindle nut and slacken the hex nut inside the fork end, next to the adjusting cone. Turn the adjusting cone clockwise until the wheel is free to rotate with no trace of lateral play and tighten the locknut.

Great care must be taken to ensure the bearings are not adjusted too tightly. After adjusting the front wheel bearings, make sure the locknut is tightened hard against the adjusting cone. Always use two spanners for the job to prevent the locknut from rotating the adjusting cone when it is tightened. There are ten  $\frac{1}{4}$ " balls each side (20 per wheel).

## KEY TO MAIN FRAME COMPONENTS.

- |                                    |   |                                    |
|------------------------------------|---|------------------------------------|
| 1 Frame dorsal tube.               | 10 Brake pedal spring housing and spacer. | 21 Stand operating rod.            |
| 2 Engine loop tube.                | 11 Return spring.                         | 22 Stand spring.                   |
| 3 Cylinder head steady tube (L15). | 12 Brake pedal.                           | 23 Rear suspension torque tube.    |
| 4 Rear engine lug.                 | 13 Brake rod.                             | 24 Rear suspension torsion bush.   |
| 5 Centre section pressing.         | 14 Brake lever roller.                    | 25 Rear suspension pivoting fork.  |
| 6 Toolbox lid.                     | 15 Brake rod adjuster.                    | 26 Rear suspension coil spring     |
| 7 Toolbox thumb screw.             | 16 Footrest hanger.                       | 27 Rear suspension rubber grommet. |
| 8 Battery bracket (L15).           | 17 Footrest rubber.                       | 28 Chainguard.                     |
| 9 Footrest brake pedal hex bar.    | 18 Footrest spacer R.H.                   | 29 Chainguard spacer.              |
|                                    | 19 Stand pivot tube.                      | 30 Mudguard and number plate.      |
|                                    | 20 Stand.                                 | 31 Cushion seat.                   |



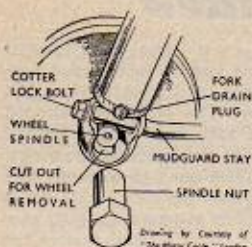

**REMOVING FRONT WHEEL.** To remove the front wheel raise the machine on the stand and place a wooden box under the frame loop tube to raise the front wheel off the ground. Disconnect the front brake cable. Slacken the mudguard stay cotter bolts three or four turns and tap head firmly to release cotter before removing the spindle nuts. The wheel can then be removed through the spindle cut outs in the fork ends. When replacing the wheel make sure the brake back plate anchor slot engages over the locating stud on the left fork leg and replace spindle nuts loosely. Tighten the left (brake side) spindle nut first, then tighten the right side spindle nut, after which the cotter bolt on the brake side should be locked up. Take away the wooden

box, roll the machine off the stand and bounce the forks vigorously a few times to enable the right fork leg to assume its correct lateral position on the spindle nut. Tightening up the right cotter bolt will lock the fork in the correct position. The importance of following this procedure cannot be over-emphasised, as failure to refit the wheel correctly may cause malalignment affecting the fork action and resulting in premature wear of fork components.

### REAR HUB BREAKDOWN.

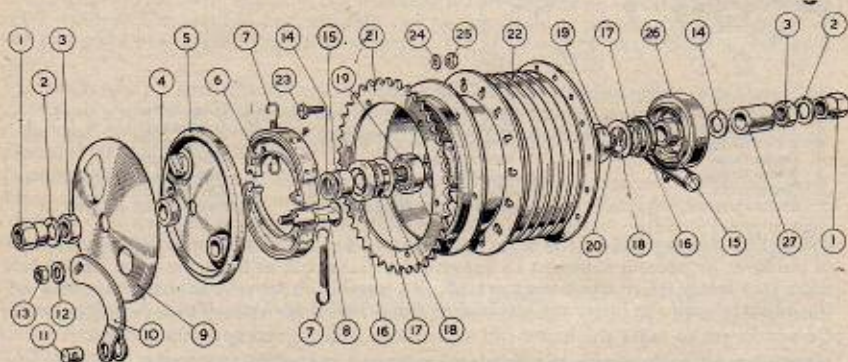

- |   |  |
|---|--|
| 1 Spindle nut $\frac{1}{2}$ " $\times$ 26.                | 15 Spacer $\frac{1}{8}$ " thick.                       |
| 2 Plain washer $\frac{1}{8}$ " $\times$ 10 swg.           | 16 Seal enclosure cup.                                 |
| 3 Locknut $\frac{1}{8}$ " $\times$ $\frac{1}{8}$ " thick. | 17 Felt seal.  |
| 4 Spacer L1 $\frac{3}{8}$ " thick.                        | 18 Seal enclosure washer.                              |
| 4 Spacer L15 $\frac{1}{2}$ " thick.                       | 19 Journal bearing 42 $\times$ 15 $\times$ 13 mm.      |
| 5 Brake back plate.                                       | 20 Spindle $\frac{1}{2}$ " dia.                        |
| 6 Brake shoe, lining and rivets.                          | 21 Chain sprocket L1—48 teeth for .305" chain roller.  |
| 7 Return spring.  | 21 Chain sprocket L15—48 teeth for .335" chain roller. |
| 8 Brake cam.  | 22 Hub shell.  |
| 9 Hub cover L15 only.                                     | 23 Hex bolt $\frac{1}{4}$ " $\times$ 26 t.p.i.         |
| 10 Brake cam lever.                                       | 24 Shakeproof washer.                                  |
| 11 Brake cam roller.                                      | 25 Hex nut.  |
| 12 Plain washer.  | 26 Speedometer gearbox                                 |
| 13 Hex nut $\frac{1}{8}$ " $\times$ 26 t.p.i.             | 27 Spacer $\frac{1}{8}$ " thick.                       |
| 14 Plain washer.  |  |

Speedometer drive gearbox is standard on L15 Cadet. Unless fitted as additional equipment, L1 Comet 100 models have no speedometer gearbox and are supplied with a 10 s.w.g. washer in its place.



**REMOVING REAR WHEEL.** Place machine on stand, disconnect chain, taking care not to let it trail on the ground, detach brake rod adjuster and speedo drive gland nut. Slacken both spindle nuts. The wheel can then be eased out. When replacing, make sure the back plate locking boss is engaged in its groove in the fork end. After replacing the rear wheel, remember to check: chain adjustment, rear brake adjustment and wheel alignment.

**CHECKING WHEEL ALIGNMENT.** It is wise to always check wheel alignment after removal. The simplest way is to use a thin piece of string stretched taut across both wheels with the front wheel pointing straight ahead. The string should just touch each tyre at both sides of the wheel centres.

An alternative method is to use a perfectly straight board placed alongside the wheels so that it touches each one. If necessary turn the handlebar so that the front wheel touches the board at two points. If both tyres do not make contact at two points, slacken the rear wheel spindle nuts and turn adjusters until wheel is correctly aligned.

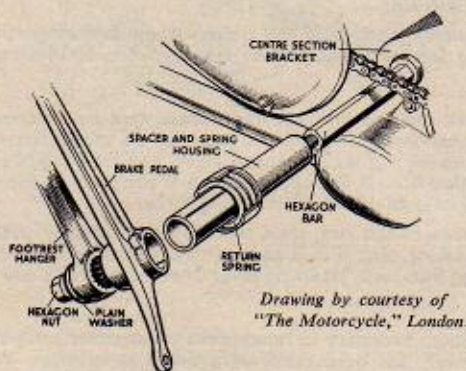

*Drawing by courtesy of  
"The Motorcycle," London.*

### ADJUSTING FOOTRESTS AND REAR BRAKE PEDAL.

The footrests are mounted on a hexagon bar passing through the centre section bracket. Serrations in the footrest hangers provide the method of adjustment. Tubular spacers are fitted over the hexagon bar, the L.H. spacer serving as the brake pedal pivot and carrying the return spring. To adjust the brake pedal position, it is only necessary to slacken the nut at the end of the L.H. footrest hanger and to rotate the pedal and spacer to the desired

position before tightening, thus locking the spacer between the centre section bracket and the footrest hanger. After re-setting the brake pedal, remember to re-adjust the rear brake rod by means of the knurled adjuster.

**SPEEDOMETER DRIVE.** If the speedometer drive has been removed do not forget to replace the distance piece behind it as if the engaging projections on the speedo drive are tight in the locations on the hub, the speedo drive will be damaged.

The speedometer cable has a knurled nut at the front where it joins the speedometer head and a hexagon to connect it to the rear wheel speedometer gearbox. The cable should be removed every 5,000 miles and lubricated to ensure complete freedom of movement for the inner driving cable. The speedometer head does not require any lubrication and should never be interfered with.

**REPLACEMENT SPOKES.** Spoke breakages rarely occur, but if foreign touring is envisaged it is a good plan to carry a few spare spokes. It is possible to replace a spoke without removing the tyre, but there is always a danger of the spoke protruding beyond the nipple into the well of the wheel and puncturing the rim tape and inner tube. We therefore advise owners to remove the tyre and have spokes fitted by a motor cycle repairer, who will grind off any surplus length. If fitted by the owner, the spokes should be filed or ground off flush with the end of the nipple in the well of the rim.

Size of Spokes : Comet 100 — front  $7\frac{1}{2}$ "  $\times$  12 swg. — nipples .225"  $\times$  12 swg.  
rear  $7\frac{1}{16}$ "  $\times$  10 swg. — nipples .225"  $\times$  10 swg.

Cadet 150 — front  $6\frac{3}{16}$ "  $\times$  12 swg. (N.S.)  
front 7"  $\times$  12 swg. (O.S.) — nipples .250"  $\times$  12 swg.  
rear  $6\frac{3}{16}$ "  $\times$  10 swg. — nipples .250"  $\times$  10 swg.



**TYRES.** To obtain the greatest mileage from your tyres and for the sake of your personal safety, the tyre pressures should be maintained at the recommended levels and checked once a week. Most garages have free air lines with pressure gauges, but a good pocket gauge will prove a useful investment.

When checking pressures, examine the outer covers and remove odd gravel chips wedged in the treads.

**RECOMMENDED TYRE PRESSURES :** Comet 100 Front 20 lbs. Rear 25 lbs.  
Cadet 150 Front 16 lbs. Rear 20 lbs.

If a passenger is carried on the Cadet 150, rear tyre pressure should be increased to 28—30 lbs.

The following hints will also assist in prolonging the life of the tyres :

Clean oil and grease from the tyres with petrol as soon as possible.

Ensure correct alignment of the wheels.

Cross tramlines at as near a right-angle as possible. They are dangerous, particularly in wet weather and may damage the tread.

Fierce braking and acceleration quickly wear away the tread. Apply brakes gently to avoid skidding, and when starting from rest, accelerate steadily on a small throttle opening.

**TYRE REMOVAL.** Remove valve cap and rim nut and deflate tyre by unscrewing the inner valve. A small key for unscrewing the valve is provided on top of the valve cap. Push outer-cover right into wheel rim well opposite valve, and insert tyre lever under cover as near the valve as possible. If the opposite side is properly in the well the edge of the cover should come over the rim without using force.

Work until the cover is off one side of the rim, then remove inner-tube by pushing valve up through hole and gently easing out. If it is desired to take the tyre right off, proceed in the same way — pushing into well, inserting lever in other side and working off.

**TYRE REPLACEMENT.** It is seldom necessary to remove the outer-cover completely with normal punctures, but if the tyre has been taken off proceed as follows : Work one side of tyre over rim, insert inner-tube and pump up sufficiently to remove any kinks ; place valve in hole and screw the securing nut about  $\frac{1}{2}$ " up the valve shaft. The white spot on the side of outer-cover should be positioned over valve.

Move free edge of cover over rim opposite valve and work round rim, ensuring that inner tube is not pinched, equally on either side of valve until a few inches remain free. The valve should be in the centre of this free length and no difficulty should be experienced in getting it over the edge of rim providing the rest of the cover is right down in the well.

Once tyre is home, inflate to about half pressure and manipulate cover until tread runs evenly ; when rotation of the wheel has shown this to be so, inflate to correct pressure. Do not forget to replace the valve cap. This keeps the dirt out.

When fitting new tyres it is a good plan to smear a little soft soap or petrol around the rim to ease the cover on.

---

## *Chains*

A chain is an assembly of links with rollers connected together by outer link plates and held together by rivets. If it is kept clean, adequately lubricated and correctly adjusted a chain will give little trouble and will wear out long before breaking point is reached.

The front chain is fully enclosed in an oil bath and consequently wear will be negligible over a long period. The rear chain, being exposed and more heavily loaded is more likely to give trouble through neglect and should be regularly checked for tension and frequently lubricated.

**REAR CHAIN ROLLER.** Fitted just behind the rear brake pedal to prevent chain rattle. Does not affect rear chain adjustment.



**ADJUSTING THE REAR CHAIN.** Correct rear chain adjustment is particularly important on motor cycles with pivoted fork rear suspension as movement of the rear wheel causes variations in the sprocket centres with resultant changes in chain tension. The rear chain should be adjusted after the first 200 miles and subsequently every 1,000 miles. Adjustment is obtained by moving the rear wheel forwards or backwards in the slotted fork ends which are fitted with adjusting bolts and locknuts to enable the wheel spindle to be set in the desired position. Since the rear chain tightens under load, correct chain adjustment must be maintained if the maximum useful life is to be obtained from the chain, sprockets and bearings.

To check and adjust rear chain tension, proceed as follows :

1. Raise the unladen machine on the stand and measure the amount of up and down movement on the bottom run of the chain midway between sprocket centres. The rear chain on Comet 100 and Cadet 150 models should have  $\frac{3}{4}$ " to 1" movement in this static position.
2. Retract the stand and sit on the machine. If there is no-one to help you, feel the bottom run of the chain by reaching down with the left hand. Chain whip should now be reduced to between  $\frac{3}{8}$ " and  $\frac{1}{2}$ " up and down movement. Check again in different positions by rolling the machine a little at a time. This is because chains seldom wear evenly and there is generally one spot tighter than the rest. Measurement should be made at the tightest point.
3. If chain whip is greater or smaller, slacken the rear spindle nuts and turn both adjusters until the correct chain tension is obtained. Tighten locknuts and spindle nuts and check again with the wheel in different positions. Always turn the adjusters an equal number of turns to ensure correct wheel adjustment.

**REMOVING AND REFITTING REAR CHAIN.** Obtain a piece of strong thin string about 10 feet long. Place the machine on the stand and turn the rear wheel until the connecting link is positioned near the rear sprocket and remove the connecting link. Pass the string through the hole of the end link on the top run and knot the two ends of the string together. Now pull the bottom run of the chain backwards with one hand while keeping the string taut with the other hand. As the end of the top run of the chain is disengaged from the gearbox sprocket, the string will lie one strand each side of the sprocket teeth. When the chain is well clear, cut one side of the string about 12" from where it is looped through the chain link.

The string should be left in position for refitting or replacing the chain. To refit, thread the longer end of the string through the hole in the end chain link and tie the two loose ends together. Then pull the string from the rear end at the same time guiding the chain to engage over the gearbox sprocket teeth. Keep on pulling until the chain encircles the rear wheel sprocket. Remove the string and refit the connecting link, making sure the closed end of the spring clip faces in the direction of rotation. To avoid the chain picking up any dirt or grit on the garage floor, it is advisable to lay some sheets of clean newspaper under the machine.

**CLEANING AND LUBRICATING THE CHAIN.** A chain cannot be cleaned merely by drenching with oil while in position on the machine.

The best way to do the job is as follows :

Remove spring clip and connecting link and take chain off the sprockets. Soak in a bath of \*paraffin using a stiff brush to remove all external dirt and allow \*paraffin to run through the joints of the chain. All grit and dirt between the joints must be removed. Swill in clean \*paraffin and hang over a pan to allow it to drain.

Immerse chain in tin containing graphited grease that has been heated until fluid over a pan of boiling water. Move the chain about in the grease until the grease has cooled off to normal semi-solid state. Remove chain from grease and wipe off surplus.

NOTE :—When replacing chain, see that the spring clip faces in direction of drive, i.e., closed end of link should face forwards on top run of chain.

**SHORTENING REAR CHAIN.** If chain has an even number of pitches, that is, a cranked link is not used in the chain, remove the rivets holding the second pair of outer link plates (see A) which will shorten the chain by four rollers and two pairs of outer link plates. Replace with cranked double link and single connecting link (B). \* Kerosene





If chain has an odd number of pitches, remove rivets holding the second pair of outer links (see A) (first pair will be cranked) and replace with single connecting link and inner link (B).

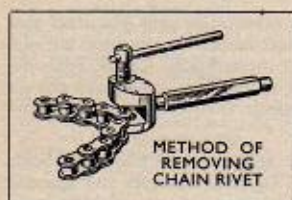

METHOD OF REMOVING CHAIN RIVET



METHOD OF REPLACING SPRING-CLIP

### CHAIN COMPONENTS



CRANKED DOUBLE LINK



CONNECTING LINK



INNER LINK

**FITTING A NEW REAR CHAIN.** To simplify the task of fitting a new rear chain, disconnect the old chain at the rear wheel sprocket by removing the single connecting spring link. Connect old chain to new chain, when by pulling the bottom run of the old chain, the new one can easily be carried round the gearbox sprocket, whereupon the old chain is disconnected and the ends of the new one connected together. Care should be taken when fitting a new chain to keep it from contact with the floor or any place where it is likely to collect grit, etc.

**REPLACEMENT CHAINS.** After considerable mileage, chains will require replacing owing to wear and stretch. These can be purchased either from your James dealer or from the factory.

#### Comet 100.

Primary chain : Renold No. 110037, 56 links,  $\frac{3}{8}$ " pitch,  $\frac{1}{4}$ " roller, .225" wide, pre-stretched.

Rear chain : Renold No. 112045, 122 links,  $\frac{1}{2}$ " pitch, .305" roller, .192" wide.

#### Cadet 150.

Primary chain : Renold No. 110038, 64 links,  $\frac{3}{8}$ " pitch,  $\frac{1}{4}$ " roller, .225" wide, pre-stretched.

Rear chain : Perry, 121 links,  $\frac{1}{2}$ " pitch, .335" roller, .205" wide.



# Engine and Gearbox

## Comet 100

98 cc. VILLIERS Mk. 4F.

*Exploded drawing reproduced by kind permission of "The Motorcycle," London*

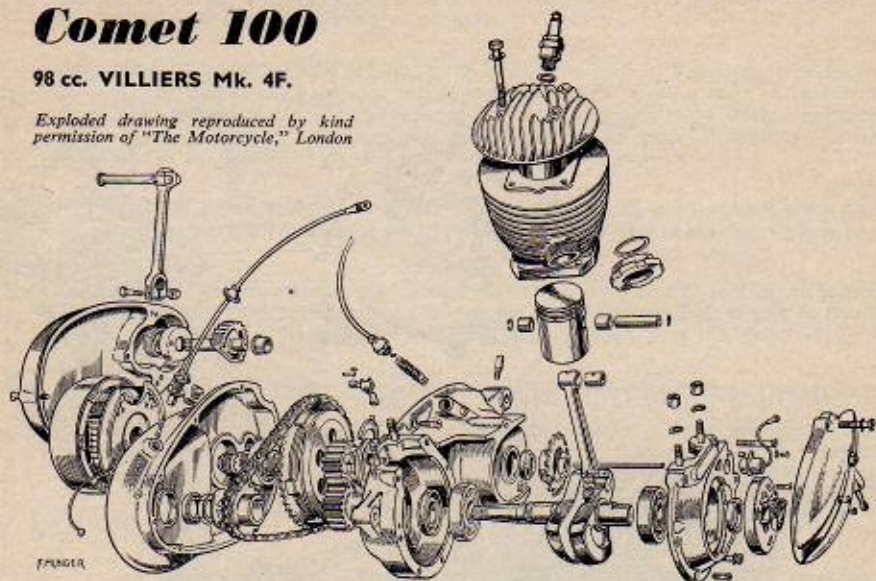

### DESCRIPTION.

**Crankcase and Gearbox.** This is an aluminium casting in three main parts, enclosing the two-speed gearbox and flywheel magneto. A detachable cover on the left-hand side of the engine encloses the contact breaker mechanism, which for ease of maintenance is located on the crankcase on the opposite side to the flywheel magneto.

**Cylinder.** A deeply finned cast iron cylinder is used, having one inlet, one exhaust, and two transfer ports. The cylinder is secured to the crankcase by four studs and nuts.

**Cylinder Head.** Secured to the cylinder by four bolts, the detachable aluminium alloy cylinder head is fitted with a Lodge type H14 14 mm. sparking plug.

**Piston and Connecting Rod.** The aluminium flat-topped piston carries two compression rings, and a special expander ring is fitted inside the lower ring to ensure proper compression when the engine is started from cold.

A floating gudgeon pin is fitted, and is located endwise by circlips. The connecting rod is a steel forging, having a plain bronze bearing at its small end, and at its big end, two rows of steel rollers running on the crankpin.

**Crankshaft.** This is a steel forging in two parts, rigidly joined together by the fitting of the crankpin. At each side, the crankshaft is carried in a large ball bearing which ensures free running and minimum wear. The contact breaker cam is formed on the end of the left-hand half of the crankshaft.

**Carburetter.** A Villiers Type S.12 carburetter is fitted on a stub cast integral with the cylinder barrel. Control of the carburetter is by twist grip. A choke lever is located on top of air filter housing. Closing the choke ensures easy starting from cold.

**Clutch.** The two-plate clutch has cork inserts, and is controlled by means of a cable connected to a lever on the left handlebar.

**Hand operated Two-speed Gear.** The two gears are engaged by means of a sliding dog mechanism, there being a neutral position between high and low gears. Control is by cable and a trigger lever on the right handlebar.

**Foot operated Two-speed Gear.** For information relating to this optional extra please turn to page 30.



ENGINE AND CONTACT-BREAKER COMPONENTS — COMET 100

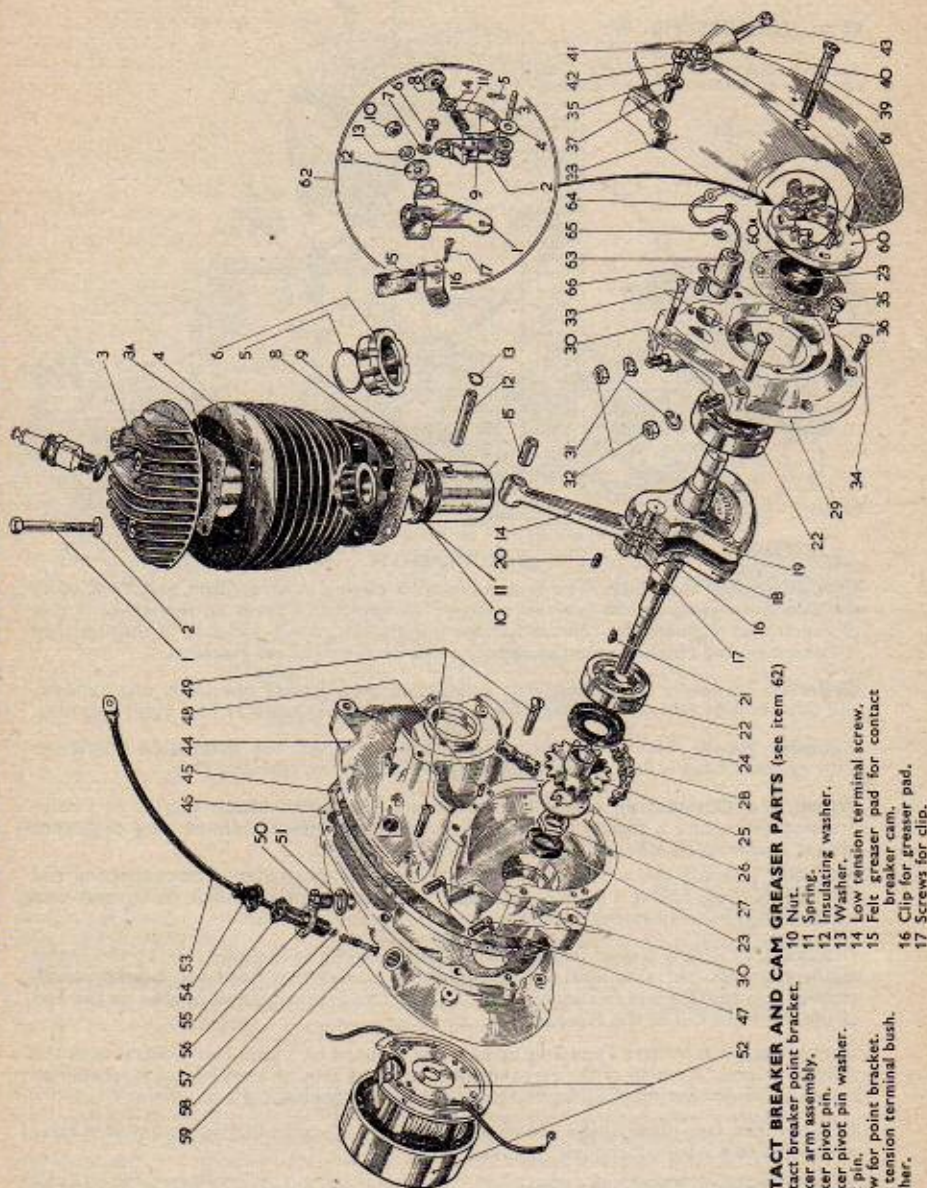

**CONTACT BREAKER AND CAM GREASER PARTS (see item 62)**

- 1 Contact breaker point bracket.
- 10 Nut.
- 2 Rocker arm assembly.
- 11 Spring.
- 3 Rocker pivot pin.
- 12 Insulating washer.
- 4 Rocker pivot pin washer.
- 13 Washer.
- 5 Split pin.
- 14 Low tension terminal screw.
- 6 Screw for point bracket.
- 15 Felt greaser pad for contact breaker cam.
- 7 Low tension terminal bush.
- 16 Clip for greaser pad.
- 8 Washer.
- 17 Screws for clip.



## COMET 100 ENGINE AND CONTACT BREAKER COMPONENTS.

- |                                |  |   |
|--------------------------------|--|---|
| 1 Cylinder head bolt.          | 28 Primary chain, 56 links, pre-stretched.     | 49 Screw securing clutchcase to gearcase.                                       |
| 2 Washer.                      | 29 Crankcase door.                             | 50 Oil filler plug.   |
| 3 Cylinder head.               | 30 Studs for cylinder base.                    | 51 Washer   |
| 4 Cylinder.                    | 31 Spring washer.                              | 52 Flywheel assembly complete with leads. (See separate drawing for components. |
| 5 Exhaust nut washer.          | 32 Nut.  | 53 High tension lead.   |
| 6 Exhaust nut washer.          | 33 Screw for crankcase door.                   | 54 Rubber cover for terminal holder.  |
| 8 Cylinder base gasket.        | 34 Screw for crankcase door.                   | 55 High tension terminal holder.  |
| 9 Piston complete with bushes  | 35 Crankcase drain plug and clutchbridge bolt. | 56 Felt washer.   |
| 10 Piston ring, standard size. | 36 Washer, drain screw.                        | 57 Brass terminal screw.  |
| 11 Expander ring.              | 37 Washer, plain.                              | 58 Brass terminal spring.   |
| 12 Gudgeon pin.                | 38 Cover, L.H. side.                           | 59 Terminal spring pad.   |
| 13 Circlip.                    | 39 Screw for cover.                            | 60 Adaptor for contact breaker.   |
| 14 Connecting rod.             | 40 Screw for cover.                            | 60A Adaptor sealing washer.   |
| 15 Small end bush.             | 41 Clutch lever adjusting screw.               | 61 Screw securing adaptor to crankcase door.                                    |
| 16 Rollers for crankpin.       | 42 Locknut.                                    | 62 Contact breaker assembly and cam lubricator. (See page 24 for components.    |
| 17 Crankpin.                   | 43 Clutch lever.                               | 63 Condenser.   |
| 18 Crankshaft, R.H.            | 44 Gearcase.                                   | 64 Screw securing condenser to crankcase door.                                  |
| 19 Crankshaft, L.H.            | 45 Clutchcase gasket.                          | 65 Washer.  |
| 20 Engine sprocket key.        | 46 Clutchcase.                                 | 66 Distance piece.  |
| 21 Flywheel key.               | 47 Dowels in gearcase and clutchcase.          |   |
| 22 Crankshaft ball bearing.    | 48 Dowel in gearcase for crankcase door.       |   |
| 23 Oil seal.                   |  |   |
| 24 Oil seal.                   |  |   |
| 25 Engine sprocket.            |  |   |
| 26 Lockwasher.                 |  |   |
| 27 Nut.                        |  |   |

## FLYWHEEL MAGNETO COMPONENTS — COMET 100

The six-pole magneto provides current for both ignition and lighting.

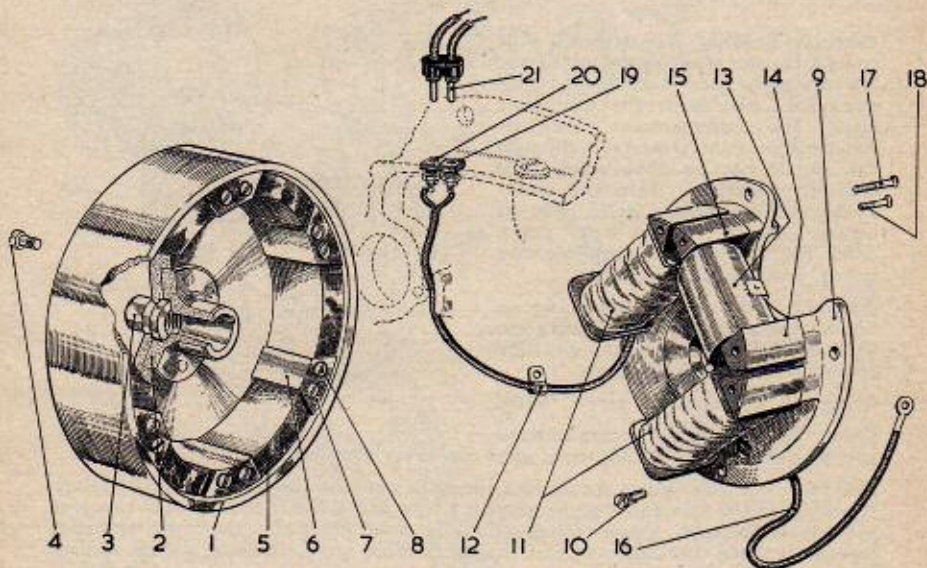

- |                            |   |  |
|----------------------------|---|--|
| 1 Flywheel.                | 10 Armature plate securing screws.                                      | 15 Ignition coil end, L.H.                           |
| 2 Flywheel centre.         | 11 Twin lighting coils complete with leads to sockets on engine casing. | 16 Low tension lead and shoe (rubber covered cable). |
| 3 Flywheel centre nut.     | 12 Clip securing lighting lead to armature plate.                       | 17 Screw for ignition and lighting coil ends.        |
| 4 Flywheel centre screws.  | 13 Ignition coil.   | 18 Screw for ignition coil ends.                     |
| 5 Flywheel magnets.        | 14 Ignition coil end, R.H.  | 19 Small socket for lighting lead.                   |
| 6 Flywheel pole pieces.    |   | 20 Large socket for lighting lead.                   |
| 7 Flywheel pole plates.    |   | 21 Twin plug for lighting lead.                      |
| 8 Flywheel pole screws.    |   |  |
| 9 Armature plate assembly. |   |  |



**Magneto Coils and Leads.** The ignition and lighting coils are carried on an armature plate secured to the engine clutchcase by four screws.

The high tension lead from the ignition coil to the sparking plug can be detached by unscrewing it from its socket on the top of the clutchcase.

When replacing it, be careful to ensure that the brass pad carried by the spring and secured to the terminal, makes contact with the soldered disc on the outside of the ignition coil.

The low tension lead from the ignition coil to the contact breaker passes through a passage-way provided in the gearcase and crankcase castings. At the ignition coil end it is soldered in place, and at the other end a shoe is fitted which is held in place by the low tension terminal screw. This screw also holds the condenser lead. If it is desired to remove the low tension lead from the engine, it must therefore be unsoldered from the ignition coil. If the coil and lead are to be taken out together, the shoe must be removed from the other end to allow the lead to pass through the castings.

The lighting leads are fastened to the lighting coils, and are led to two sockets on the clutchcase casting. If the leads have been taken out for any reason, they must be replaced so that they cannot touch the flywheel when the engine is running.

There is a clip on the armature plate, and a crevice in the clutchcase casting, and the lighting leads must be placed in these on re-assembly.

**Comet 100.**  
(Remove parts marked "B" for access to Flywheel).

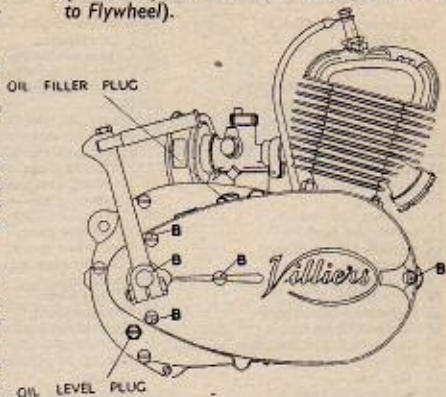

**Contact Breaker Adjustment.** The contact breaker assembly and condenser are secured to the left-hand side of the crankcase, underneath the detachable cover. The contact breaker points may require adjustments at intervals, although this should not be done unless it is definitely necessary. Turn the crankshaft until the moving point is in its highest position. With a feeler gauge, check the clearance between the two points, which should be .015".

If it is either more or less than this figure, slacken the screw "A" and move the bracket "B" in the required direction to obtain the correct clearance.

Re-tighten the securing screw firmly.

Check the clearance once more to make sure that the bracket did not move when the screw was tightened.

**NOTE:** The feeler gauge should be a sliding fit between the contact breaker points. Never adjust the points so that the gauge is a tight fit; if this is done, proper clearance will not be obtained. When replacing the side cover, check that the clutch operating lever is replaced correctly, and that the clutch cable has the correct amount of slack (see page 29).

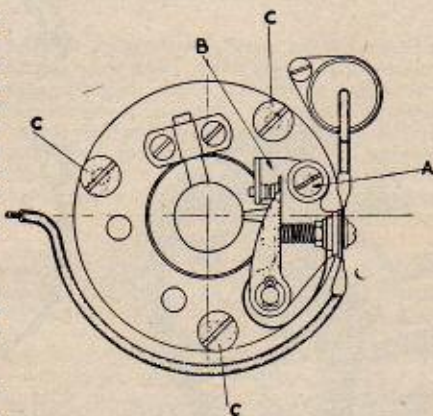

**Ignition Timing.** The contact breaker points should commence to open when the piston is  $\frac{1}{8}$ " before the top of its stroke.

To check the timing, remove the cover on the left-hand side of the engine to expose the contact breaker mechanism, and also remove the sparking plug so that the top of the piston can be seen when setting it in its correct position.



After setting the piston, examine the contact breaker points, which should just be commencing to open. If they have not done so, or have opened fully, the timing is wrong. Correct as follows: Slacken the three screws "C" which secure the complete contact breaker assembly to the crankcase, and move the assembly to the left or right according to the adjustment required.

Turning the contact breaker plate to the right, or clockwise, will advance the ignition timing, and turning to the left, or anti-clockwise, will retard the timing.

When satisfied with the adjustment, re-tighten screws "C."

**NOTE:** Always set the contact breaker points to their correct gap of .015" before timing the magneto.

### SERVICE DEPARTMENT

Our Service Department is open to callers as follows:

**MONDAY to FRIDAY ONLY :: Hours 8.30 a.m. — 12.30 p.m.  
1.30 p.m. — 5.30 p.m.**

IF REPAIRS ARE REQUIRED AN APPOINTMENT IS ESSENTIAL

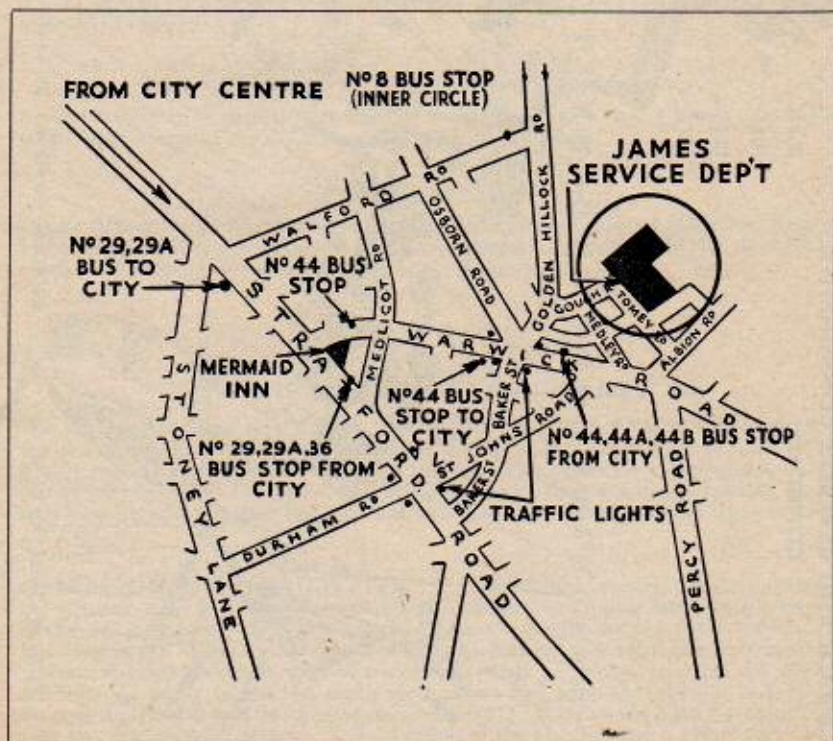



**CLUTCH AND GEARBOX COMPONENTS  
COMET 100**

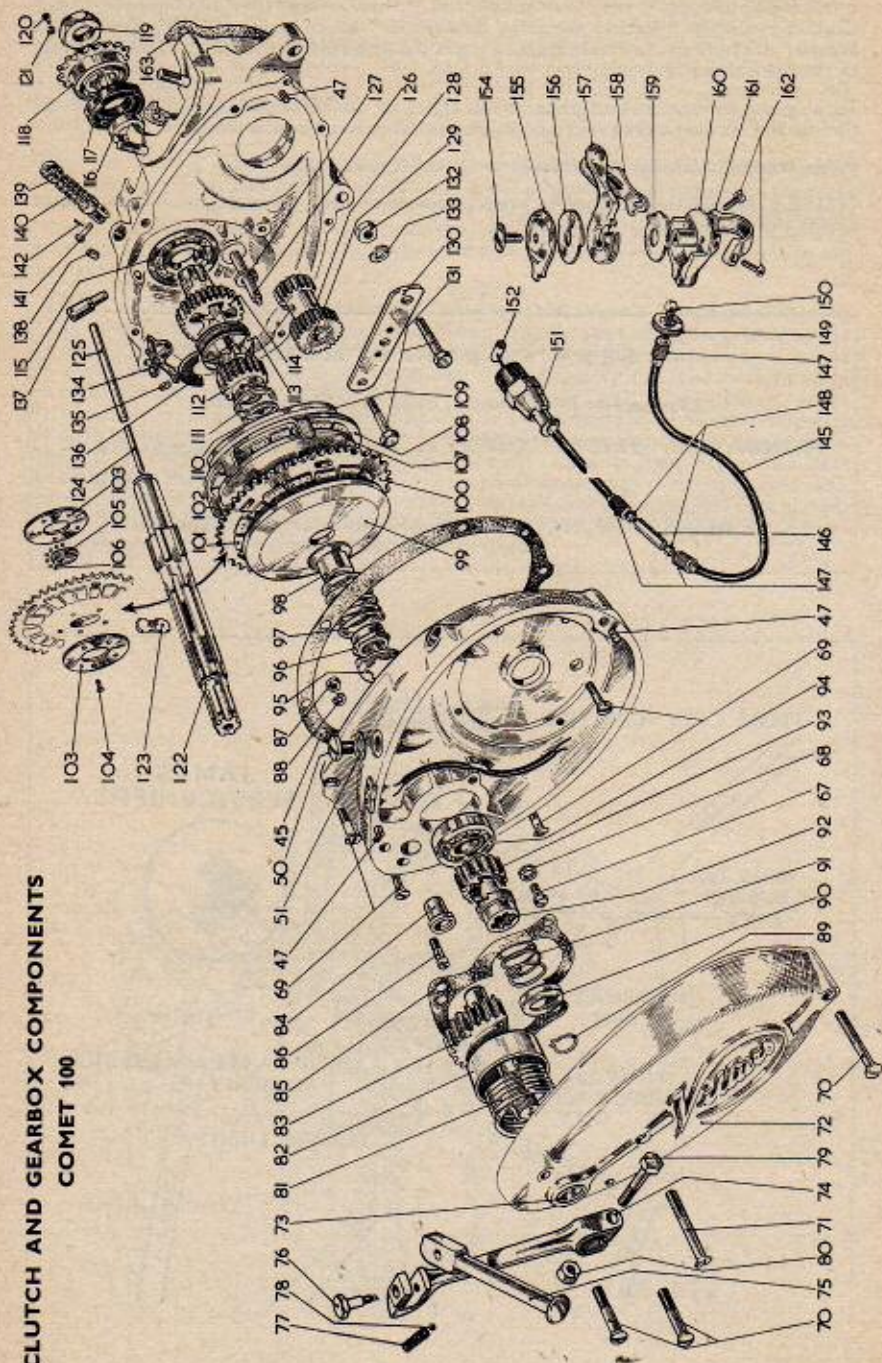



## COMET 100

### CLUTCH AND GEARBOX COMPONENTS.

- |  |   |   |
|--|---|---|
| 67 Oil level plug.                               | 99 Outer clutch plate, R.H.                                 | 132 Nut.                                |
| 68 Washer.                                       | 100 Clutch sprocket with cork inserts.                      | 133 Spring washer.                      |
| 69 Screws securing clutchcase to gearcase.       | 101 Large clutch cork for clutch sprocket and corked plate. | 134 Gear selector lever.                |
| 70 Screws securing flywheel cover to clutchcase. | 102 Small clutch cork for clutch sprocket only.             | 135 Pivot pin, selector.                |
| 71 Screw securing flywheel cover to clutchcase.  | 103 Side plate for clutch sprocket ball bearing.            | 136 Gear operating plate.               |
| 72 Flywheel cover.                               | 104 Rivets for plate.                                       | 137 Spindle for selector lever.         |
| 73 Bush for kickstarter shaft.                   | 105 Ball race.  | 138 Stop pin for selector lever.        |
| 74 Kickstarter lever.                            | 106 Ball.   | 139 Forked joint for gear selector.     |
| 75 Kickstarter pedal.                            | 107 Centre clutch plate, dished.                            | 140 Gear selector spring.               |
| 76 Kickstarter pedal pivot pin.                  | 108 Clutch plate, with cork inserts.                        | 141 Pin securing forked joint to lever. |
| 77 Kickstarter pedal spring.                     | 109 Outer clutch plate, L.H.                                | 142 Split pin for above.                |
| 78 Kickstarter pedal ball.                       | 110 Circlip.  | 163 Joint washer.                       |
| 79 Clamp bolt for kickstarter lever.             | 111 Splined washer, brass.                                  |   |
| 80 Nut.  | 112 Low gear wheel.   |   |
| 81 Kickstarter return spring.                    | 113 Sliding dog clutch.                                     |   |
| 82 Kickstarter return spring cover.              | 114 High gear wheel.  |   |
| 83 Kickstarter shaft.                            | 115 Ball bearing.   |   |
| 84 Bush in clutchcase for kickstarter shaft.     | 116 Distance piece.   |   |
| 85 Gasket, kickstarter cover.                    | 117 Oil seal.   |   |
| 86 Kickstarter stop pin.                         | 118 Driving sprocket.                                       |   |
| 87 Nut for stop pin.                             | 119 Retaining nut.  |   |
| 88 Spring washer.                                | 120 Locking screw for retaining nut.                        |   |
| 89 Circlip.                                      | 121 Spring washer.  |   |
| 90 Spring retaining washer.                      | 122 Clutch shaft.   |   |
| 91 Spring.                                       | 123 Clutch cotter.  |   |
| 92 Kickstarter ratchet.                          | 124 Clutch push rod, short.                                 |   |
| 93 Kickstarter pinion.                           | 125 Clutch push rod, long.                                  |   |
| 94 Ball bearing.                                 | 126 Countershaft spindle.                                   |   |
| 95 Splined lockwasher.                           | 127 Countershaft washer.                                    |   |
| 96 Clutch spring retaining nut.                  | 128 Countershaft bush.                                      |   |
| 97 Clutch spring.                                | 129 Countershaft bush.                                      |   |
| 98 Clutch spring locating bush.                  | 130 Countershaft bridge.                                    |   |
|  | 131 Countershaft bridge bolt.                               |   |

### HAND GEAR CONTROL LEVER ASSEMBLY.

- |                             |
|-----------------------------|
| 145 Cable.                  |
| 146 Cable adjusting sleeve. |
| 147 Cable adjusting screw.  |
| 148 Locknut.                |
| 149 Adjuster locknut.       |
| 150 Cable nipple.           |
| 151 Guide for forked joint. |
| 152 Cable nipple.           |
| 154 Screw.                  |
| 155 Top cover plate.        |
| 156 Top plate.              |
| 157 Control lever.          |
| 158 Trigger.                |
| 159 Ratchet plate.          |
| 160 Gear control body.      |
| 161 Clip.                   |
| 162 Screw.                  |

## ADJUSTING CLUTCH AND GEAR CABLE — COMET 100

It is very important that these two cables are kept properly adjusted, thereby preventing increased wear and tear and possible damage to internal parts.

**Clutch Lever.** The clutch lever should be adjusted, by means of the adjusting screw (see illustration) so that  $\frac{1}{16}$ " to  $\frac{1}{8}$ " movement between the lever and the cover is maintained. If the lever touches the cover, rapid wear of the clutch corks will occur.

When the engine is new, fairly frequent adjustments may be necessary owing to the "bedding down" of the clutch surfaces.

**Clutch Control Cable.** There should be a very small amount of slack in this cable when the clutch is engaged; about  $\frac{1}{8}$ " is sufficient. A cable adjuster is provided.

Insufficient slack movement in the clutch cable, or riding with one hand on the clutch lever, will cause the clutch to become slightly disengaged, resulting in its slipping instead of gripping firmly.

Always re-adjust the clutch cable after replacing the engine side cover, if this is removed to give access to the contact breaker, or when an adjustment to the clutch lever has been made.

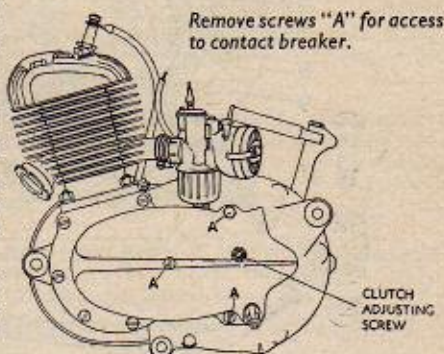



There must always be a slight amount of slack movement in the cable when the handlebar gear control lever is in the "HIGH" position,  $\frac{1}{16}$ " slackness being adequate; this ensures that the "HIGH" gear is fully engaged, a spring being used to retain the gears in "HIGH."

This cable has two adjusters, one about half-way between the control lever and the gearbox, and the other on the control lever itself. These will give a good range of adjustment.

The screw on top of the gear control lever must be kept tightened so that the lever is not loose, but has a smooth movement.

If the adjustments given above are correctly made, but low gear still jumps out of engagement, this indicates that the engine has been running with incorrect cable adjustments, thus damaging the gears.

**Gearbox Lubrication.** Remove the gearbox oil filler and oil level plugs (see engine diagram page 26). With the motorcycle on the stand, pour in recommended oil (SAE 140) until it starts to run out at the hole from which the oil level plug has been removed. Screw both plugs firmly into position.

### FOOTCHANGE GEARBOX — COMET 100

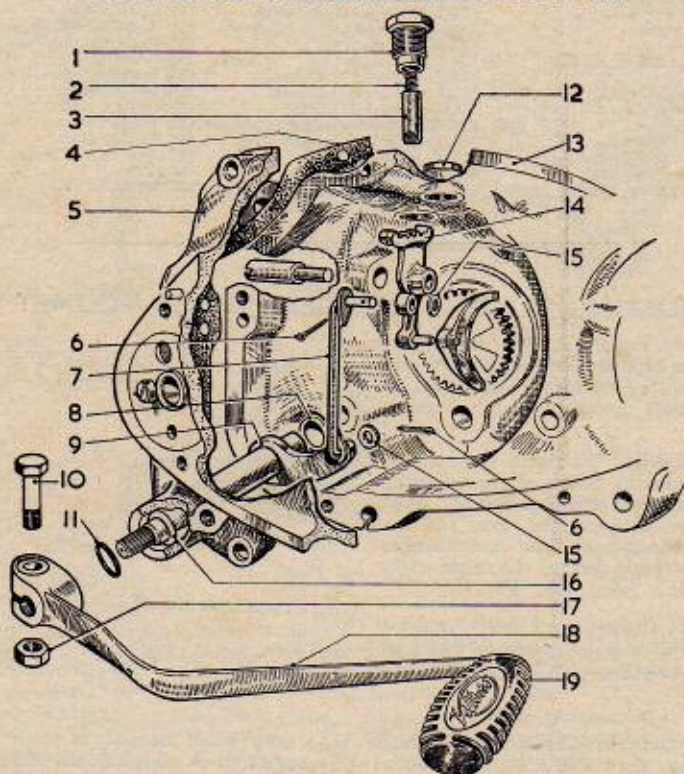

Footchange assembly — Mk. 6F engine.

Models with a footchange gear pedal have the Villiers Mk. 6F engine unit which differs in construction and is not interchangeable with the Mk. 4F with hand lever gear control.

The gear pedal is not of the positive stop pattern and has 3 positions: UP for low gear, DOWN for neutral and DOWN again for high gear.



Components which are illustrated but not listed are as for Mk. 4F engine (see pages 24 to 29).

- |                            |                               |                             |
|----------------------------|-------------------------------|-----------------------------|
| 1 Plunger box.             | 8 Inner bush for pedal shaft. | 14 Gear selector lever.     |
| 2 Plunger spring.          | 9 Pedal shaft assembly.       | 15 Washer for link rod.     |
| 3 Plunger.                 | 10 Hex bolt for pedal.        | 16 Outer bush, pedal shaft. |
| 4 Clutchcase joint washer. | 11 Sealing ring.              | 17 Hex nut for pedal.       |
| 5 Outer casing.            | 12 Gearcase plug.             | 18 Gear pedal.              |
| 6 Split pin.               | 13 Inner casing.              | 19 Rubber cover.            |
| 7 Link rod assembly.       |                               |                             |

## *Carburettors*

### TYPE S12 CARBURETTER—COMET 100

**Description.** In the Villiers Type S12 carburetter fitted to Comet 100 models, the float chamber and float surround the needle jet block, the float rising as the fuel enters the chamber until the correct level is reached. At this point a forked lever which rests on top of the float, lifts a fuel needle valve to stop the fuel supply. Fuel enters the needle jet block from the calibrated jet fitted in the bottom of the float chamber. The throttle is of a cylindrical pattern, and is fitted with a tapered needle which extends below it into the centrepiece. When the throttle, closes the air supply, the largest diameter of the needle nearly closes the fuel outlet; but when the throttle is raised to admit more air, the smallest diameter of the needle allows more fuel to pass.

In this way the combination of jet size, needle position and needle taper gives a correct mixture of fuel and air at all throttle settings. The S12 carburetter incorporates an air by-pass screw which enables the mixture to be adjusted between closed and  $\frac{1}{2}$  throttle. Screw in to richen mixture and vice versa.

It is not possible to give a standard position for this needle in relation to the throttle, because each engine requires an individual adjustment.

It is not normally necessary to alter the setting of the needle, which has been determined during testing at the works. This setting controls the mixture strength from the point at which the engine is ticking over until the throttle is about two-thirds open. After this the jet controls the mixture up to full throttle position.

**DISMANTLING THE CARBURETTER.** It is recommended that as long as the carburetter — or any other part of the engine — is giving satisfactory service, it should not be tampered with or taken to pieces. If dismantling becomes necessary, proceed as follows:

**To remove Throttle from Body.** Open throttle fully and remove the top cap screw. Withdraw throttle, taking care not to damage the taper needle. The throttle may be removed from the cable after releasing the tension on the throttle spring and lifting cable nipple from the slot in the throttle slide. The taper needle can be removed after the spring clip has been moved to one side.

**To remove Jet Block and Fuel Needle from Body.** A special tool is required to remove the jet block, which is screwed into the carburetter body. Unless the jet is worn, it is recommended that this component is not disturbed.

Removal of the fuel needle and the fuel needle bush is possible after the float cup, float and fuel needle lever have been removed.

The fuel needle bush is screwed into the carburetter body and again it is recommended that this remains undisturbed unless a replacement is required.

**To remove Tickler.** A circlip retains the tickler in position, and, after removal, the tickler and tickler spring can be withdrawn from the carburetter body.

**To remove Main and Air Compensating Jets.** These are screwed into the float cup and carburetter body respectively. The jets may be unscrewed for cleaning when necessary. Providing the air filter is kept in position, the air compensating jet should not require cleaning.



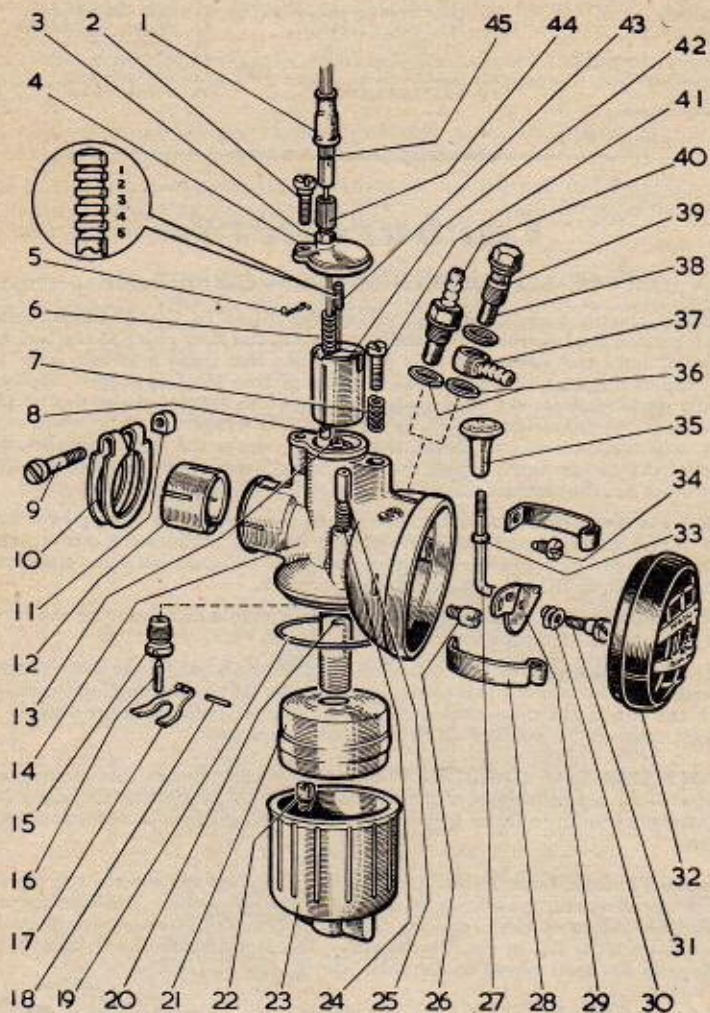

- |                                    |                                  |                               |
|------------------------------------|----------------------------------|-------------------------------|
| 1 Cable cover.                     | 16 Fuel needle.                  | 31 Strangler plate screw.     |
| 2 Top cap screw.                   | 17 Fuel needle lever.            | 32 Filter assembly.           |
| 3 Cable adjuster locking nut.      | 18 Fuel needle lever hinge pin.  | 33 Strangler spindle seal.    |
| 4 Carburettor top cap.             | 19 Float chamber sealing washer. | 34 Screw.                     |
| 5 Needle locating circlip.         | 20 Tickler circlip.              | 34 Self-tapping screw.        |
| 6 Throttle spring.                 | 21 Float.                        | 35 Strangler spindle knob.    |
| 7 Air adjusting screw spring.      | 22 Main jet.                     | 36 Fibre washer.              |
| 8 Throttle end cable nipple.       | 23 Float chamber.                | 37 Banjo union (for item 39). |
| 9 Carburettor body clip bolt.      | 24 Tickler spring.               | 38 Filter gauze.              |
| 10 Carburettor body clip.          | 25 Tickler.                      | 39 Banjo bolt.                |
| 11 Carburettor body clip bolt nut. | 26 Air compensating jet.         | 40 Petrol feed union.         |
| 12 Heat insulating bush.           | 27 Strangler spindle.            | 41 Air by-pass screw.         |
| 13 Needle jet block.               | 28 Filter clip.                  | 42 Throttle.                  |
| 14 1/2" choke carburettor body.    | 29 Strangler plate.              | 43 Taper needle.              |
| 15 Fuel bush.                      | 30 Strangler screw washer.       | 44 Cable adjuster.            |



**Re-assembly of Carburetter.** This is the reverse of the process already described but the following points should be observed :—

The fuel needle bush, main and air compensating jets must be screwed firmly into their respective positions. The fuel needle must be inserted, point first, into the fuel needle bush, and the fuel lever located by the needle hinge.

With the float in position, ensure that it is clear of the tickler. If not, the fuel needle lever has been bent, and must be reset to give a vertical measurement of  $\frac{3}{32}$ " between the top of the float and the face of the carburetter body where the sealing ring is located.

The float chamber sealing washer must be intact and seated correctly in the recess in the carburetter body.

Replace float chamber and **tighten by hand. Do not use spanner, etc., otherwise damage to threads may occur.**

Replace taper needle in throttle, locating by spring clip in the correct groove, and replace throttle spring and cable.

Place throttle into carburetter body, guiding the taper needle into the jet block. Replace top cap and knurled screw.

**Re-setting Carburetter.** The main, air compensating and needle jets, and the taper needle, fitted to each carburetter have been selected to give optimum results, for each particular engine, and, therefore, it is recommended that adjustments to the taper needle setting and air by-pass screw only are carried out by the owner.

The air by-pass screw enables the mixture to be adjusted between the closed and  $\frac{1}{4}$  open position of the throttle. Screw in to richen mixture and vice-versa.

The taper needle position governs the mixture strength between  $\frac{1}{4}$  and  $\frac{3}{4}$  throttle. The nominal position is with the needle locating clip in groove No. 3. Groove No. 1 is the weakest position. The speed of tickover can be adjusted by the cable adjusting screw. In cold weather, the taper needle may be set one groove richer (one number higher) than standard.

#### **CARBURETTER CABLE ADJUSTMENT.**

A certain amount of slack may develop in the throttle cable after a time ; this can be taken up by means of the adjuster on top of the carburetter.

#### **AIR CLEANER.**

The air cleaner should be removed for cleaning approximately every 2,000 miles. Remove by releasing clips dip the cleaner in petrol and after drying, immerse in thin oil and hang up to drain before refitting to carburetter.

---

#### **TYPE S.19 CARBURETTER — CADET 150**

The Carburetter fitted to the Cadet 150 is the Villiers Type S.19. In this carburetter the position of taper needle in relation to the throttle is adjustable by means of the grub screw situated in centre at top of throttle. This adjustment is provided to suit individual engines, and it should not be necessary to alter the makers setting except after considerable mileage. The standard setting from throttle to end of taper needle is 2.015 ins.

**OPERATION OF CARBURETTER.** The handlebar twistgrip control operates the throttle slide and thereby regulates the amount of mixture entering the engine, whilst the carburetter itself automatically meters and atomises the correct amount of fuel to give the necessary mixture strength. To achieve this automatic control of the mixture strength, two separate fuel systems are fitted, namely the main-jet and pilot-jet systems. At idling speeds the carburetter draws fuel from the pilot-jet and, as the throttle is gradually opened, the fuel is then drawn in turn from the pilot " progression " hole and the main-jet system. The operation of the two systems is given overleaf :—



**1(a) Pilot-Jet System.** At idling speeds, when the throttle is nearly closed, the pilot outlet hole (A) is subject to the very high engine suction, and petrol is, therefore, drawn from the float chamber through the pilot tube (B) and the pilot outlet hole. The calibrated pilot-jet is contained in the top of the pilot tube. At the same time, a filtered supply of air is drawn from the mouth of the carburettor through passage (C) through the variable air-jet (D) and is then pre-mixed with petrol in the small chamber (E). The pilot adjuster screw (F) varies the size of the pilot air jet, and therefore, the pilot mixture strength — to richen mixture, turn screw clockwise.

When the throttle slide is opened a small amount beyond that required for idling, the suction on the pilot outlet hole is reduced, but at the same time, the suction on the pilot "progression" hole (G) increases. A further supply of petrol is, therefore, drawn through the "progression" hole, and prevents the weak spot which would otherwise occur due to the fall off in supply from the pilot hole before the main jet comes into full operation.

It follows from the preceding remarks that whenever the throttle is shut off whilst the engine speed is high (such as on long downhill sections) the pilot system is subject to the full engine suction, and petrol will flow into the engine from the pilot outlet hole. As the engine is not firing under these conditions, this fuel supply will tend to build up in the crankcase and cylinder and cause severe "four-stroking" or "eight-stroking" when the throttle is opened again. To overcome this fault an automatic air bleed to the pilot has been incorporated, which relies upon the matching of two slots, one in the throttle slide and the other in the carburettor body. When the throttle slide is shut, two slots line up and air can flow from the front of the carburettor through the throttle slide and down passages H and J into the pilot system. The high depression on the pilot system is then destroyed. In all other throttle positions, the two slots do not line up, and no air can pass to the pilot system through these passages.

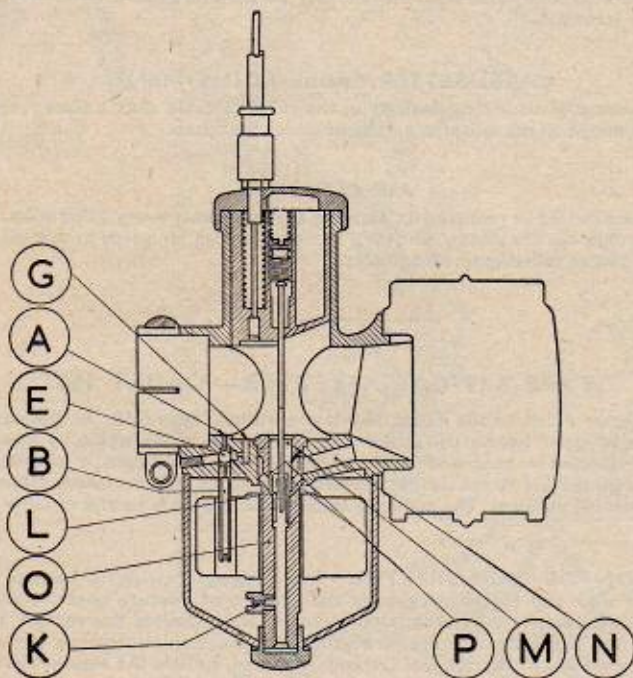



CARBURETTOR COMPONENTS — CADET 150.

Villiers Type S.19.

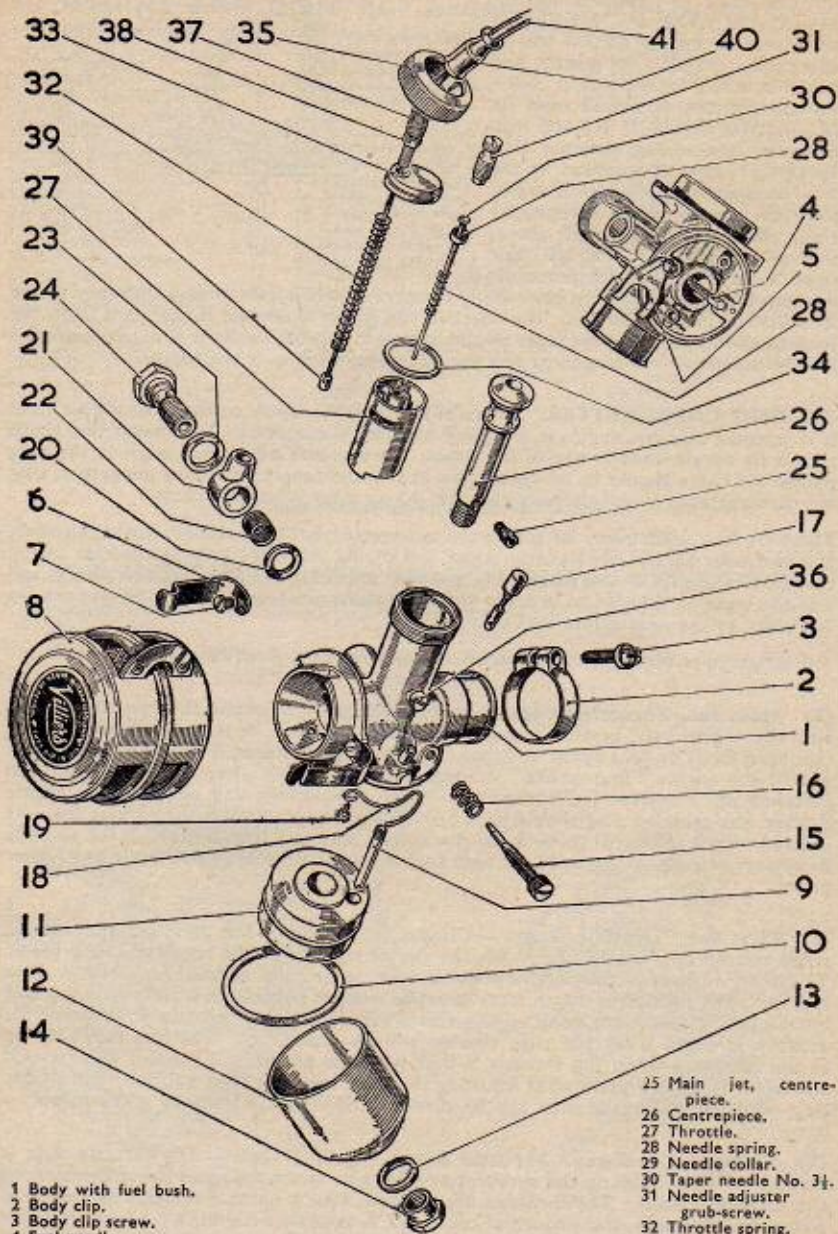

- 1 Body with fuel bush.
- 2 Body clip.
- 3 Body clip screw.
- 4 Fuel needle.
- 5 Fuel needle lever.
- 6 Air filter clip.
- 7 Screw for clip.
- 8 Air filter.
- 9 Pilot jet.
- 10 Cup joint washer.
- 11 Float.
- 12 Float cup.

- 13 Bottom nut washer.
- 14 Bottom nut.
- 15 Pilot jet needle.
- 16 Spring for needle.
- 17 Tickler.
- 18 Tickler spring.

- 19 Screw for spring.
- 20 Washer, small hole.
- 21 Banjo union.
- 22 Filter gauze.
- 23 Washer, large hole.
- 24 Banjo bolt.

- 25 Main jet, centre-piece.
- 26 Centrepiece.
- 27 Throttle.
- 28 Needle spring.
- 29 Needle collar.
- 30 Taper needle No. 3½.
- 31 Needle adjuster grub-screw.
- 32 Throttle spring.
- 33 Top disc.
- 34 Top disc washer.
- 35 Top ring.
- 36 Throttle guide screw.
- 37 Cable adjuster.
- 38 Adjuster locknut.
- 39 Cable nipple.
- 40 Cable cover.
- 41 Throttle cable.



**1(b) Main-Jet System.** As the throttle slide is opened further beyond the idling and progression positions, the engine suction has its effect upon the main-jet system, and petrol is drawn from the float chamber through the calibrated main jet (K) and the needle-jet (L) and into the small pre-mixing chamber (M). There the petrol is atomised by the filtered secondary air which is drawn from the mouth of the carburettor along passage (N) and which enters the centrepiece (O) through four small holes (P). The rich petrol-air mixture then flows from the pre-mixing chamber into the main mixing chamber, where it meets the main air stream. The effective size of the needle-jet (L) depends upon the throttle slide position (as the taper needle is fixed to the slide) and the sizes of the needle-jet and the needle are chosen to give correct carburation over the range.

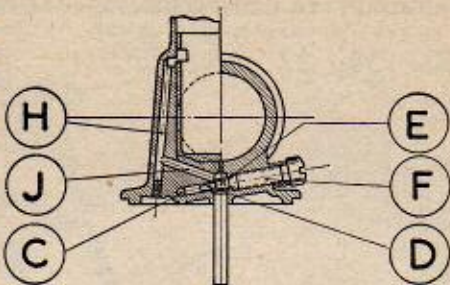

**TUNING CARBURETTER.** Before any attempt is made to tune the carburettor it is essential that the engine is in a good mechanical condition. This means that there should be no air leaks at any of the joints, there should be a good spark at the plug points and there should be no restriction in the fuel supply. It is also important, that the carburettor is clean internally and that the air filter is not obstructed.

There are four adjustments for tuning the carburettor, but each of these has its full effect at a particular part of the throttle range, and should therefore only be used for tuning that particular part of the range. There is also a definite sequence for the tuning, and this also must be adhered to in order that the results achieved with one adjustment are not upset by the next adjustment.

The sequence of tuning with the necessary adjustments is given below :—

**(2) Main Jet. Throttle Range— $\frac{3}{4}$  to Full.** In order to obtain the correct main jet size, the engine must be tested at full throttle in top gear. If the engine lacks power, detonates badly or runs better with the strangler slightly closed, a larger jet is required. Should the engine "four-stroke" or improve momentarily after the petrol has been switched off, a smaller jet is required. After de-clutching and stopping the engine quickly, the sparking plug should have a shiny black appearance if the correct main-jet is fitted. As an additional guide the engine should tend to "four-stroke" at full throttle in bottom gear on level ground (or high engine speeds in neutral) but not in any higher gears.

**(2) Pilot Jet. Throttle Range—Closed to  $\frac{1}{2}$  Open.** The pilot jet must be set when the machine is stationary with the engine running at the required idling speed. To richen mixture, screw in the pilot adjuster screw, and to weaken, unscrew pilot adjuster. The mixture strength must be set as weak as possible consistent with a steady reliable idling speed and good engine acceleration from this throttle position. If the mixture strength is set too rich, trouble will be experienced with the fuel build-up in the crankcase when the throttle is shut with the engine still running fast. Should this latter fault be present after adjusting the pilot, unscrew pilot a further half a turn. Any weakness on acceleration can be cured by throttle cut away as given below :—

**(3) Throttle Cut-Away. Throttle Range— $\frac{1}{4}$  to  $\frac{1}{2}$  Open.** The throttle slide is made with a cut-away on the carburettor inlet side which influences the depression on the main-jet system. The throttles are marked with a number which represents, in sixteenths of an inch, the amount of cut-away. A throttle with more cut-away will give weaker mixtures (over the particular throttle range) and vice-versa. If the acceleration is weak, fit throttle with smaller cut-away. Should the engine tend to "four-stroke" when the throttle is shut, fit a larger cut-away.

**(4) Needle Adjustment. Throttle Range— $\frac{1}{4}$  to  $\frac{3}{4}$  Open.** The needle is adjusted by the grub screw in the top of the throttle—screw down to weaken mixture, and



vice-versa. The needle controls the mixture strength over most of the "cruising range" and must be correct for good fuel consumption and acceleration. After carrying out the above adjustments, it is wise to go back and re-check the pilot adjustment to see that this has not been affected by other adjustments.

**CHANGING THE TAPER NEEDLE.** Remove throttle from body after unscrewing the top ring, and in the centre at top of throttle will be found a small slotted grub screw. This is the adjuster referred to in the previous paragraph, and when it is removed by unscrewing, the needle with spring can be pushed up from underneath. When replacing the needle make sure that the needle collar is in position.

**REMOVING FUEL NEEDLE.** If it is necessary to remove the fuel needle the first step is to remove the bottom nut and fibre washer which enables the float chamber to be taken off.

To detach the float the main jet (K) must be unscrewed from the side of the centrepiece. The forked lever which is interposed between the fuel needle and float is split to enable it to be pulled clear of its retaining pin. After this has been done the fuel needle will drop away.

#### **DO NOT REMOVE THE CENTREPIECE FROM THE CARBURETTER BODY.**

The carburetter has a banjo petrol pipe fitting inside of which is a fine mesh filter gauze which should be periodically cleaned by dipping in petrol. Be sure that when replacing the petrol pipe the fibre washers make a petrol tight joint, otherwise fuel will be wasted. The air filter should be cleaned every 2,000 miles by washing in petrol. Following this the filter should be dipped in thin oil and allowed to drain before refitting.

#### **RE-ASSEMBLING CARBURETTER.**

Clean the various components and make sure that the tickler vent hole is clear. Insert the fuel needle and refit the forked fuel needle lever. Place float in position, this is marked "top," and replace main jet in side of centrepiece. Clean out the float cup and replace with large fibre joint washer at top. Replace bottom nut and fibre washer but do not use too much force, otherwise there is the danger of stripping the thread of centrepiece. Replace throttle in body at the same time guiding the taper needle into hole in top of centrepiece. A guide screw in the carburetter body will prevent the throttle being replaced unless it is correctly positioned. Locate top disc in top of body and screw on top ring. If the carburetter has been removed from the engine, make sure when re-fitting that the body is pushed on to the manifold as far as possible, and that it is set upright. There are four narrow slots in the body to allow the securing clip to function, and if the manifold stub does not extend past the end of the slots, air will be sucked in causing hard starting and erratic running.



# Engine - Cadet 150

147 cc. Villiers Mark 30C.

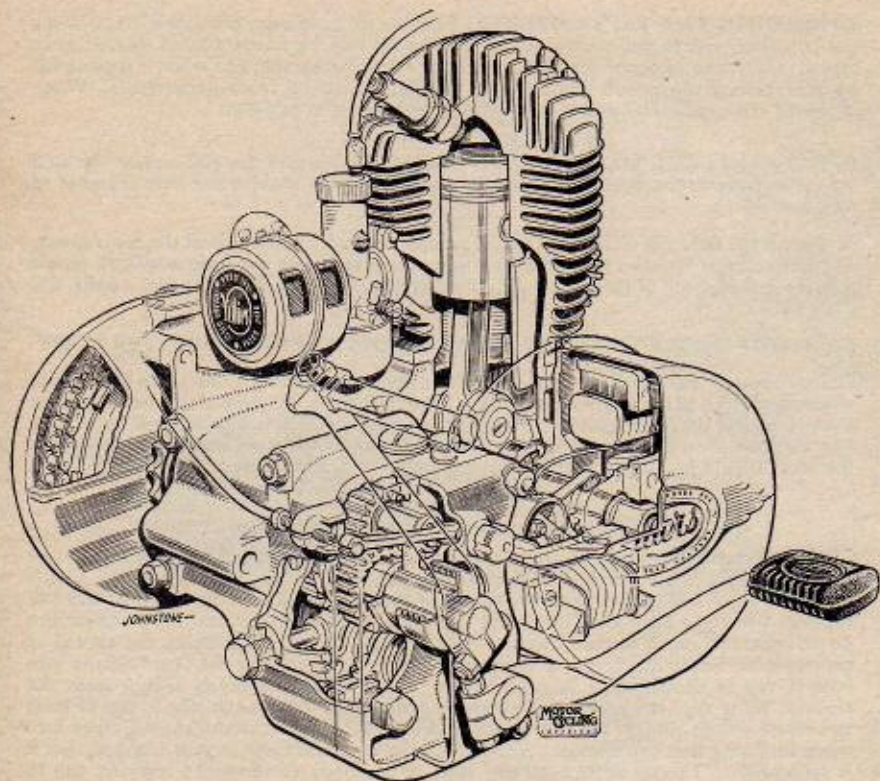

*Drawing reproduced by kind permission of "Motor Cycling"*

The Villiers Mark 30C two-stroke engine fitted to the Cadet 150 is a highly efficient power unit which, provided it is thoughtfully maintained and lubricated, will give years of service without requiring any major replacements. By virtue of its simplicity, it is cheap and easy to maintain and even owners with no previous motor cycling experience can confidently tackle normal adjustments, maintenance and minor repairs. In the case of major repairs, should they ever arise, we strongly advise the amateur mechanic to entrust the job to a qualified motor cycle repairer or ourselves.

**DESCRIPTION.** In the cylinder walls are arranged four holes or ports, viz.: one inlet port which permits the air fuel mixture to enter the crankcase, two transfer ports which, through passages in the sides of the cylinder, are in communication with the crankcase, and one exhaust port through which the burned charge is allowed to escape. Movement of the piston in a vertical direction is arranged to cover and uncover the ports at suitable times so that the mixture is first drawn from the carburettor through the inlet port into the crankcase. There it is compressed and then forced through the transfer passage into the cylinder above the piston, where it is further compressed. It is then ignited by a spark from the plug, and after expansion due to heat, escapes through the exhaust port into the exhaust pipe and silencer.



# CADET 150—ENGINE COMPONENTS.

See key on page 40

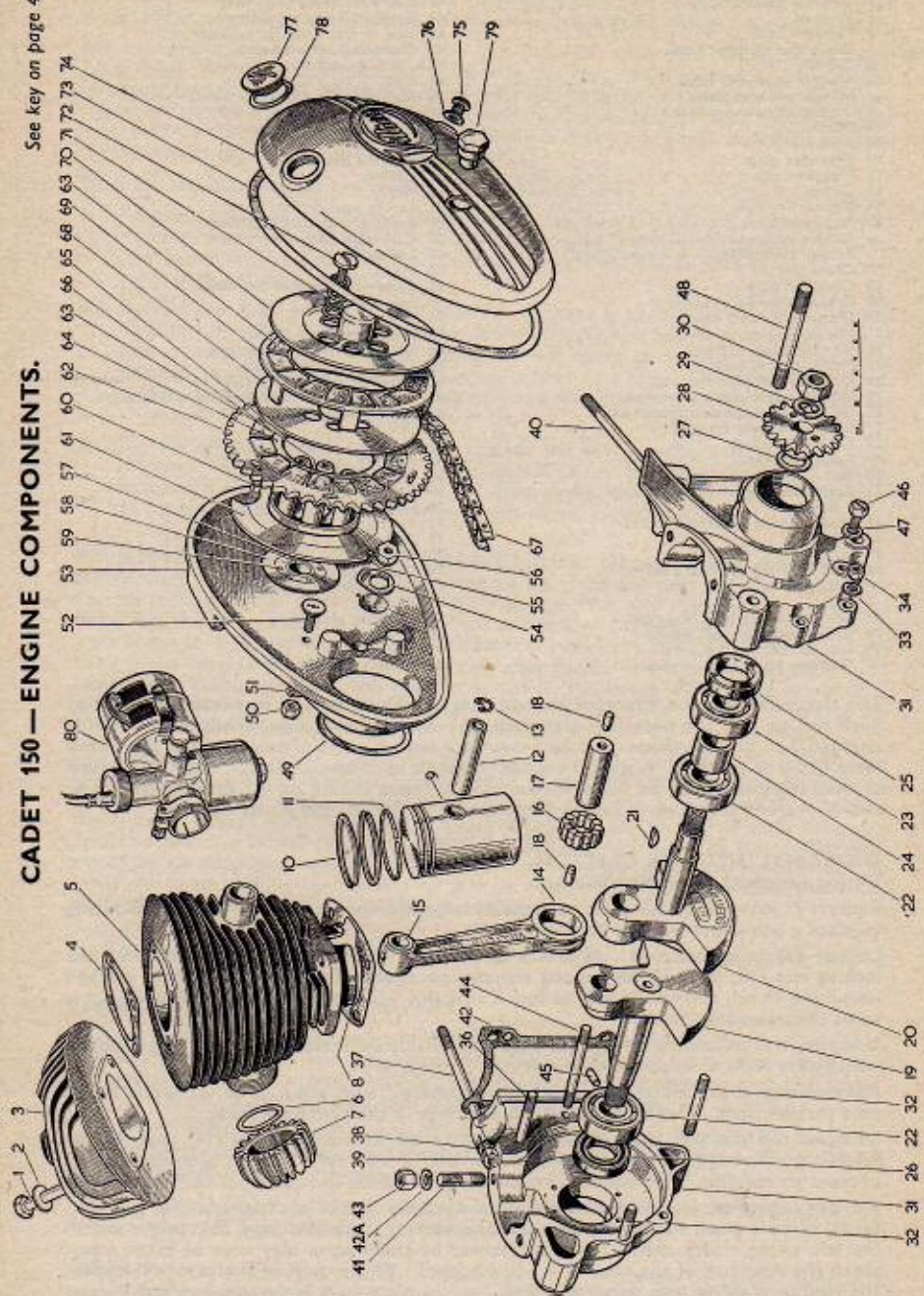



## ENGINE BREAKDOWN — CADET 150

- |   |  |
|---|--|
| <ul style="list-style-type: none"> <li>1 Cylinder head bolt.</li> <li>2 Washer.</li> <li>3 Cylinder head.</li> <li>4 Gasket for cylinder head.</li> <li>5 Cylinder.</li> <li>6 Washer—cylinder head.</li> <li>7 Nut for exhaust pipe.</li> <li>8 Gasket for cylinder base.</li> <li>9 Piston.</li> <li>10 Piston ring.</li> <li>11 Expander ring.</li> <li>12 Gudgeon pin.</li> <li>13 Circlip.</li> <li>14 Connecting rod.</li> <li>15 Small end bush.</li> <li>16 Rollers for crankpin—12 steel <math>\frac{1}{4}'' \times \frac{1}{4}''</math>.</li> <li>Rollers for crankpin—6 bronze <math>\frac{1}{4}'' \times \frac{1}{4}''</math>.</li> <li>17 Crankpin.</li> <li>18 Crankpin plug.</li> <li>19 Crankshaft—Right hand.</li> <li>20 Crankshaft—Left hand.</li> <li>21 Key for engine sprocket.</li> <li>22 Mainshaft ball bearing.</li> <li>23 Mainshaft ball bearing.</li> <li>24 Distance piece for bearings.</li> <li>25 Oil seal—crankshaft drive end.</li> <li>26 Oil seal—crankshaft magneto end.</li> <li>27 Shim for engine sprocket.</li> <li>28 Engine sprocket.</li> <li>29 Spring washer.</li> <li>30 Nut.</li> <li>31 Crankcase, right and left hand halves, less fittings.</li> <li>32 Stud securing crankcase halves.</li> <li>33 Washer.</li> <li>34 Nut.</li> <li>36 Stud securing crankcase halves.</li> <li>— Washer.</li> <li>— Nut.</li> <li>37 Gearbox fixing stud, top right.</li> <li>38 Gearbox fixing stud, washer.</li> <li>39 Gearbox fixing stud, nut.</li> <li>— Gearbox fixing stud, medium.</li> </ul> | <ul style="list-style-type: none"> <li>40 Gearbox fixing stud, long.</li> <li>— Gearbox fixing stud, short.</li> <li>41 Stud in crankcase for cylinder.</li> <li>42 Gearbox joint washer.</li> <li>42A Spring washer.</li> <li>43 Nut.</li> <li>44 Stud securing crankcase halves—short.</li> <li>45 Crankcase dowel.</li> <li>46 Crankcase drain plug.</li> <li>47 Washer.</li> <li>48 Stud for chaincase.</li> <li>49 Gasket.</li> <li>50 Nut.</li> <li>51 Spring washer.</li> <li>52 Breather valve for chaincase.</li> <li>53 Chaincase, inner, with gland plate.</li> <li>54 Locking plate.</li> <li>55 Screw.</li> <li>56 Cone nut for inner chaincase.</li> <li>57 Felt washer.</li> <li>58 Gland plate.</li> <li>59 Rivets for gland plate.</li> <li>60 Dowels for outer chaincase.</li> <li>61 Clutch centre assembly.</li> <li>62 Clutch sprocket assembly.</li> <li>63 Cork for clutch sprocket and corked plate.</li> <li>64 Ball retaining plate.</li> <li>65 Ball.</li> <li>66 Rivet.</li> <li>67 Primary chain.</li> <li>68 Centre plate.</li> <li>69 Corked plate.</li> <li>70 Front plate assembly</li> <li>71 Spring.</li> <li>72 Screw.</li> <li>73 Gasket.</li> <li>74 Chaincase, outer.</li> <li>75 Chaincase, oil level screw.</li> <li>76 Washer.</li> <li>77 Oil filler plug.</li> <li>78 Washer.</li> <li>79 Domed nut.</li> <li>80 Carburetter.</li> </ul> |
|---|--|

The clutch requires no attention beyond that of lubrication and correct adjustment of push rod to give the necessary clearance to prevent clutch slip. Whilst the clutch is engaged, i.e., driving, there must be a clearance between end of push rod and the clutch lever fitted to gearbox. A special adjuster having a knurled and slotted head is provided so that adjustment can be made without tools. There should be  $\frac{1}{16}''$  free movement at end of gearbox clutch lever before commencing to depress the clutch springs.

**DISMANTLING THE CLUTCH.** To strip the clutch and to gain access to the driving sprockets proceed as follows :

Remove primary chaincase cover retained by large domed nut (79, page 39), remembering to place a pan underneath to receive the oil.

Loosen engine sprocket (11, page 41) by placing "hammer tight" spanner over the locking nut (30, page 39) and giving the spanner a sharp blow with the hand gripped round the clutch springs. It will be found that this will loosen the nut sufficiently for it to be unscrewed by hand.

Unscrew the six clutch springs (2, page 41), withdraw metal plates and intermediate cork-insert plate to expose clutch sprocket (7, page 41).

Remove engine and clutch sprockets simultaneously with chain. The former is keyed on a parallel shaft. There are 50  $\frac{3}{16}''$  ball bearings in the clutch sprocket.

Unscrew the nut (12, page 41) holding the clutch centre assembly (14, page 41) by inserting a strong screwdriver between shafts of assembly in such a manner as to prevent its rotation. The assembly is splined on the shaft and no key is therefore fitted.

Remove engine sprocket key, unscrew nut and washer at back of chaincase, over gearbox. Next, remove small screw (55, page 39) and locking plate (54, page 39), below and to the left of the clutch shaft. The nut retained by these parts may now be taken away, when the rear half of the chaincase will be freed. Withdrawal of the case will expose the countershaft or final drive sprocket, held in place by a large thin nut and locking screw. (When re-assembling do not forget to replace the latter and also the engine sprocket key and locking plate).



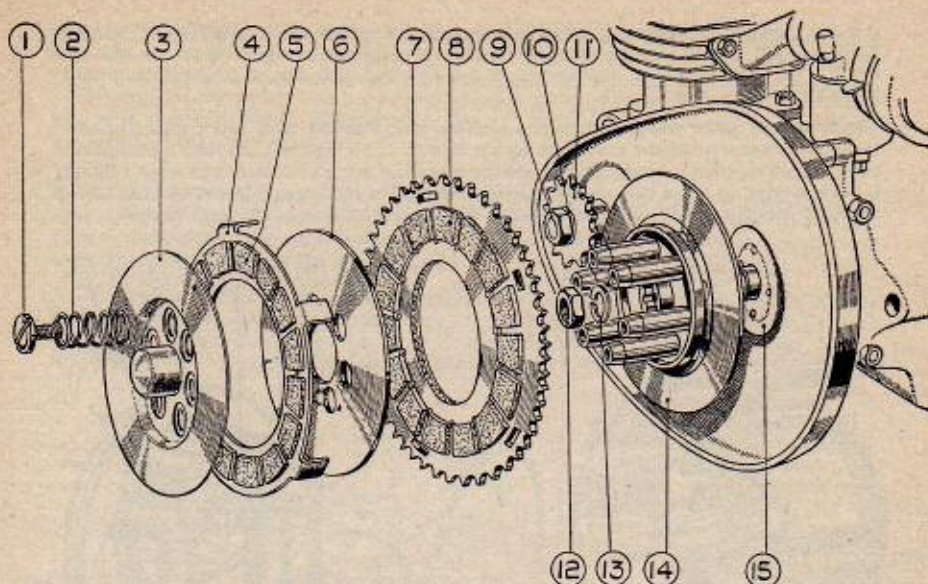

- 1 Clutch spring screw.
- 2 Clutch spring.
- 3 Chaincase gland plate.
- 4 Clutch plate—corked.
- 5 Cork insets.
- 6 Clutch centre plate.
- 7 Clutch sprocket assembly.
- 8 Cork insets.

- 9 Engine sprocket nut.
- 10 Engine sprocket shim.
- 11 Engine sprocket.
- 12 Mainshaft nut.
- 13 Mainshaft spring washer.
- 14 Clutch centre assembly.
- 15 Oil seal.

When removing the final drive sprocket do not take off the rear chain ; apply the rear brake so that the sprocket is tightly held by the chain. The same will apply when replacing the sprocket and tightening the nut.

Reverse the order of removal when rebuilding.

**LUBRICATING GEARBOX AND PRIMARY CHAINCASE.** Always specify one of the recommended makes and grades of oil. Do not overfill either the gearbox or the chaincase, excessive lubricant can cause nearly as much trouble as the lack of it. A dipstick is provided on the gearbox and the level should be checked as often as possible. When refilling remove the level plug (item 22, page 45) at the back of the gearbox and fill until oil runs out of the plug-hole.

Similarly, on the chaincase, oil should be at plug-hole (item 75, page 39) level when the machine is on an even surface.

## FLYWHEEL MAGNETO — CADET 150

The purpose of the high tension magneto is to produce a hot spark across the points of the sparking plug. A magneto consists principally of permanent magnets, a high tension coil, a contact breaker and a condenser. In this magneto the magnets are secured to the rotating flywheel, and the high tension coil, contact breaker and condenser are stationary.

The flywheel magneto has six poles and provides current for both ignition and lighting. The same magneto is used for both DIRECT and RECTIFIER-BATTERY lighting sets although wiring connections differ and references should be made to the wiring diagrams.



If it is necessary to remove the flywheel magneto, a special "Hammer Tight" spanner (see page 43) should be used on the centre nut exposed on removal of the flywheel cover. The centre nut is imprisoned in the flywheel and acts as an extractor when turned anti-clockwise.

The armature plate which carries the ignition coil, lighting coils and contact breaker assembly is secured to the crankcase by six screws. The high tension lead from ignition coil to sparking plug is detachable by unscrewing from armature plate, and when refitting it is important to make sure that the brass carried by the spring and secured to the terminal makes contact with the soldered disc on the outside of the ignition coil.

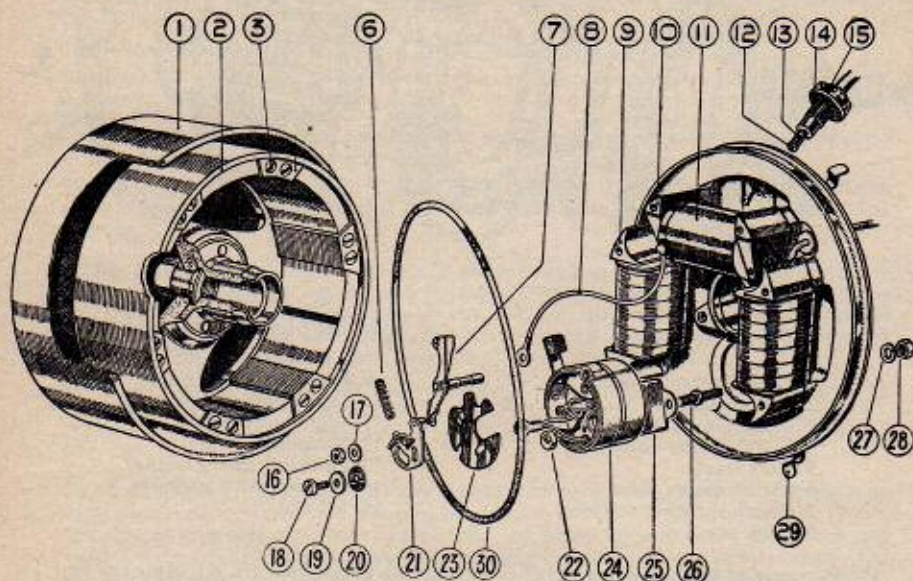

- |                               |                               |                                |
|-------------------------------|-------------------------------|--------------------------------|
| 1 Flywheel cover.             | 12 H.T. terminal pad.         | 22 Point bracket adjuster cam. |
| 2 Flywheel assembly.          | 13 H.T. terminal spring.      | 23 Insulating pad.             |
| 3 Screw, pole shoe.           | 14 H.T. terminal felt washer. | 24 Condenser box.              |
| 6 Rocker arm spring.          | 15 H.T. terminal.             | 25 Condenser.                  |
| 7 Rocker arm.                 | 16 Nut, L.T. lead.            | 26 Condenser box fixing stud.  |
| 8 Low tension lead.           | 17 Brass washer.              | 27 Washer for stud.            |
| 9 Lighting coils with checks. | 18 Lockscrew, point bracket.  | 28 Nut for stud.               |
| 10 H.T. coil end—left-hand.   | 19 Brass washer.              | 29 Flywheel cover clip.        |
| 10 H.T. coil end—right-hand.  | 20 Insulating washer.         | 30 Cover joint ring.           |
| 11 H.T. coil.                 | 21 Point bracket.             |                                |

### ADJUSTING CONTACT BREAKER POINTS.

Only a screw-driver is required to adjust the contact breaker points. To do so proceed as follows:

Turn flywheel clockwise until rocker pad is on top of cam profile of flywheel boss. Release screw "A". Position bracket "B" by turning adjuster cam "C" until .015" feeler gauge can be inserted between contact points. Tighten screw "A" and withdraw feeler gauge. It is not necessary to disturb nut "D" when adjusting point gap.

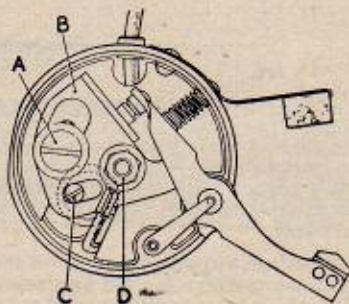



A hard felt pad is used to keep the cam in a slightly oily condition, and is impregnated with grease when new. This can, if visibly dry, be oiled with a small amount of the thickest oil available. If too much oil is put on the pad, it may creep along the rocker arm, get on the points and so cause ignition trouble.

**TIMING THE MAGNETO — CADET 150.** Timing marks are provided on the armature plate and flywheel rim. In the armature plate a slot is cut in line with the high tension terminal, and the mark stamped on flywheel rim coincides with the slot when the piston is at the TOP of stroke, the necessary amount of advance being allowed for. To check timing, fit flywheel loosely to shaft, and having set piston at  $\frac{3}{32}$ " before top dead centre, rotate flywheel without turning crankshaft until contact breaker points commence to open. Tighten up flywheel centre nut sufficiently to turn crankshaft, rotate until piston is at top of stroke, when timing marks should be opposite each other. Finally, tighten up centre nut hard and replace flywheel cover.

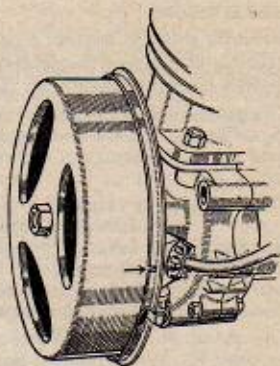

**HAMMER TIGHT SPANNER.** As its name suggests, this special spanner is designed to be struck with a hammer and constitutes a most useful addition to the toolkit of owners who undertake their own maintenance and major repairs. The "hammer-tight" spanner fits all Villiers engine sprocket and flywheel magneto retaining nuts. It may be purchased from any James Spares Stockists Part No. 703124 (price in U.K. 4/-).

**CONDENSER.** The condenser is fitted behind the contact breaker assembly and is retained by the studs securing contact breaker to armature plate. To replace the condenser, the complete contact breaker box must be removed and before this can be done, the four armature plate fixing screws must be taken out. Undo the two nuts at back of plate and unsolder the primary lead at the high tension coil. Unscrew the two studs holding condenser in position and remove screw holding the lead from condenser. This lead must be unsoldered to enable same to be withdrawn through hole in box.

A faulty condenser is usually indicated by continuous and excessive sparking at the contact points, but before fitting a new condenser, make sure the studs holding the condenser are really tight to ensure a good EARTH. Occasional sparking is normal and may be ignored.

## SPARE PARTS SUPPLY

James motor cycles are sold through appointed Dealers each of whom keeps at least a minimum stock of the spares most likely to be needed. We therefore strongly urge owners in their own interests to obtain their spares requirements from our appointed Dealers. When our Dealer is out of stock we will execute by return any urgent order received from him, always providing stocks are available at the factory.

In an emergency — for instance should a James owner be touring and out of contact with a James Dealer — we will supply direct against cash with order or by C.O.D. post. In this case, the fullest information as to the owners' requirements, including engine and frame numbers should be forwarded to us.

Normally the James Factory — to — Dealer organisation is the best and quickest way for an owner to obtain spares. We are always pleased to put owners into touch with their nearest James Dealer(s).



# Gearbox - Cadet 150

**DISMANTLING.** If it is necessary to gain access to the interior of the gearbox proceed as follows :

Drain oil through bottom plug (12).

Remove kick-starter lever (86) and foot gear control (49). Both are retained on their splined shafts by pinch bolts (51).

The gearbox dust cover (77) is held by three screws ; removal of this cover will give access to the bushed end plate (66). The clutch lever (83) will then come away, as it is held only by pressure of the clutch adjuster (82). Unscrew clutch cable adjuster at top left of end plate.

The end plate is retained in position by three screws and three hexagon nuts. Before removing them however, loosen large domed nut (65) alongside the foot lever shaft; this houses the selector plunger assembly. When all nuts and screws are removed, the plate will be ready to slide off : remove, leaving kick-starter shaft (40) in position in low gear ratchet pinion. If need be, the kick-starter pawl (41) may be removed by pressing down spring and plunger and sliding the pawl along its seating.

The mainshaft cannot be removed unless the clutch unit has been dismantled as described on page 40. When this has been done, the mainshaft will come away, leaving final drive sprocket (5) and high gear sleeve pinion (26) in position. The layshaft (30) may be withdrawn most easily by taking out the selector quadrant (18) retained by a bearing pin at the side of the box.

To replace the layshaft, pinion assembly and sliding pinion operator (33), push the layshaft right into its bush, ensuring the operator is correctly fitted. Before fitting the end plate, remove the plunger box nut (65) and spring (21) and place kick-starter shaft in the end plate bush, turning it to its stop pin (63). This will facilitate pushing the plate home.

The positive stop gear change mechanism at the back of the end plate should not be interfered with unless absolutely necessary, as it is very easy to re-assemble incorrectly. If, for any reason, dismantling is required, follow the order of assembly shown on the exploded drawing very closely.

The end plate and dust cover are thin aluminium alloy castings and when replacing fixing screws and nuts it is important that the respective washers should be in their recesses. The hexagon nut washers **MUST** be fitted, or a cracked dust cover may ensue. Clean all faced joints with petrol when re-fitting, using a jointing compound such as gold size.

The mainshaft fixed pinion (29) engaging with the layshaft ratchet pinion is a press fit on the mainshaft and cannot be easily removed whilst in the gearbox. This also applies to the fixed pinion on the layshaft (31).

If all the parts are correctly fitted and positioned, the end plate will slide home without difficulty. If it will not do so, do not force it on, but find out the reason.

It is best to strip and re-assemble the gearbox with the gears in the **NEUTRAL** position ; you can then ensure that the knob on the selector quadrant assembly is properly placed in the fork of the operating lever (58).

**ADJUSTING MAINSHAFT.** This is carried out by means of the adjuster bush (68) inside the dust cover end plate. Slacken locknut (69) and turn adjuster bush clockwise, until only a trace of end play exists. Tighten locknut securely. To avoid premature wear, leave a little end play (about .002").

After re-assembling gearbox, engage gears one by one to make sure everything is in working order.

**DISMANTLING FOOT CHANGE MECHANISM.** Remove the circlip outside the cover on the end of the foot change spindle, the shaft will then slide out complete with all the ratchet members. In order to strip down the shaft, turn down the locking plate tab (61) and hexagon nut (62). Note the position of all the parts before dismantling, as it is easy to re-assemble incorrectly, which will prevent the mechanism from working at all. Do not lose or damage the phosphor bronze shims (59) found under the washer with the "D" shaped hole. Before re-assembling make sure the face teeth on both ratchet members are not damaged. Do not attempt to remove the "D" shaped stop pin which is pressed into the gearbox cover.



## GEARBOX COMPONENTS — CADET 150

- 1 Gearbox, bushed.
- 2 Ball bearing.
- 3 Oil seal.
- 4 Sprocket distance piece.
- 5 Sprocket standard, 18 teeth.
- 6 Sprocket locknut.
- 7 Screw for locknut.
- 8 Spring washer.
- 9 Sealing disc.
- 10 Oil filler plug.
- 11 Washer for plug.
- 12 Oil drain plug.
- 13 Washer for plug.
- 14 Layshaft bush.
- 15 Stud for end plate.
- 16 Dowel.
- 17 Selector pivot pin.
- 18 Selector quadrant.
- 19 Selector plunger.
- 20 Plunger spring, short.
- 21 Plunger spring, long.
- 22 Oil level plug.
- 23 Washer for plug.
- 24 Mainshaft.
- 25 High gear pinion.
- 26 Pressure washer.
- 27 Pressure washer.
- 28 Mainshaft sliding pinion.
- 29 Mainshaft fixed pinion.
- 30 Layshaft.
- 31 Layshafts fixed pinion.
- 32 Layshafts sliding pinion.
- 33 Sliding gear operator.
- 34 Ratchet pinion.
- 35 Push rod, long.
- 36 Push rod, short.
- 37 Steel washer.
- 38 Felt washer.
- 39 Kickstart shaft, bushed.
- 40 Kickstart pawl.
- 41 Kickstart pawl plunger.
- 42 Plunger spring.
- 43 Sealing ring.
- 44 Operating spindle.
- 45 Sealing ring.
- 46 Pressure washer
- 47

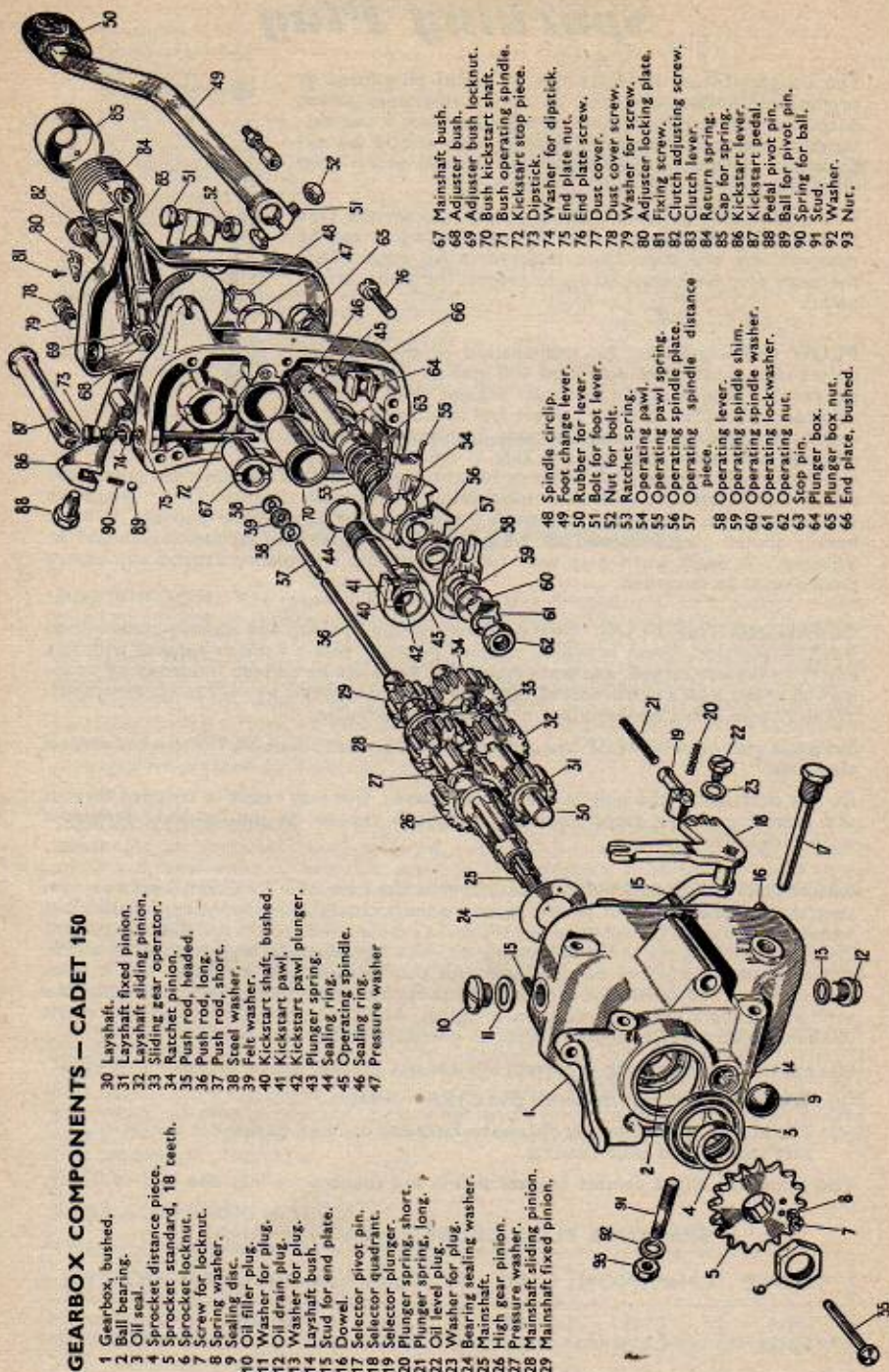

- 67 Mainshaft bush.
- 68 Adjuster bush.
- 69 Adjuster bush locknut.
- 70 Bush kickstart shaft.
- 71 Bush operating spindle.
- 72 Kickstart stop piece.
- 73 Dipstick.
- 74 Washer for dipstick.
- 75 End plate nut.
- 76 End plate screw.
- 77 Dust cover.
- 78 Dust cover screw.
- 79 Washer for screw.
- 80 Adjuster locking plate.
- 81 Fixing screw.
- 82 Clutch adjusting screw.
- 83 Clutch lever.
- 84 Return spring.
- 85 Cap for spring.
- 86 Kickstart lever.
- 87 Kickstart pedal.
- 88 Pedal pivot pin.
- 89 Ball for pivot pin.
- 90 Spring for ball.
- 91 Stud.
- 92 Washer.
- 93 Nut.

- 48 Spindle circlip.
- 49 Foot change lever.
- 50 Rubber for lever.
- 51 Bolt for foot lever.
- 52 Nut for bolt.
- 53 Ratchet spring.
- 54 Operating pawl.
- 55 Operating pawl spring.
- 56 Operating spindle piece.
- 57 Operating spindle distance piece.
- 58 Operating lever.
- 59 Operating spindle shim.
- 60 Operating spindle washer.
- 61 Operating lock-washer.
- 62 Operating nut.
- 63 Stop pin.
- 64 Plunger box.
- 65 Plunger box nut, bushed.
- 66 End plate, bushed.



# Sparking Plug

The Lodge H14 or HH14 (14 mm.  $\frac{1}{2}$ " reach) plug fitted as original equipment will stand up to the maximum power output of the engine without pre-ignition and if the carburetter mixture is correct, little trouble should be experienced. The point gap should be checked every 2,000 miles and reset to .018"—.025" if necessary.

It is a good plan to carry a spare plug of the correct type so that when the plug in use requires cleaning, it can be removed and the clean spare inserted in its place. Keep the spare plug well wrapped up, to protect the all-important points.

**PLUG DIAGNOSIS.** An examination of the sparking points after a period of operation will give an indication of the running conditions of a particular engine. With properly adjusted carburation and the correct fuel mixture, a plug of the correct grade will bear a light grey deposit on the outer rim and earth electrodes, and the base of the insulator will be light brown in colour. A white or bleached appearance of the electrode points and outer rim indicates pre-ignition or overheating due to weak mixture. Other symptoms will probably be spitting back through the carburetter and audible pinking. A black heavily sooted plug denotes that the mixture is too rich and carburation should be adjusted. A badly worn plug with burnt electrodes and pitting around the centre piece should be discarded.

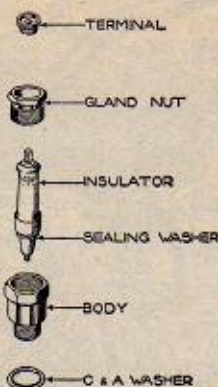

**CLEANING THE PLUG.** Grip body very gently in a vice and remove gland nut to free the insulator. Wash in petrol, scraping insulator with a knife or rubbing with fine emery to remove carbon, and wash again. The body can be cleaned internally by scraping and wiped with a petrol-soaked rag. The electrodes should be very carefully scraped. When re-assembling tighten gland nut as much as possible.

Set point gaps to .018"—.025" by tapping OUTSIDE electrodes—NEVER tap the central electrode.

Do not overtighten the plug in the cylinder head; this may result in stripped threads and flattening of the copper washer. A whitish deposit on the insulator denotes a weak carburetter mixture.

**BRIDGING OF PLUG GAP.** This occurs in the form of a "whisker" between the central electrode and earth points, causing a short circuit and preventing a spark. It is sometimes mistaken for oiling-up but the cause is believed to be the residue of detergent in varying percentages in the lubricating oil. The high working temperatures of a two-stroke engine appears to be the reason for this bridging and it follows that a weak mixture, retarded ignition, a choked exhaust system or anything likely to increase the working temperature may result in bridging. Attention to the following will result in an increased mileage before it becomes necessary to clear the points.

- (a) Ensure ignition timing is correct and contact breaker gap is between .014"—.016".
- (b) The carburetter may be set to give a richer mixture.
- (c) The normal spark plug gap should be increased as much as possible consistent with easy starting and good running.

Poor condition of the contact breaker points and connections may also lead to failure.

## SPARKING PLUG CROSS REFERENCE CHART

LODGE	CHAMPION	AC	K.L.G.	AUTOLITE	BOSCH
H14 HH14	L10S LA10	F8	F70 F80	AE4, AER4	W225T1 or T11 W240T1 or T11



# Decarbonising

We do not specify any particular mileage at which to carry out the task of decarbonisation as the rate at which carbon forms is dependent upon the way the rider treats his machine and also the type of riding it is used for. Carbon tends to form more quickly if a machine is used for short journeys than on long runs, when the engine becomes really warm and will blow out most of the carbon. Hence, while one machine may require attention at 2,000 miles another might have accumulated only a slight deposit at 5,000 miles. Irrespective of mileage, it will be time to decarbonise when excessive pinking is heard.

## SEQUENCE OF OPERATIONS FOR DECARBONISING.

Remove H.T. lead from sparking plug, disconnect fuel pipe from tank, remove carburettor and exhaust pipe nut from cylinder.

Slacken cylinder head bolts, a quarter of a turn at a time, working diagonally, remove bolts and lift cylinder head. (On Cadet 150 the cylinder head steady tube should be taken off).

Slacken and remove cylinder base nuts and spring washers, working diagonally as for head. Position piston at bottom of stroke.

Lift cylinder in a steady movement: do not twist or piston rings may be trapped in the ports.

Remove piston by extracting circlips with thin nosed pliers. Tap gudgeon pin out gently with a suitable drift, holding piston so that no shock is transmitted to the connecting rod, use a gudgeon pin extractor. It is not necessary to remove gudgeon pin completely.

At this stage it is as well to check big end and main bearings for wear. Big end wear can be detected by feeling for up and down movement of the connecting rod. Main bearings generally produce audible noises but the R.H. bearing can be checked by trying to move the flywheel magnets UP and DOWN. If no wear is apparent proceed:

Remove carbon deposit from cylinder head by careful and gentle scraping with a piece of copper strip or stick of solder sharpened to "screwdriver" shape. Avoid using a steel instrument as this may damage the aluminium alloy.

Carbon will form around the edges of the exhaust port and may, if neglected, constrict the orifice and hinder the passage of gases. Remove by chipping, taking care not to damage the bore.

The piston may be cleaned in the same way as the cylinder head and the top rubbed gently to remove all traces of carbon. The piston rings may be removed without risk of damage by introducing three pieces of thin metal strip spaced round the piston (see illustration) and then sliding off the ring. Do not scratch the piston. The piston ring grooves should be cleared of carbon. A good method is to use a piece of broken piston ring and finally polishing with a length of thin string.

Performance immediately after a decoke may be below normal and will improve as soon as a slight carbon deposit has built up on the piston crown. Tighten all bolts after 200 miles following a decoke.

If piston rings are cracked or show brown patches (denoting gas leakage) replace with new ones. If the old rings are retained it is desirable to refit each ring in its original groove.

When re-assembling, fit piston in same manner as it was removed. The top piston ring peg should face forwards. Do not forget to refit circlips.

Make sure all faced joints are clean and free from grit when re-building. Always fit new cylinder base and cylinder head gasket.





Smear cylinder wall with oil, slide cylinder over the rings with piston at bottom of stroke by pressing side of ring opposite peg into slot and canting cylinder over to retain ring. Press in ring on either side of peg and swivel cylinder gently to and fro gradually lowering over ring. Repeat for lower ring.

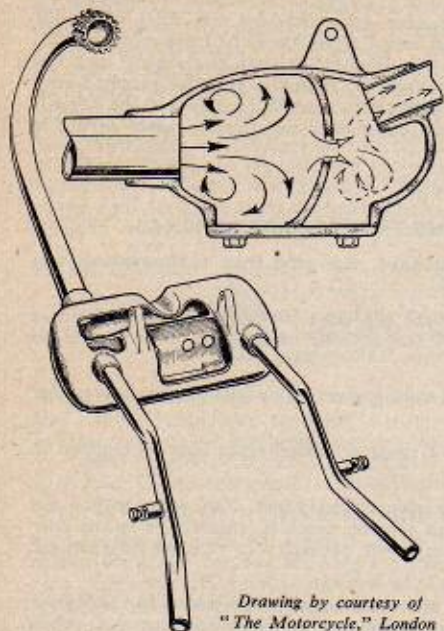

Drawing by courtesy of  
"The Motorcycle," London

removed for cleaning. A plate on the underside is provided for this purpose and it is secured by 4 screws.

**REMOVAL OF CADET SILENCER.** Detach the silencer and separate it from the exhaust pipe. There is a rubber sealing ring between the two components and this will have to be renewed on re-assembly.

Tighten cylinder base nuts and cylinder head bolts evenly a quarter of a turn at a time and working diagonally. Remember to fit spring washers under base nuts.

**CLEANING THE SILENCER.** It is advisable to remove the silencer for cleaning when decarbonising the engine and when dismantled the silencer and exhaust pipes should be flushed out with household detergent and boiling water to remove all oil and carbon. It may sometimes be necessary to use a stiff brush.

Another method is to insert a lighted gas poker into each unit for a few minutes. This effectively burns the oily carbon deposit and a few sharp taps on the sides of the exhaust pipe and silencer will clean out the remains.

**REMOVAL OF COMET SILENCER.**

Begin by unscrewing the exhaust pipe nut at the cylinder and detach the exhaust pipe from the silencer. Then remove the two tail pipes attached to the centre section by  $\frac{3}{8}$ " bolts. All pipes are push-fits in the casting. It is now only necessary to remove the long transverse bolt and the silencer can be

## Tracing Troubles

For the satisfactory running of two-stroke engines it is essential that three main conditions are fulfilled, and by making a systematic and intelligent investigation the faults can usually be located. If the engine stops, symptoms will generally give a clue to the cause, but where this is not the case, the trouble can be more easily traced by following a definite method of investigation. The three conditions mentioned above are as follows :

- (1) The required quantity of petrol-and-air mixture must enter the engine, which means that a proper supply of fuel has to be available from the carburetter, and that the throttle should open and close freely.
- (2) The sparking plug must give a good spark, at the right time in relation to the position of the piston on its upward stroke.
- (3) The engine must be in good mechanical condition, with no air leaks at the various joints.

For further information refer to pages 52, 53.



There must also be efficient compression of the air in the cylinder and crankcase. This can be easily checked by putting the gearbox into neutral position, and rotating the crankshaft by means of the kickstarter. On every revolution a definite resistance should be felt, caused by the air in the cylinder being compressed.

**ERRATIC RUNNING.** Erratic running at slow speeds may be due to : air leaks, either at carburetter stub joint, due to carburetter not being pushed home, cylinder base joint, crankcase joint face or gland bush. Trouble may also be caused by over advanced ignition setting, sparking plug points too close, corroded or dirty, contact breaker points dirty, pitted, loose or set too close or defective plug lead.

**WEAK MIXTURE.** This may be caused by choked gauzes in fuel supply system. After considerable mileage, wear of the throttle slide and/or carburetter body may cause weak mixture.

**HEAVY FUEL CONSUMPTION.** This may be due to :

Retarded ignition setting.

Carburetter flooding due to leaking float, or bad seating of fuel needle. This may be caused by dirt or wear.

Worn carburetter jet or centrepiece hole and/or taper needle, usually after considerable mileage. Remedy is to replace worn parts.

Taper needle adjustment too rich.

Poor compression due to worn piston rings and/or worn cylinder bore.

Choked silencer and exhaust system. Incorrect petrol-oil mixture. High altitudes may also affect carburation.

**MAKING A PRELIMINARY CHECK.** When the cause of the trouble is not evident, carry out a preliminary check covering the following points :

Make sure there is "petrol" in the tank, and that the tap is "ON". Depress the tickler on the carburetter to ensure there is no blockage in the fuel supply, either in the tap, fuel pipe, banjo union or fuel needle seating. If the fuel supply is clear, fuel will spurt from the vent hole in the side of the tickler cap. Examine the throttle twist grip control to make certain that the throttle is actually opening when the twist grip is moved.

Being satisfied that fuel is reaching the carburetter, next unscrew the sparking plug, and with the high tension lead still attached, lay the plug on the cylinder head. Turn the engine by means of the kickstarter, and if there is a good spark, it is possible that the ignition timing is incorrect.

**SYMPTOMS OF ENGINE WEAR — BEARINGS.** After considerable service or as a result of inadequate lubrication or negligent driving, wear may occur in the mainshaft and connecting rod bearings.

In both cases the engine will become noticeably rough and probably produce rumbling noises in the case of worn main bearings and definite knocking sounds with a worn big end bearing. Small end wear alone is of little importance and is difficult to detect.

Main bearing wear can be checked by removing the flywheel magneto cover and feeling for up and down movements of the mainshaft by attempting to lift the flywheel.

To check big end wear, remove cylinder head, carburetter and cylinder. Hold the connecting rod firmly in the hand and feel for **up** and **down** movement at the bearing. Sideways movement of the connecting rod can be ignored.

If either main bearing or big end bearings are worn, owners are advised to obtain a replacement crankshaft assembly.

**CYLINDER.** Cylinder wear will normally occur only after a long period, but premature wear can be caused by careless running-in or insufficient or poor quality lubricant. The most obvious symptoms will be a general drop in performance and audible piston slap and/or ring rattle.

Lack of power can, of course, be due to reasons other than cylinder wear, but if after checking ignition and carburation engine performance is still below normal, strip the



engine and examine the piston rings, piston and cylinder walls for signs of wear in the form of burns, score marks, cracked rings and ovality of the cylinder bore. If the bore is clean, replacement piston rings will often improve engine performance. If a rebore is required, oversize pistons and rings are available (-015" O/S—030" O/S). Always fit new cylinder base washer when re-assembling the engine. The cylinder head washer may not appear to be damaged but it is advisable to fit a new one each time the head is removed.

**IGNITION FAILURE.** The cause of ignition failure will generally be found to be due to the condition of the sparking plug or contact breaker points, or faulty insulation of plug lead or contact breaker connections. Serious trouble in the form of condenser or coil breakdown is very rare.

The first step in dealing with ignition trouble should be to remove plug from engine and examine the points to see whether they are oily and the gap correctly set between .018" and .025". If the insulator is fouled with oil and carbon, there may be sufficient leakage to prevent correct sparking and cleaning will be necessary. Fitting a new plug will readily show whether the failure is due to plug or not.

The plug lead should then be examined for cracks or other faults. The contact breaker can then be examined without removing the flywheel to see whether the points are opening correctly. When the points are fully open there should be a gap of .015". The surfaces must also be clean and free from oil and severe pitting. A piece of stiff paper will usually remove oil or grease. If the points are burned or pitted they should be cleaned with a fine carborundum stone if available, otherwise fine emery cloth can be used, wiping off any traces of metal or emery dust with a petrol-soaked rag.

As a result of wear of the heel of the rocker arm bearing on the cam the point gap will be reduced. This wear should be negligible if the felt oiling pad is kept moist with suitable lubricant.

Poor ignition may sometimes be traced to a worn contact breaker spring — easily replaced.

---

## *Cleaning*

Make a practice of giving the machine a really good clean as often as possible, keeping a soft cloth specially for the purpose. By careful cleaning the original sheen of enamelled parts may be retained indefinitely.

Where mud is thickly caked on, do not attempt to brush it off; abrasive particles will rapidly damage the enamel. Water from a small hose or a wet sponge should be used, taking care not to let water into the carburetter, magneto and brake linings.

Never garage a dripping machine after a wet run. Remove moisture by dabbing gently with a soft cloth, i.e., butter muslin.

Salt laid down in city streets during snowy winter periods has a corrosive effect on enamel and chromium plating. A useful tip is to smear the wheel rims and other exposed parts of the machine with a film of oil or grease. This can easily be removed with a petrol-soaked rag when the weather improves.

James "Touch up" units incorporating a retractable nylon brush and a quantity of James maroon quick drying enamel may be purchased from any James Spares Stockist and will be found useful for retouching small scratches where the paintwork has been damaged.

**CHROMIUM PLATING.** In damp weather, small spots of rust-like deposit may be observed on chromium plating. It is not rust but the action of certain salts used in the plating process. If attended to in good time such spots can easily be removed by rubbing with a good brand of chromium polish. NEVER USE HOUSEHOLD METAL POLISH ON CHROMIUM PLATING.

In summer, when wet conditions are less frequent, it is best to clean plating with a damp chamois leather cloth and soft rag.



**ALUMINIUM ALLOY CASTINGS.** A certain amount of road dirt and oil will inevitably gather on the cast alloy surfaces of the engine crankcase, primary chaincase, gearbox and carburetter, and regular cleaning will not only improve the appearance of the machine but will avoid dirt stains on trouser legs and shoes. A clean engine unit is also easier and more pleasant to maintain.

Such parts can be cleaned with a stiff brush dipped in petrol or trichloethylene or, alternately, we recommend a special detergent available from most motor cycle accessory retailers, i.e., GUNK. This product is simply brushed on to the alloy parts and hosed off with water. Gunk is sold in tins and full instructions are given by the makers.

If this method of cleaning is employed care should be taken to cover the carburetter to prevent the entry of water and consequent starting difficulties. Surplus water should always be wiped off with a clean rag.

**TOOLS.** The standard tool kit supplied with new machines consists of :

- |   |   |
|---|---|
| 1 Plug spanner.   | 1 Open ended $\frac{7}{16}$ " $\times$ $\frac{1}{2}$ " spanner. |
| 1 Magneto screwdriver and .015" feeler gauge.                   | 2 Tyre levers.  |
| 1 Screwdriver   | 1 Hand pump.  |
| 1 Exhaust pipe spanner.   | 1 Cone spanner.   |
| 1 Open ended $\frac{9}{16}$ " $\times$ $\frac{1}{4}$ " spanner. | 1 Pair pliers.  |
| 1 Open ended $\frac{5}{8}$ " $\times$ $\frac{3}{8}$ " spanner.  | 2 Steering head spanners.                                       |

**Special tools available.**

Villiers hammer tight spanner (Part No. 703124)

$\frac{1}{4}$ " Socket spanner — for unscrewing mudguard stay fixing pins.

Jet block spanner (St. 1692D) for S.12 carburetter.

Rivet extractor (Part No. 000552)

Oil gun (Part No. 003934).

**Optional Equipment.**

Combined legshield and engine cover.

Passenger seat.

Passenger footrests.

Rear carrier (instead of pillion).

Pannier frames and bags.

Windscreen.

Licence holder.

A.C. electric horn.

A.C./D.C. lighting set.

D.C. electric horn.

D.C. stop lights.

## MAJOR REPAIRS

The contents of this booklet are intended to give the owner a working knowledge of his machine and to enable him to carry out normal adjustments, maintenance and simple repairs. Where major repairs are concerned, we strongly advise the amateur mechanic to leave well alone and entrust difficult jobs, should they ever arise, to a qualified mechanic. Splitting the crankcase halves, for instance, is a very difficult matter and demands great skill and care, while years of experience are needed to replace a big end assembly and true the shafts. Our Repairs Department is fully equipped and major repairs carry a full three months' guarantee. With these facilities at the disposal of James owners, we feel that it will repay our customers not to attempt too much but to keep within the limits outlined in this book.



# ***Fault Finding Chart***

Sequence of Testing.	Possible Trouble.	Remedy.
<b>Engine will not start.</b>		
Depress tickler on carburetter to check whether fuel is reaching carburetter.	No fuel reaching carburetter air lock in petrol pipe.	Turn tap to ON, refill tank, clear air vent in filler cap.
If no fuel, even when tap is on and fuel is in tank.	Choked petrol pipe, filter on tap, filter in banjo. Fuel needle sticking in seating.	Remove and clean out. Dis- mantle carburetter and fit new needle.
Test for spark by holding spark- ing plug body on cylinder head.	Leak along insulation of plug or high tension lead.	Try a new plug of the type recommended and/or new H.T. lead.
If still no spark : Test for spark at end of H.T. lead held $\frac{1}{4}$ " from cylinder fins.	Plug points may be oily or sooted up. If no spark at end of H.T. lead, contact breaker point gap may be too narrow or points pitted or dirty or oily.	Clean plug or fit new one. Adjust point gap to .015". Clean.
	Moisture on insulation of con- denser.	Clean and dry out.
	High tension terminal not making good contact on ignition coil.	Clean and correct.
	Cracked insulation of adjustable contact breaker point.	Replace.
	Damaged insulating sleeving on wires connecting contact breaker to coil or condenser.	Replace with new sleeving.
	Faulty connection to low tension wire of ignition coil.	Correct.
	Faulty condenser.	Replace.
	Faulty ignition coil.	Replace.
If above tests are satisfactory but engine will not start.	Mixture may be too rich due to use of strangler, or incorrect setting of taper needle.	Open throttle wide and depress kickstarter several times to clear engine of petrol, drain crankcase.
	Air leaks at carburetter stub or manifold joint causing weak mix- ture.	Tighten joints evenly.
	Incorrect ignition timing.	Check, following instructions given.



## FAULT FINDING CHART — (continued)

Sequence of Testing.	Possible Trouble.	Remedy.
<b>Engine Four or Eight Strokes.</b>		
Strangler may not be fully open or taper needle in a too high position. Air filter may need cleaning.	Mixture too rich.	Lower taper needle by moving to a WEAKER position. Lower needle by adjuster screw fitted in throttle.
Check by watching for excessive smoke from exhaust pipe or silencer.	Engine may four stroke for a little while after standing due to accumulation of oil in crankcase.	Usually ceases when engine has been running for a few minutes unless too much oil has been mixed with the petrol.
	Flooding of carburetter.	Persistent flooding is usually due to dirt under fuel needle seating, or sticking fuel needle, damaged seating or punctured floats.
<b>Engine Lacks Power.</b>		
	Engine out of tune, bearings worn. Unsuitable sparking plug.	Overhaul. Replace with recommended type.
	Loss of compression.	Tighten cylinder head bolts, Replace worn piston rings.
	Incorrect "petrol" mixture.	Correct mixture is 1 part oil, 20 parts petrol.
	Excessive carbon deposit on piston crown and cylinder head.	Decarbonise.
	Exhaust system choked with carbon.	Clean out silencer and exhaust pipes.
	Incorrect carburetter setting.	Check and adjust.
	Air cleaner choked.	Wash in petrol, drain and dip in thin oil.
	Obstruction in fuel supply.	Clean out tap, fuel pipe and filters.
	Incorrect ignition timing.	Check and adjust.
	Brakes binding.	Adjust.
	Driving chains too tight.	Adjust.
<b>Engine will not run Slowly.</b>		
	Weak mixture due to air leaks at carburetter scrub or manifold joint, crankcase and cylinder base joints.	Tighten all joints evenly.
	Crankcase drain screw loose or missing.	Tighten or replace.
	Worn crankshaft bearings or leaking seal.	Replace.
	Ignition timing too far advanced.	Correct.
<b>Engine Suddenly Stops Firing.</b>		
	Sparking plug lead detached.	Replace.
	Plug points bridged by oil, carbon, or deposit caused by use of leaded petrol.	Clean or replace.
	Short circuit of high tension lead to frame possibly by water on H.T. lead.	Insulate. If wet, dry out.



# Lighting Equipment

**DIRECT LIGHTING.** Both Comet 100 and Cadet 150 models are normally supplied with direct lighting equipment in which alternating current is supplied by the flywheel generator when the engine is running. The lights are controlled by the main switch in the headlamp shell and the headlamp beam can be dipped by means of the dipper switch on the handlebar.

Provision is made for fitting a twin cell dry battery for parking lights and clips and wiring will be found in the headlamp shell on the Comet 100 and inside the toolbox on the Cadet 150. Owners are advised to make maximum use of the direct lighting and to switch on to the dry battery for parking only. The dry battery receives no charge and should be replaced when exhausted.

## DIRECT LIGHTING—COMET 100

**HEADLAMP—COMET 100.** The headlamp is of straightforward construction and all parts may be dismantled for replacement when necessary.

### REPLACEMENT BULBS—COMET 100.

Headlamp main bulb	...	...	6 volt, twin filament 24/24 watt Pre-focus.
Headlamp parking light	...	...	3.5 volt, .15 amp., M.E.S.
Tail light bulb	...	...	6 volt, 3 watt, B.C.
Speedo bulb (if fitted)	...	...	6 volt, .15 amp. M.B.C.

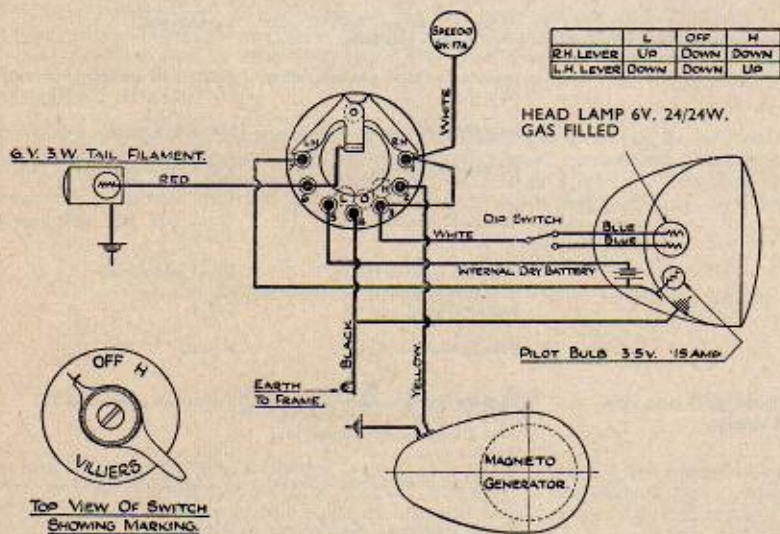

WIRING DIAGRAM—COMET 100 (Direct Lighting).

## DIRECT LIGHTING—CADET 150

**HEADLAMP—CADET 150.** The main bulb has twin filaments, one filament providing the main driving beam and the other a dipped beam, brought into operation by the dipper switch on the left handlebar, when required. The pilot bulb is mounted behind the reflector and shines through a small window in the reflector under the main bulb.



The design of the lamp holder, lamp and reflector assembly is such that when the bulb is correctly positioned, no focussing is required.

The reflector and front glass are made up as one assembly and no attempt should be made to separate them. The components cannot be purchased separately.

**TAIL LIGHT.** Of Wico-Pacy design, the new tail light incorporates a reflecting surface complying with British traffic regulations. Wiring is the same as on 1956 models, but twin bulbs are employed. These are 6 volt, 3W. M.E.S.

**STOP LIGHT.** On models with rectifier-battery lighting, a stop light switch may be fitted and provision is made inside the tail light for a stop light bulb—6 volt, 18W. S.B.C.

**REMOVING LIGHT UNIT AND RIM.** Slacken the screw on top of the lamp body at the front, pull the rim outwards from the top and, as the front comes away, lower slightly to disengage bottom tag from lamp shell. Twist the back shell in an anti-clockwise direction and pull it off. The main bulb can then be removed from its housing in the reflector assembly. The lamp rim is secured to the light unit by spring clips which can be removed by pressing with a screwdriver blade, at the same time working away from the edges.

**REPLACING LIGHT UNIT AND RIM.** Lay the light unit in the rim so that the location block on the unit engages with the forked brackets on the rim. Replace the clips by springing in, so that they are evenly spaced around the rim. To replace the back shell, engage the projections on the inside of the back shell with the slots in the holder, press on and secure by twisting it to the right. Engage bottom tag on headlamp rim with the small slit in the shell, and gently force the top of the rim back into the shell, after which re-tighten the locking screw on the top of lamp body.

#### REPLACEMENT BULBS — CADET 150 (Direct Lighting).

Headlamp main bulb	...	...	...	6 volt 30/24 watt pre-focus.
Headlamp parking light	...	...	...	3.5 volt .15 amp., M.E.S.
Tail light bulb	...	...	...	6 volt 3 watt, B.C.
Speedometer bulb	...	...	...	6 volt .15 amp., M.B.C.

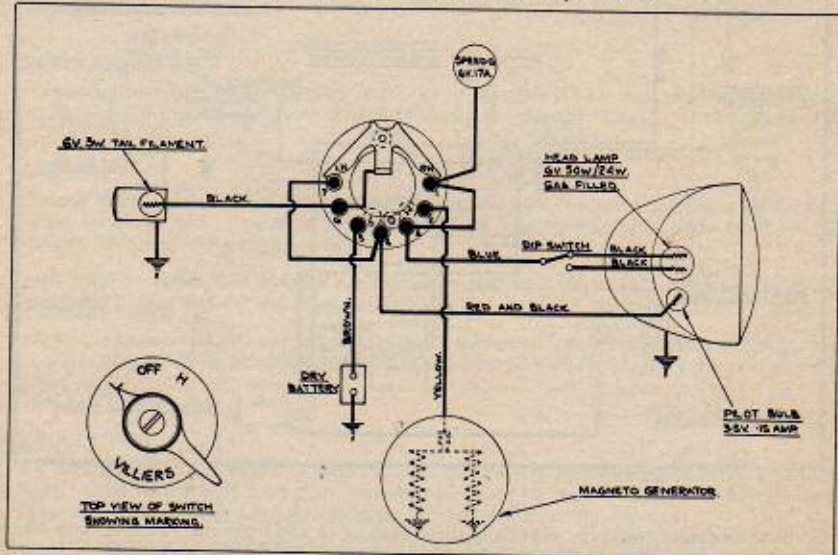

WIRING DIAGRAM — CADET 150 (Direct Lighting).



## RECTIFIER BATTERY LIGHTING.

A rectifier-battery lighting set can be fitted to both Comet 100 and Cadet 150 models. The rectifier is fitted under the cushion seat and the battery is a Lucas PUZ/5E/10, 6 volt, 10 amp. hour mounted inside the frame centre section.

The switch provided on this headlamp is designed to enable the rider to illuminate the headlamp bulb either by—

A.C. current direct (switch position marked "Direct").

D.C. current (switch position marked "H").

Parking lights and other accessories are always operated on current obtained from the battery.

The advantage of this system is that the rider can be completely independent of the state of charge in the battery for night driving. All that is necessary to change from A.C. to D.C. is to move the switch from position "Direct" to "H."

When the switch is in the direct position, no light can be obtained at the main bulb when the engine is not running, because in this position the bulb is not connected to the battery and no current is being produced by the generator.

In all the other switch positions the lamps are independent of engine speed, as they are connected to the battery through the headlamp switch.

It is recommended that the "Direct" position should be used on every possible occasion, as by this means no current is being taken from the battery to the headlamp. In addition to this, a small charge will also be given to the battery when the engine is running at moderate speeds.

*Blue & Brown BATT GREEN & BROWN Tail RECT CENTRE*

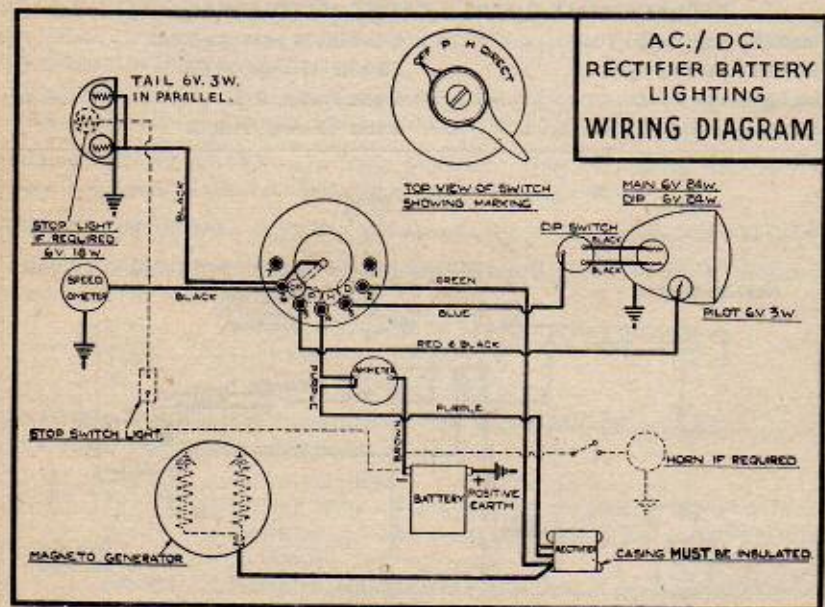

Go over all cables regularly, especially those leading to and from the Rectifier, and make sure that none of them is fraying. Should any show signs of doing so bind them at once with plenty of insulating tape and ensure that they are no longer able to flap about.



## IMPORTANT

Provided that the negative battery lead is suitably insulated, and the wiring is in good condition, no damage to the Rectifier will occur if the engine is used without the battery. It should, however, be clearly understood, that the switch should not be put to the "PARKING" position whilst the engine is running.

## BATTERY MAINTENANCE.

Deterioration soon sets in if the battery is left standing without attention for any length of time. To keep the battery in good condition, maintenance must be carried out whether the machine is in use or not.

Every month (every fortnight in summer), remove battery from the machine clean terminals, and top-up the three cells to  $\frac{1}{8}$ " above the level of the plates with distilled water—NOT tap water, as this contains impurities detrimental to the battery. Pour the distilled water through a glass funnel or syringe.

Many lighting troubles can be traced to unseen corrosion between the surfaces of the battery terminals; the positive is earthed to reduce this effect to a minimum, but keep the terminals clean. A little grease smeared on them will help prevent corrosion. Do not keep distilled water in receptacles made of any kind of metal as this will quickly render it impure—make use of a clean glass bottle or jar. Rainwater collected in a jar makes a satisfactory substitute for distilled water.

NEVER bring a naked light near a battery with vent plugs removed or when the battery is being charged; the gas given off by the electrolyte is dangerously explosive.

Battery acid is highly corrosive; therefore throw away any cleaning rags used to clean the battery lest their use on other parts of the machine causes damage.

NEVER let a battery completely run down; if this does occur, get it charged as soon as possible, or its length of life may be seriously shortened.

## SPARE PARTS SUPPLY

James motor cycles are sold through appointed Dealers each of whom keeps at least a minimum stock of the spares most likely to be needed. We therefore strongly urge owners in their own interests to obtain their spares requirements from our appointed Dealers. When our Dealer is out of stock we will execute by return any urgent order received from him, always providing stocks are available at the factory.

In an emergency — for instance should a James owner be touring and out of contact with a James Dealer — we will supply direct against cash with order or by C.O.D. post. In this case, the fullest information as to the owners' requirements, including engine and frame numbers should be forwarded to us.

Normally the James Factory — to — Dealer organisation is the best and quickest way for an owner to obtain spares. We are always pleased to put owners into touch with their nearest James Dealer(s).



# Technical Data - Comet 100

Engine . . . . .	Villiers Mk. 4F two-stroke unit or 6F (optional).
Cubic Capacity . . . . .	98 cc. (6 cu. ins.).
Stroke . . . . .	57 mm. (2.244").
Bore . . . . .	47 mm. (1.8504").
Compression Ratio . . . . .	8 : 1.
Approx. Brake Horse Power	2.8 B.H.P. at 4000 R.P.M.
Ignition Timing . . . . .	Points commence to open $\frac{1}{8}$ " before top dead centre.
Contact Breaker Gap . . . . .	.015" maximum separation.
Sparking Plug Type . . . . .	Lodge H14. 14 mm. short reach.
Sparking Plug Gap . . . . .	.018"/.025".
Correct Lamp Bulbs . . . . .	Headlamp main bulb 6 volt. 24/24W pre-focus. Parking light ... 3.5 volt. .15 amp. M.E.S. (A.C. direct lighting) Tail light ... 6 volt. 3W. B.C. Speedo light (if fitted) 6 volt. .15 amp. M.B.C.
Carburettor . . . . .	Type : Villiers type S12. Jet size : 85 cc. Taper Needle : No. 2.
Sprockets . . . . .	Engine : 17 teeth. Clutch : 42 teeth. Final drive : 14 teeth. Rear : 48 teeth.
Chains . . . . .	Primary : Renold $\frac{3}{8}$ " x $\frac{1}{4}$ " x .225" pre-stretched. 56 links. Rear : Renold $\frac{1}{2}$ " x .305" x .192". 122 links.
Rear Chain Adjustment . . . . .	Unladen : $\frac{3}{8}$ " to 1" whip. Laden : $\frac{3}{8}$ " to $\frac{1}{2}$ " whip at tightest point.
Gearbox Ratios . . . . .	1-64 : 1 and 1 : 1.
Overall Gear Ratios . . . . .	First : 13.9 and 1 : 1. Top : 8.5 : 1.
Engine Bearings . . . . .	Ballraces (2) 25 x 52 x 15 mm.
Big End Bearing . . . . .	Roller (28) .1876"/.1874" dia. x .1877"/.1873" long.
Hub Bearings. . . . .	Front cup and cone : 20 balls $\frac{1}{4}$ " dia. Rear journal : 15 x 42 x 13 mm. Skefko 6302.
Steering Head Bearings . . . . .	Ball : 17 per race $\frac{1}{4}$ " dia.
Wheel Rim Sizes . . . . .	Front and rear : WMO 19.
Tyre Sizes . . . . .	Front and rear : 2.25" x 19".
Tyre Pressures - Normal . . . . .	Front : 20 lbs. Rear : 25 lbs.
Spokes . . . . .	Front (36) : $7\frac{1}{2}$ " x 12 swg. Nipples (36) : .225" x 12 swg. Rear (36) : $7\frac{1}{4}$ " x 10 swg. Nipples (36) : .225" x 10 swg.



<b>Brake Drum Diameters</b>	Front : 4" (10.16 cm.). Rear : 5" (12.7 cm.).
<b>Total Braking Area</b>	11 $\frac{3}{4}$ " (76 cm <sup>2</sup> ).
<b>Fuel Tank Capacity</b>	2 $\frac{1}{4}$ Imperial gallons (10.2 litres).
<b>Fuel Mixture</b>	One part recommended oil to 20 parts petrol. ( $\frac{1}{2}$ pint oil to 1 $\frac{1}{2}$ gallons petrol or 4 filler cap measures to one gallon petrol).
<b>Oil Capacity of Chaincase and Gearbox</b>	Approx. $\frac{1}{4}$ pint. Fill to oil level plug.
<b>Speedometer</b>	A speedometer is not required by law on motor cycles under 100 c.c. and is not included in the standard specification of the Comet 100. The speedometer head fits into the headlamp shell and cable and speedo drive are as for the 150 c.c. model.
<b>Wheelbase (static)</b>	49 $\frac{1}{2}$ " (125.8 cm.).
<b>Seat Height</b>	29" (73.6 cm.).
<b>Ground Clearance</b>	5" (12.7 cm.).
<b>Width Over Bars</b>	26" (66 cm.).
<b>Overall Length</b>	76 $\frac{1}{2}$ " (194 cm.).
<b>Approx. Weight</b>	165 lbs. (74.9 kilos).

---

## **Technical Data—Cadet 150**

<b>Engine</b>	Villiers Mk. 30C two-stroke unit.
<b>Cubic Capacity</b>	147 cc. (9.0 cu. ins.).
<b>Stroke</b>	62 mm. (2.440").
<b>Bore</b>	55 mm. (2.167").
<b>Compression Ratio</b>	8.3 to 1.
<b>Approx. Brake Horse Power</b>	5.43 B.H.P. at 4-250 R.P.M.
<b>Ignition Timing</b>	Points commence to open $\frac{5}{8}$ " before T.D.C.
<b>Contact Breaker Gap</b>	.015" maximum.
<b>Sparking Plug Type</b>	Lodge H14 (14 mm.).
<b>Sparking Plug Gap</b>	.018/.025".
<b>Correct Lamp Bulbs</b> (A.C. Direct lighting)	Head main : 6 volt—30/24 watt, pre-focussed. Head pilot : 3 $\frac{1}{2}$ volt—15 amp., M.B.C. Tail : 6 volt—3 watt, B.C. Speedo : 6 volt—17 amp., M.B.C.
<b>Carburettor</b>	Type : Villiers S.19 single lever. Size of main jet : No. 80. Taper needle : No. 3 $\frac{1}{2}$ . Normal needle setting : 2.015" out.



<b>Sprockets</b>	Engine : 23 teeth. Clutch : 51 teeth. Gearbox : 16 teeth. Rear : 48 teeth.
<b>Chains</b>	Primary : Renold $\frac{3}{8}$ " $\times$ $\frac{1}{2}$ " $\times$ .225" pre-stretched. 64 links. Rear : Perry $\frac{1}{2}$ " $\times$ .335" $\times$ .205". 121 links.
<b>Rear Chain Adjustment</b>	Unladen : $\frac{3}{8}$ " to 1" whip. Laden : $\frac{3}{8}$ " to $\frac{1}{2}$ " whip at tightest point.
<b>Gearbox Ratios</b>	1, 1.34, 2.55 to 1.
<b>Overall Gear Ratios</b>	Bottom : 16.9 to 1. Second : 8.9 to 1. Top : 6.6 to 1.
<b>Engine Bearings</b>	Ballraces (3) : 20 $\times$ 47 $\times$ 14 mm.
<b>Big End Bearings</b>	Rollers : $\frac{1}{4}$ " dia. $\times$ $\frac{1}{4}$ " long (12 steel, 6 bronze) $\frac{1}{4}$ " dia. $\times$ $\frac{1}{2}$ " long.
<b>Hub Bearings</b>	Front Cup and Cone : 20 balls $\frac{1}{8}$ " dia. Rear Journal : 15 $\times$ 42 $\times$ 13 mm. Sefeko 6302.
<b>Steering Head Bearings</b>	Top : 17 balls $\frac{1}{8}$ " dia. Bottom : 17 balls $\frac{1}{4}$ " dia.
<b>Wheel Rim Sizes</b>	Front and Rear : WMI 18.
<b>Tyre Sizes</b>	Front and rear : 3.00" $\times$ 18".
<b>Tyre Pressures — Solo Pillion</b>	Front 16 lbs. Rear 20 lbs. Front 16 lbs. Rear 28 lbs.
<b>Spokes</b>	Front N.S. (36) : $6\frac{5}{8}$ " $\times$ 12 swg. Front O.S. (36) : 7" $\times$ 12 swg. Nipples—front (36) : .225" $\times$ 12 swg. Rear (36) : $6\frac{5}{16}$ " $\times$ 10 swg. Nipples—rear (36) : .250" $\times$ 10 swg.
<b>Brake Drum Diameter</b>	Front 4" (10.16 cm.). Rear 5" (12.7 cm.).
<b>Total Braking Area</b>	11 $\frac{3}{4}$ sq. ins. (76 cm <sup>2</sup> ).
<b>Fuel Tank Capacity</b>	2 $\frac{1}{4}$ Imperial gallons (10.2 litres).
<b>Fuel Mixture</b>	One part recommended oil to 20 parts petrol. (4 filler cap measures of oil to one gallon petrol).
<b>Oil Capacity of Gearbox</b>	Approx. $\frac{1}{2}$ pint. Fill to oil level mark on dipstick.
<b>Oil Capacity of Primary Case</b>	Approx. $\frac{1}{2}$ pint. Fill to oil level plug.
<b>Speedometer</b>	Smiths magnetic type, illuminated.
<b>Speedometer Cable</b>	Rear wheel drive, length 4' 7".
<b>Wheelbase</b>	49 $\frac{1}{2}$ " (125.8 cm.).
<b>Seat Height</b>	29" (73.6 cm.).
<b>Ground Clearance</b>	5" (12.7 cm.).
<b>Width Over Bars</b>	26" (66 cm.).
<b>Overall Length</b>	76 $\frac{1}{2}$ " (194 cm.).
<b>Approx. Weight</b>	185 lbs. (84 kilos).



# GUARANTEE

**NOTICE**—We do not appoint agents for the sale on our behalf of our motor cycles or other goods, but we assign to motor cycle Dealers areas in which we supply to such Dealers exclusively for re-sale in such areas. No such Dealer is authorised to transact any business, give any warranty, make any representation or incur any liability on our behalf. Published retail prices are free of delivery free of charge at Dealers' premises. All goods are offered for sale subject to the price ruling at the time of delivery. All prices and specifications are subject to alteration without notice.

We give the following guarantee with our motor cycles, motor cycle combinations and sidecars, including all accessories and component parts other than tyres, saddles, chains and lighting and electrical equipment, and other than accessories and component parts supplied to the order of the Purchaser and differing from those comprised in the standard specifications supplied with our motor cycles, motor cycle combinations and sidecars, but including accessories and parts supplied by way of exchange as hereinafter provided. This guarantee is given in place of any implied conditions or warranties or any liabilities whatsoever statutory or otherwise; no guarantee except that hereinafter contained and no conditions or warranty whatsoever statutory or otherwise is given or is to be implied, nor are we to be under any liability whatsoever except under the guarantee hereinafter contained. Any statement, description, condition or representation contained in any catalogue, advertisement, leaflet or other publication shall not be construed as enlarging, varying or overriding anything herein contained. In the case of machines (a) which have been used for "hiring out" purposes or (b) any motor cycle and/or sidecar used for any dirt track, cinder track or grass track racing or competitions (or any competition of any kind within an enclosure for which a charge is made for admission to take part in or view the competition) or (c) machines from which the trade mark, name or manufacturing number has been altered or removed or (d) any machines in which parts have been used not supplied by or approved by the motor cycle manufacturer or (e) any machine from which the silencing system as fitted by the manufacturer has been partially or wholly removed or interfered with, no guarantee, condition or warranty of any kind statutory or otherwise, is given or is to be implied, nor are we to be under any liability whatsoever in respect of any such machine. We guarantee, subject to the conditions mentioned below, that all precautions which are usual and reasonable have been taken by us to secure excellence of materials and workmanship, but this guarantee is to extend and be in force for six months only in U.K. and ninety days overseas from date of purchase, or date of exchange in case of any accessory or part supplied by way of exchange as hereinafter provided, and damages for which we make ourselves responsible under this guarantee are limited to the free repair of or supply of a new part or accessory in exchange for the part of the motor cycle, motor cycle combination or sidecar or accessory which may have proved defective. We undertake, subject to the conditions mentioned below, to make good in manner aforesaid any part or accessory covered by this guarantee which has proved defective within the said period. We do not undertake to replace or refix or bear the cost of replacing or refixing any such new part or accessory in the motor cycle, motor cycle combination or sidecar. As motor cycles, motor cycle combinations and sidecars are easily liable to derangement by neglect or misuse, this guarantee does not apply to defects caused by wear and tear, misuse or neglect.

The term "misuse" shall include, amongst others, the following acts:

1. The attaching of a sidecar to a motor cycle in such a manner as to cause damage or calculated to render the latter unsafe when ridden.
2. The use of a motor cycle or of a motor cycle and sidecar combined, when carrying more persons or a greater weight than that for which the machine was designed by the manufacturers.
3. The attaching of a sidecar to a motor cycle by any form of attachment not provided, supplied or approved by the manufacturers, or to a motor cycle which is not designed for such use.

We do not guarantee tyres, saddles, chains or lighting and electrical equipment, or any accessories or component parts supplied to the order of the Purchaser differing from those comprised in the standard specifications supplied with our motor cycles, motor cycle combinations or sidecars. As regards all such tyres, saddles, chains, lighting and electrical equipment, accessories and component parts, no guarantee, condition or warranty of any kind statutory or otherwise is given or is to be implied, and we are to be under no liability whatsoever in respect thereof.

**CONDITIONS OF GUARANTEE**—If a defective part or accessory should be found in our motor cycles, motor cycle combinations or sidecars, or in any part or accessory supplied by way of exchange as before provided, it must be sent to us **CARRIAGE PAID** and accompanied by an intimation from the owner that he desires to have it repaired or exchanged free of charge under our guarantee, and he must also furnish us at the same time with the frame number of the machine, the date of purchase or the date when the alleged defective part or accessory was exchanged as the case may be.

Failing compliance with the above, such articles will lie here at **THE RISK OF THE OWNER**, and this guarantee and any implied guarantee, warranty or condition shall not be enforceable.

**REPAIRS**—Any motor cycle, motor cycle combination or sidecar sent to us to be plated, enamelled or repaired will be repaired upon the following conditions, *i.e.*, we guarantee that all precautions which are usual and reasonable have been taken by us to secure excellence of materials and workmanship, such guarantee to extend and be in force for three months only from the time such work shall have been executed, and this guarantee is in lieu and in exclusion of all conditions and warranties statutory or otherwise, and all liabilities whatsoever and the damages recoverable are limited to the cost of any further work which may be necessary to amend and make good the work found to be defective.





James Publication No. L1 / L15 / 58 / 7½M  
February, 1958

PRINTED IN ENGLAND



# IceniCAM Information Service

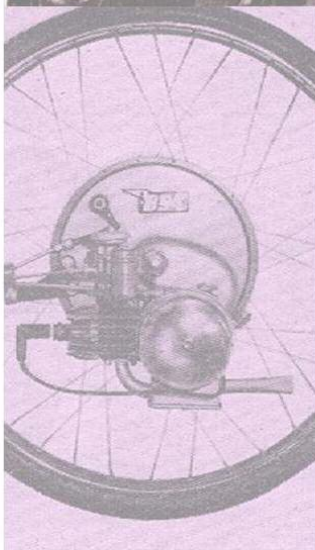

[www.icenicam.org.uk](http://www.icenicam.org.uk)