SPARE PARTS LIST

FOR

JAMES

1952 - 53

122 cc MODEL J6 CADET DE LUXE

197 cc MODEL J7 CAPTAIN

197 cc MODEL J8 CAPTAIN DE LUXE

197 cc MODEL J9 COMMANDO

MANUFACTURERS:

THE JAMES CYCLE CO., LTD.

GOUGH ROAD

BIRMINGHAM, 11 :: ENGLAND

DECEMBER, 1953

PRICE 2/6

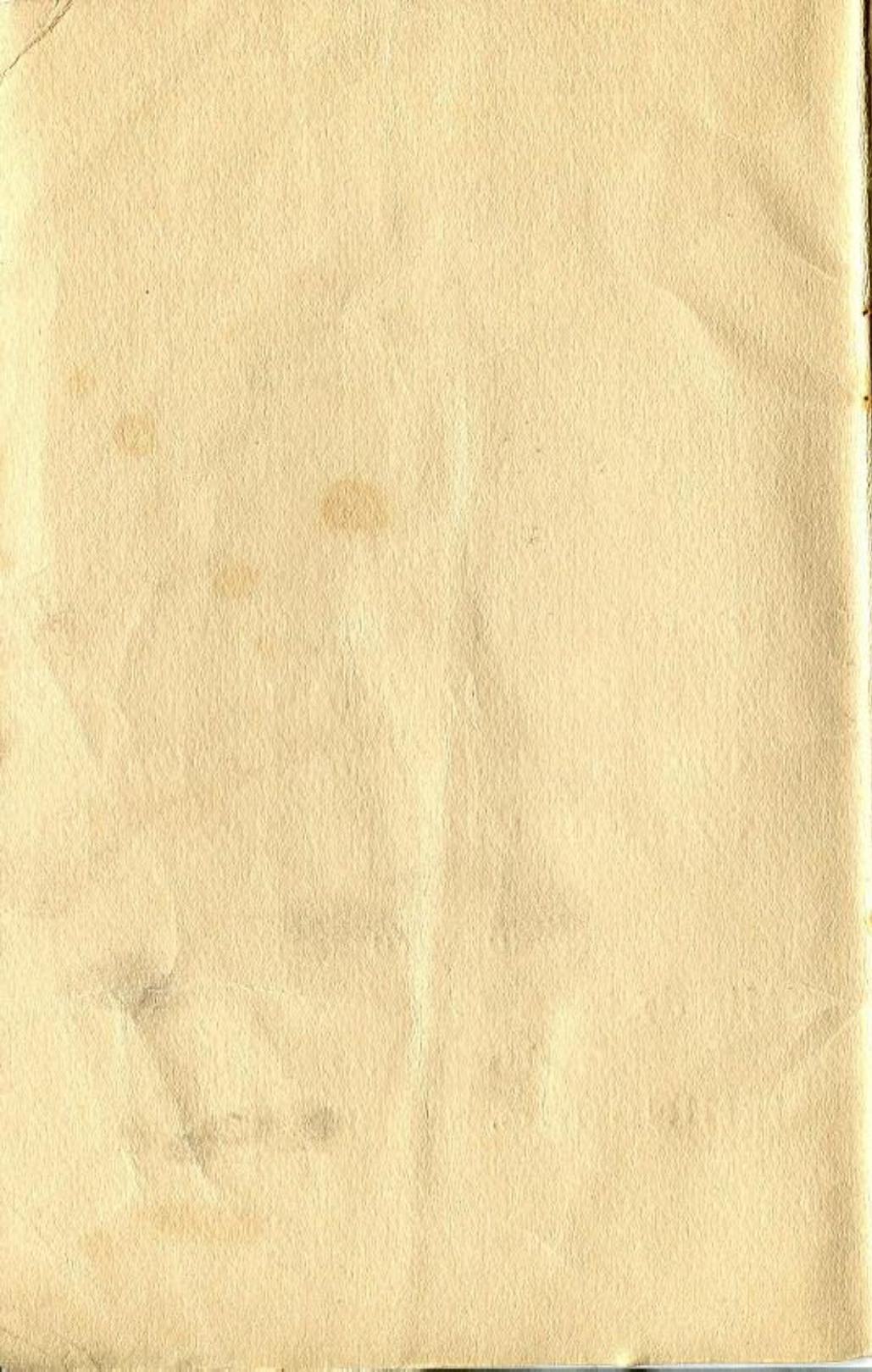

SPARE PARTS LIST

FOR

JAMES

1952 - 53

122 cc MODEL J6 CADET DE LUXE

197 cc MODEL J7 CAPTAIN

197 cc MODEL J8 CAPTAIN DE LUXE

197 cc MODEL J9 COMMANDO

Manufacturers :

**THE JAMES CYCLE COMPANY, LIMITED
GOUGH ROAD, BIRMINGHAM, 11, ENGLAND**

Telegrams:

"BICYCLES BIRMINGHAM"

Telephone :

VICToria 2211 (5 lines)

Nearest Railway Station
BIRMINGHAM, SMALL HEATH
BRITISH RAILWAYS, WESTERN REGION

CONTENTS

	<i>Page</i>
Additional equipment	20
Brakes	12, 13, 14, 15
Carrier	6, 7
Carburetter	30, 31, 32, 33
Chains	22, 24, 26, 28
Chainguard	10, 11
Clutch	22, 24, 26, 28
Controls	18, 19, 20
Engine 197cc	22, 23, 24
Engine 122cc	26, 27, 28
Exhaust system	16, 17
Flywheel magneto	29
Footrests	5, 6
Forks	7, 8, 9
Frame	5, 6, 7
Fuel tank	16, 17
Gearbox, 3 speed... ..	33, 34, 35
Gearbox, 4 speed... ..	36, 37
Handlebars	18, 19, 20
Hubs	12, 13, 14, 15
Lighting equipment	18, 19
Mudguards	10, 11, 12
Number plates	10, 11
Rear suspension	8, 9
Saddle	16, 17
Silencer	16, 17
Speedometer	16, 17
Spokes	14
Stand	5, 6
Steering stem	7, 8
Tools	19, 20
Toolbox	10, 11
Wheels	12, 13, 14, 15

Spares and Repairs

For the convenience of owners, James Spares Stockists are appointed for most districts and customers are recommended to always apply to their nearest stockist. A list of stockists can be obtained on application (please enclose stamped and addressed envelope for reply).

When ordering spare parts always quote the full part number and description, as well as the engine and frame number of the machine. Most parts are clearly illustrated in this list, but if in any doubt owners are advised to produce the original part as pattern, and to quote their full engine and frame numbers to enable identification.

Instructions regarding repairs should be clear and definite, otherwise the cost may be greater than expected. We shall be pleased to give estimates for repairs if parts are sent to us for that purpose. If the estimate is accepted, no charge will be made for the preliminary examination, but should the owner decide not to have the work carried out, a nominal charge may be made to cover the cost of whatever work may have been done to prepare the estimate. Parts sent to us as patterns or for repairs, should have attached to them a label with the sender's full name and address. Instructions regarding such parts should be sent separately.

Customers wishing to retain old parts which are replaced during overhaul or repair, should state so before work commences, as normally such parts are scrapped upon removal.

If it is necessary to bring a machine, or parts, to the works for an urgent repair, it is essential that an appointment be made beforehand. This can be done by letter or telephone, and will avoid disappointment.

Orders should always be sent in list form and not as part of a letter.

When writing on a technical matter always quote your engine and frame numbers. A space is provided below for easy reference.

MODEL No.	
ENGINE NUMBER	FRAME NUMBER

NOTE : Due to varying costs of raw materials, we reserve the right to alter any of the prices quoted in this list, without notice.

THE JAMES SPARES AND SERVICE DEPARTMENT

HOURS OF BUSINESS FOR CALLERS :

8.30 a.m. to 12.30 p.m. 1.30 p.m. to 5.30 p.m.

MONDAYS TUESDAYS WEDNESDAYS

THURSDAYS FRIDAYS

(Not Open on National Holidays)

— HOW TO GET THERE —

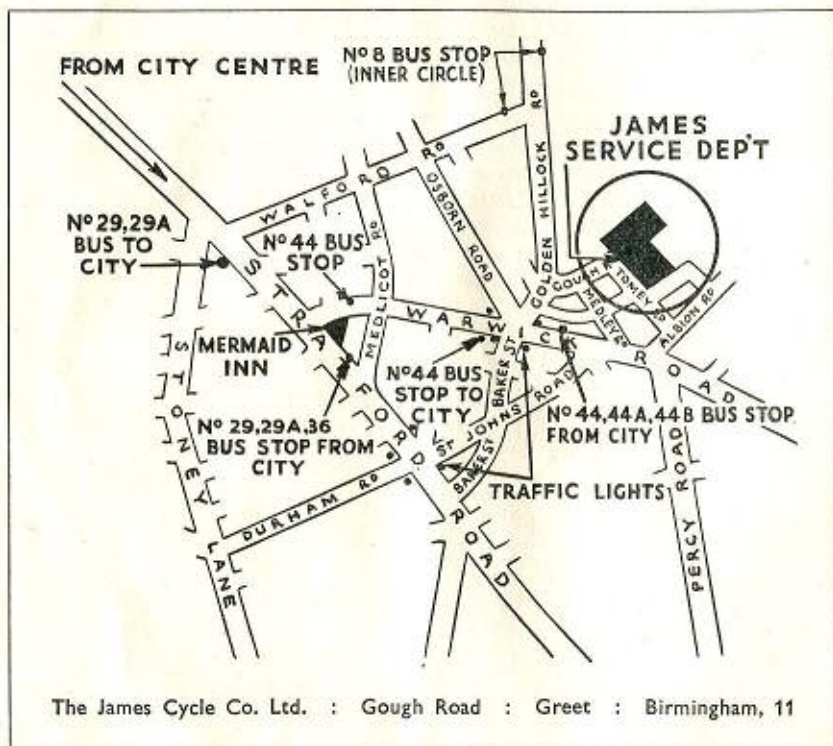

IMPORTANT

PLEASE NOTE THAT ALL PRICES OF SPARES FOR VILLIERS ENGINE, MAGNETO, CARBURETTER, GEARBOX AND LIGHTING EQUIPMENT IN THIS LIST ARE SUBJECT TO 30% INCREASE UNTIL FURTHER NOTICE.

The James Cycle Co. Ltd.

December, 1953

FRAME ASSEMBLY—INCLUDING STAND, FOOTRESTS, BRAKE PEDAL, ENGINE BOLTS, ETC. (See illustrations page 6)

NOTE : Model numbers have been abbreviated by omitting prefix letter "J," viz. : Model 8 = Model J8 Captain De Luxe.

Ill. No.	Model No.	Description of Part	Qty	Part No.	Price Each £ s. d.
1	6-7-8	Frame front assembly	1	001036	5 15 0
2	9	" " " — comp.	1	001201	8 8 0
3	7	" " rear section — rigid	1	001037	2 15 0
4	6-8	" " " spring	1	000984	5 5 0
5	9	" " " comp. rigid	1	001202	4 4 0
6	All	Bolt tube, chain stay	1	001248	4 0 0
7	All	" " plain washer $\frac{3}{8}$ " dia.	2	900184	1 1
8	All	" " hex nut $\frac{3}{8}$ " x 20 t.p.i.	2	900182	6
9	6-7-8	Stud double ended seat stays $5\frac{1}{8}$ " long	1	900183	1 0
10	9	" " " " $5\frac{3}{8}$ " "	1	900031	1 0
11	All	Plain washer $\frac{7}{16}$ " dia.	2	900033	1
12	All	Hex nut $\frac{7}{16}$ " x 26 t.p.i.	2	900034	1 9
13	All	Frame ball race	2	001007	4
14	All	Enclosure cup, bottom race	1	001011	1 9
15	All	Saddle and tank bolt $\frac{5}{16}$ " x 26 t.p.i.	1	900041	3
16	All	Plain washer $\frac{5}{16}$ " dia.	2	900009	1
17	6-7-8	Pivot bush — saddle	2	001060	9
18	9	" " " "	2	000854	9
19	6-7-8	Plain washer $\frac{1}{8}$ " x 18 s.w.g.	2	900170	3
20	All	Hex nut — pivot bush $\frac{1}{8}$ " x 26 t.p.i.	1	900000	2
21	All	Engine bolts $\frac{3}{8}$ " x 20 t.p.i.	3	900040	1 0
22	All	Plain washer $\frac{3}{8}$ " dia.	3	900011	1
23	All	Shakeproof washer $\frac{3}{8}$ " dia.	3	900002	1
24	All	Hex nut $\frac{3}{8}$ " x 20 t.p.i.	3	900017	2
25	All	Tank front fixing bolt $\frac{3}{8}$ " x 20 t.p.i.	1	900073	4
26	All	Plain washer $\frac{3}{8}$ " dia.	2	900011	1
27	All	Distance tube	1	000510	4
28	6-7-8	Pump peg	1	—	—
29	All	Shakeproof washer	1	900002	1
30	All	Hex nut $\frac{3}{8}$ " x 20 t.p.i.	1	900017	2
31	6-7-8	Pump clip and fixing screw	1	000609	1 0
32	All	Footrest rod — square	1	000215	2 6
33	6-7-8	Centre stand bracket — R.H.	1	000790	3 6
34	6-7-8	" " " " L.H.	1	000791	3 6
35	6-7-8	Distance tube $1\frac{1}{2}$ " long	2	000220	5
36	6-7-8	Footrest hanger	2	002156	3 0
37	6-7-8	" " rubber — open ended	2	000222	1 6
—	6-7-8	" " " " dumbbell type	2	002026	1 6
38	6-7-8	Plain washer $\frac{1}{2}$ " dia.	4	900137	1
39	6-7-8	Hex nut $\frac{3}{8}$ " x 26 t.p.i.	2	900021	2
40	All	Plain washer $\frac{3}{8}$ " dia.	2	900014	1
41	All	Hex nut $\frac{3}{8}$ " x 26 t.p.i.	2	900034	3
42	9	Footrest support — short	1	001572	8 0
43	9	" " " " long	1	001573	8 0
44	9	Double ended stud $\frac{1}{2}$ " x 26 t.p.i.	1	900097	2 6
45	9	Plain washer $\frac{1}{2}$ " dia.	2	900030	1
46	9	Hex nut $\frac{1}{2}$ " x 26 t.p.i.	2	900057	3
47	9	Footrest hanger	2	002152	7 6
48	6-7-8	Centre stand — pressed steel	1	000917	16 6
—	6-7-8	" " " " tubular	1	002020	10 6
49	6-7-8	Pivot bolt	2	000227	9
50	6-7-8	Plain washer $\frac{3}{8}$ " dia.	2	900014	1
51	6-7-8	Shakeproof washer $\frac{3}{8}$ " dia.	2	900002	1
52	6-7-8	Hex nut $\frac{3}{8}$ " x 20 t.p.i.	2	900063	7
53	6-7-8	Stand return spring	2	000229	1 0
54	6-7-8	Rear brake pedal	1	001062	12 6
—	9	" " " "	1	001576	11 0

**FRAME ASSEMBLY—INCLUDING STAND, FOOTRESTS, BRAKE PEDAL.
ENGINE BOLTS, ETC. (See pages 5 and 7)**

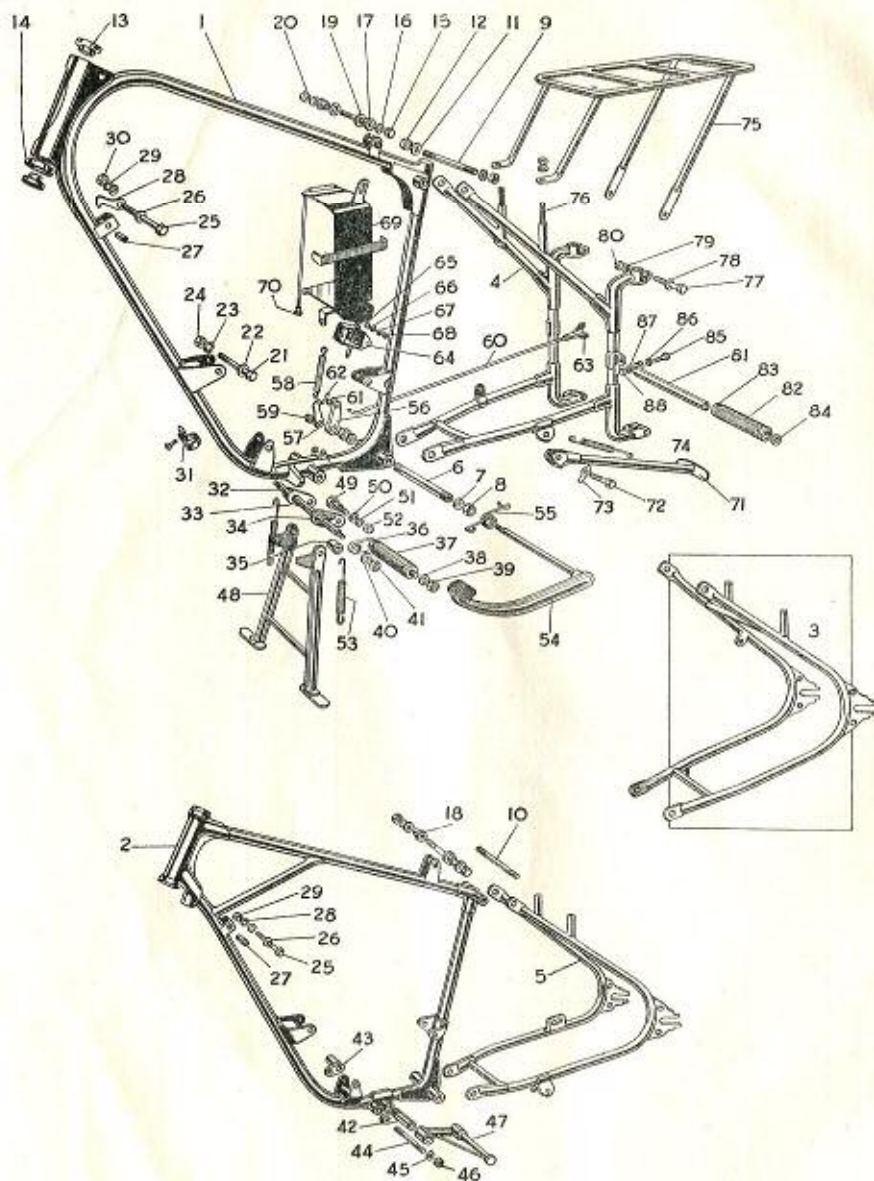

Always quote your full engine and frame numbers as well as part numbers, when ordering replacement parts

IT PAYS TO FIT GENUINE "JAMES" COMPONENTS

TELESCOPIC FORKS — REAR SUSPENSION

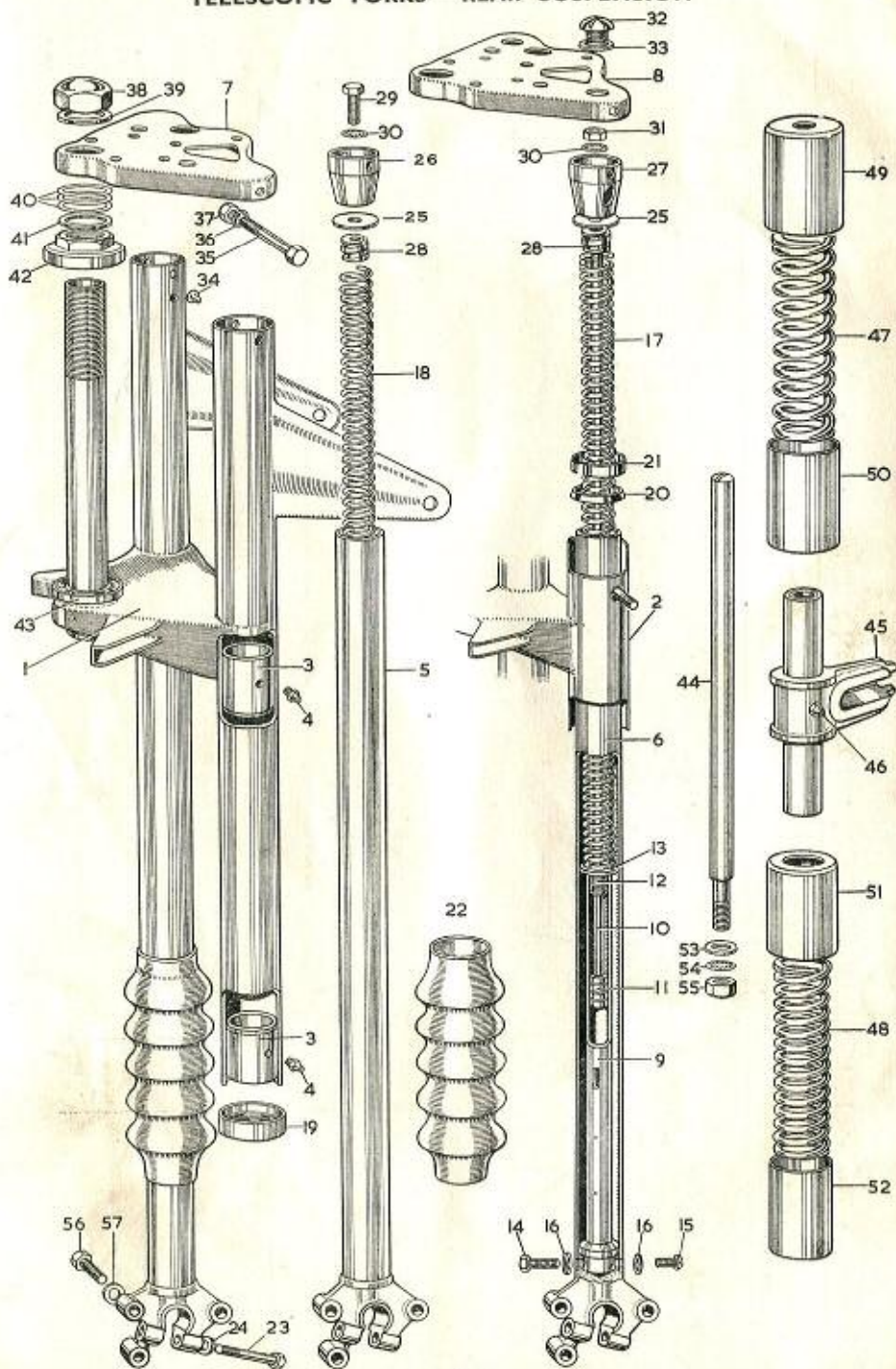

TELESCOPIC FORKS & REAR SUSPENSION UNITS — continued

Ill. No.	Model No.	Description of Part	Qty.	Part No.	Price Each £ s. d.
10	9	Piston rod — damper	2	001561	5 0
11	9	Piston	2	001562	2 0
12	9	Spring adaptor — bottom	2	001563	2 6
13	9	Space washer	2	001564	9
14	9	Hex bolt $\frac{1}{4}$ " x 26 t.p.i.	2	900054	4
15	9	Round head screw	2	900088	2
16	9	Special sealing washer	4	900102	3
17	9	Main coil spring — 2 rate	2	001423	10 0
18	6-7-8	" " " — 3 "	2	001500	8 6
19	All	Oil seal outer tube — bottom	2	001422	2 6
20	9	" " " — top	2	001714	2 6
21	9	Circlip for top oil seal	2	000194	6
22	All	Fork gaiter — plastic	2	001682	pair 6 0
23	All	Pinch bolt, for end $\frac{5}{16}$ " BSF	2	900180	3
24	All	" " plain washer	2	900009	1
25	All	Seating washer	2	900079	1
26	6-7-8	Top cup spring support	2	001499	2 0
27	9	" " "	2	001545	2 0
28	All	Spring adaptor — top	2	001001	2 6
29	6-7-8	Fixing bolt $\frac{5}{16}$ " BSF	2	900181	1
30	6-7-8	" " shakeproof washer	2	900003	1
31	9	Fixing nut $\frac{5}{16}$ " BSF	2	900103	2
32	9	Filler plug	2	900109	9
33	9	" " fibre washer $\frac{1}{2}$ " dia.	2	000165	4
34	9	Rubber vent plug	2	001443	3
35	All	Hex bolt $\frac{1}{4}$ " x 26 t.p.i. x 2"	2	900178	3
36	All	Shakeproof washer $\frac{1}{2}$ " dia.	2	900004	1
37	All	Hex nut $\frac{1}{4}$ " x 26 t.p.i.	2	900027	1
38	All	Steering stem nut	1	001530	2 6
39	All	Plain washer 1" dia. thick	1	000122	2
40	All	Adjusting shims .005"	3	001013	1
41	All	Plain washer 1" x 16 swg.	1	900179	1
42	All	Adjusting race	1	001012	1 9
43	All	Fork crown race	1	001008	2 0
	All	Ball bearings $\frac{1}{4}$ " dia.	34	000371	set 1 6
44	6-8	Central guide rod	2	000088	3 0
45	6-8	Fork end — near side	1	000967	1 10 0
	6-8	" " — off side	1	000968	1 15 0
46	6-8	Grease nipple $\frac{1}{4}$ " x 26 t.p.i.	4	000106	4
47	6-8	Main load spring	2	000089	4 6
48	6-8	Recoil spring	2	000090	3 6
49	6-8	Main spring top cover	2	000091	3 6
50	6-8	" " bottom cover	2	000094	5 0
51	6-8	Recoil spring top cover	2	000097	3 6
52	6-8	" " bottom cover	2	000100	4 6
53	6-8	Plain washer — guide rod	2	900033	1
54	6-8	Shakeproof washer — guide rod	2	900005	1
55	6-8	Hex nut $\frac{1}{8}$ " x 26 guide rod	2	900034	3
56	All	Mudguard stay fixing bolt	6		3
57	All	" " " " washer	6		1

NOTE : Due to varying costs of raw materials, we reserve the right to alter any prices, without notice.

MUDGUARDS — CHAINGUARDS AND FITTINGS

III. No.	Model No.	Description of Part	Qty.	Part No.	Price Each £ s. d.
1	7	Front mudguard with front & back stays	1	001197	1 1 0
2	6-7-8	Centre stay — L.H.	1	001198	1 6
3	6-7-8	" " R.H.	1	001199	1 6
4	All	Fork stay fixing bolt $\frac{1}{8}$ " BSF	6	900181	3
5	All	Plain washer $\frac{3}{8}$ " dia.	6	900009	1
6	All	Mudguard stay hex bolt $\frac{1}{4}$ " x 26 t.p.i. ...	—	900046	2
7	All	Plain washer $\frac{1}{4}$ " dia.	—	900008	2
8	All	Shakeproof washer $\frac{1}{4}$ " dia.	—	900004	1
9	All	Hex nut $\frac{1}{4}$ " x 26 t.p.i.	—	900027	1
10	All	Front number plate	1	000431	1 6
11	All	Round head screw $\frac{3}{8}$ " x 26 t.p.i.	2	900010	1
12	All	Shakeproof washer $\frac{3}{8}$ " dia.	2	900006	1
13	All	Hex nut $\frac{3}{8}$ " x 26 t.p.i.	2	900016	2
14	All	Number plate bracket and bolt	2	000158	1 0
15	All	" " plain washer	2	900043	doz. 6
16	All	" " hex nut	2	900042	1
17	6-8	Front mudguard with front and rear stays	1	001316	18 0
18	6-8	Decorative motif	1	000423	†
19	9	Front mudguard — polished alloy	1	001497	1 10 0
20	9	Front stay	1	001679	2 6
21	9	Centre stay	1	001677	10 0
22	9	Rear stay	1	001680	2 6
23	7	Toolbox and lid screw	1	000739	14 0
24	All	Lid thumb screw	1	000641	1 6
25	6-8	Triangular toolbox and lid screw	1	000333	14 0
26	9	Toolbox and lid screw	1	002023	1 6
27	9	Fixing clip	1	000537	6
28	9	Fibre distance piece	2	000424	2
29	9	Hex bolt $\frac{1}{4}$ " x 26 x $\frac{7}{8}$ "	2	900024	2
30	9	Plain washer $\frac{1}{4}$ " dia.	2	900008	1
31	9	Hex nut $\frac{1}{4}$ " x 26 t.p.i.	2	900027	1
32	7	Chainguard	1	001578	10 6
33	All	Wings transfer	1	000665	1 6
34	6-8	Chainguard	1	000959	10 6
35	9	" "	1	001612	12 6
36	7	Rear mudguard with centre stays	1	001440	18 0
37	7	Detachable rear stay	1	001442	2 6
38	6-7-8	Rear number plate	1	000737	10 0
—	9	" "	1	001864	10 0
39	All	Fibre distance piece	1	000429	4
40	All	Hex bolt $\frac{1}{4}$ " x 26 x 1"	1	900025	2
41	6-7-8	" " $\frac{1}{4}$ " x 26 x $\frac{7}{8}$ "	2	900024	2
42	6-8-9	" " $\frac{1}{4}$ " x 26 x $\frac{5}{8}$ "	4	900054	4
43	7-9	" " $\frac{1}{4}$ " x 26 x $\frac{3}{8}$ "	—	900046	2
44	All	Plain washer	—	900008	1
45	All	" " large	—	900045	2
46	All	Shakeproof washer	—	900004	1
47	All	Hex nut $\frac{1}{4}$ " x 26 t.p.i.	—	900027	1
48	6-8	Rear mudguard — valanced	1	001315	17 6
49	6-8	Stay tube — L.H.	1	000946	4 6
50	6-8	" " R.H.	1	000947	4 6
—	6-8	Cable cover strip	1	000415	2 3
—	6-8	Self tapping screw	3	900152	doz. 6
51	9	Rear mudguard — polished alloy	1	001496	2 10 0
52	9	Bridge strap	1	001607	1 6
53	9	Lifting handle	2	001230	5 0
54	9	Centre stay — L.H.	1	001599	2 6
55	9	" " R.H.	1	001600	2 6
56	9	Rear detachable stay	2	001603	2 6

† No longer available

MUDGUARDS — CHAINGUARDS AND FITTINGS

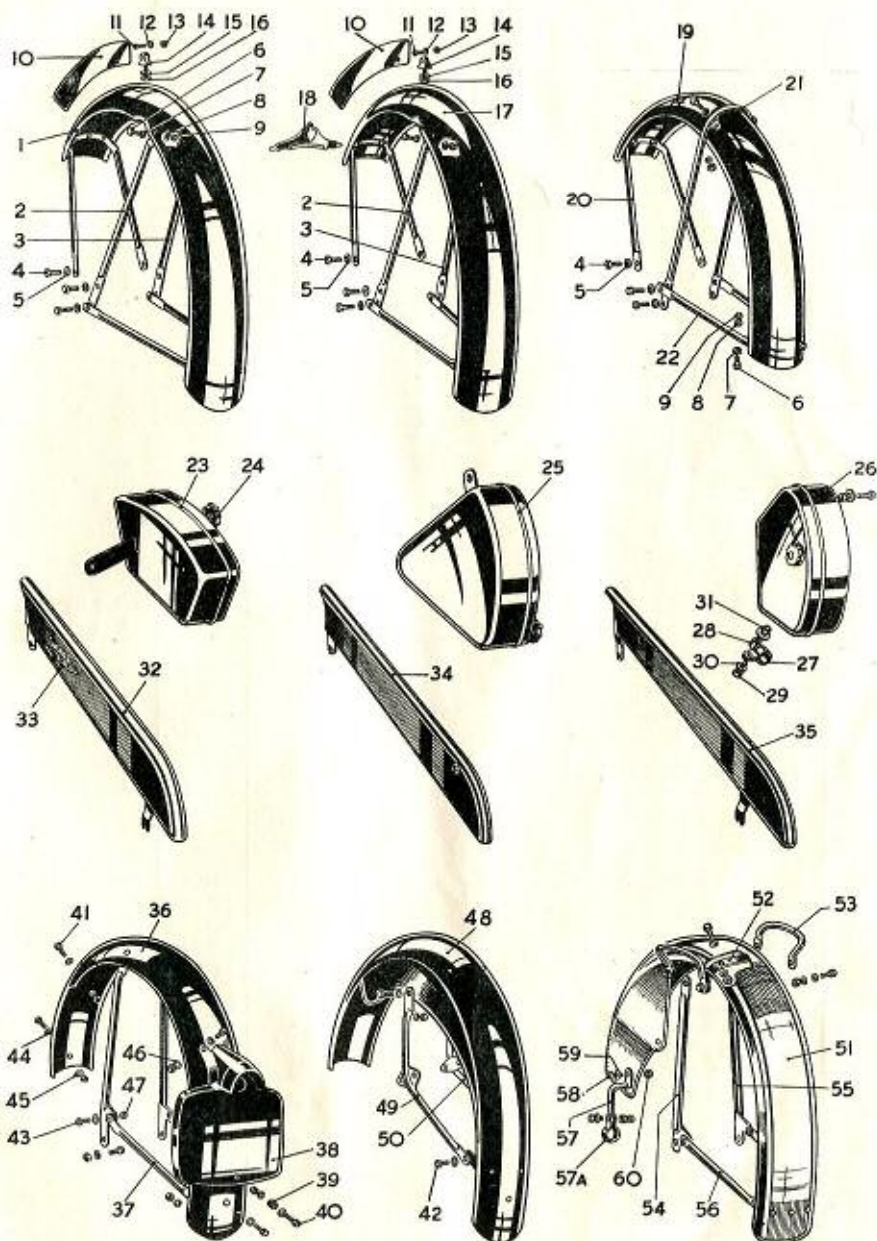

IT PAYS TO FIT GENUINE "JAMES" COMPONENTS

MUDGUARDS — CHAINGUARDS AND FITTINGS — continued

Ill. No.	Model No.	Description of Part	Qty.	Part No.	Price Each £ s. d.
57	9	Valance attachment bracket	1	001619	1 6
57a	9	clip	1	000537	6
58	9	Round headed screw $\frac{3}{16}$ " \times 26	1	900010	2
59	9	Plain washer $\frac{3}{16}$ " dia.	1	900022	1
60	9	Hex nut $\frac{3}{16}$ " \times 26 t.p.i.	1	900027	1

FRONT HUB

Models J6 — J7 — J8 — J9

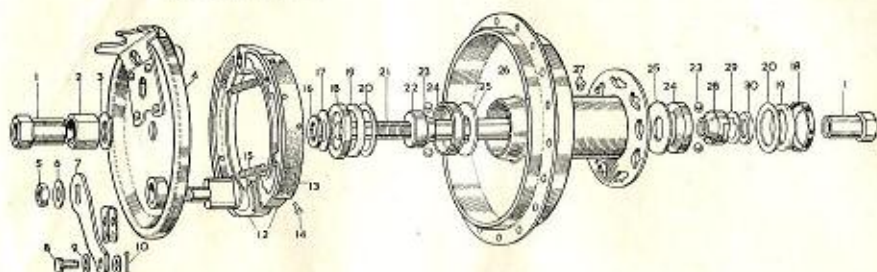

Ill. No.	Description of Part	Qty.	Part No.	Price Each £ s. d.
1	Spindle nut	2	900172	6
2	Backplate locknut — recessed	1	900173	4
3	washer	1	900001	2
4	Backplate	1	001091	12 6
5	Brake cam nut	1	900000	2
6	" " washer	1	900166	2
7	" " lever	1	000929	2 0
8	" " pivot pin	1		2
9	" " washer	2		1
10	" " split pin	1		1
11	" " and washer	1	001088	4 0
12	Brake shoe	2	000901	pair 12 6
13	" lining	2	000314	4 6
14	" rivet	14	900145	set 6
15	" return spring	2	000320	5
16	Distance piece	1	000312	4
17	Plain washer	1	900170	3
18	Dustcap	2	000942	6
19	Felt washer	2	000941	3
20	Enclosure washer	2	000940	3
21	Spindle	1	000949	4 9
22	Fixed cone	1	000306	2 6
23	Ball bearings, $\frac{5}{16}$ "	20	000311	set 1 0
24	Bearing cup	2	000303	2 0
25	Seating washer	2	000304	2
26	Hub shell and brake drum	1	001071	1 8 0
27	Grease nipple	1	000106	4
28	Adjusting Cone	1	000307	2 9
29	Tab lock washer	1	000310	2
30	Locknut	1	900058	2

REAR HUB

Model J6 — J7 and J8

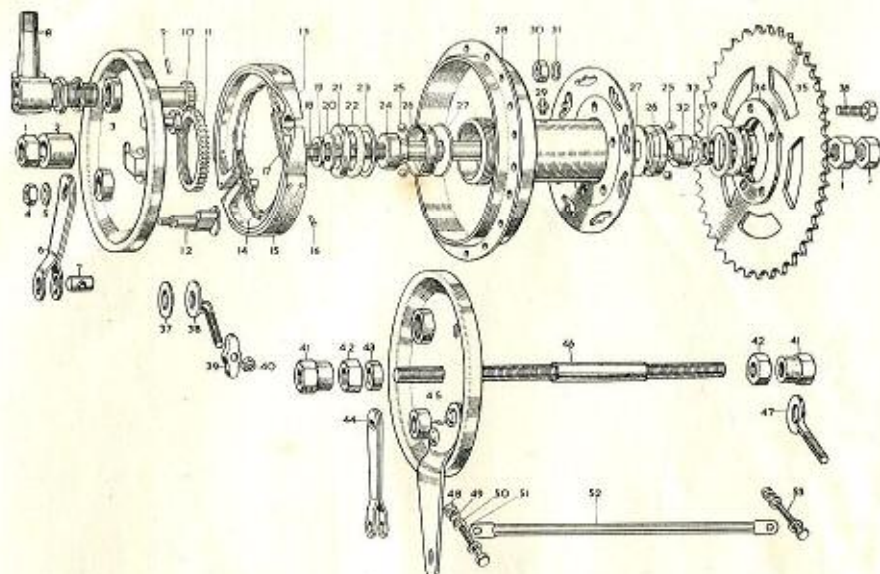

Ill. No.	Description of Part	Qty.	Part No.	Price Each £ s. d.
1	Spindle nut	3	900057	3
2	Distance piece	1	000337	2
3	Backplate	1	000944	15 6
4	Brake cam lever nut	1	900000	2
5	" " washer	1	900166	2
6	" " lever	1	000825	2 6
7	" " roller	1	000341	7
8	Speedo drive gearbox	1	000590	1 17 6
9	" " pinion rivet	1	900169	2
10	" " " 15T	1	000591	4 6
11	" " gear ring 44T	1	000592	13 0
12	Brake cam	1	001088	4 0
13	" shoe — upper	1	000900	} pr. 12 6
14	" " lower	1	000899	
15	" lining	2	000314	4 6
16	" " rivet	14	900145	set 6
17	" return spring	2	000320	5
18	Spindle $\frac{1}{2}$ " dia.	1	000826	5 0
19	Distance piece	2	000312	4
20	Plain washer	1	900170	3
21	Dustcap	2	000942	6
22	Felt washer	2	000941	3
23	Enclosure washer	2	000940	3
24	Fixed cone	1	000306	2 6
25	Ball bearings $\frac{3}{8}$ "	20	000311	set 1 0
26	Bearing cup	2	000303	2 0
27	Seating washer	2	000304	2
28	Hub shell	1	001080	1 10 0
29	Grease nipple	1	000106	4
30	Sprocket nut...	5	900000	2

REAR HUB.

Model J9 Competition machine

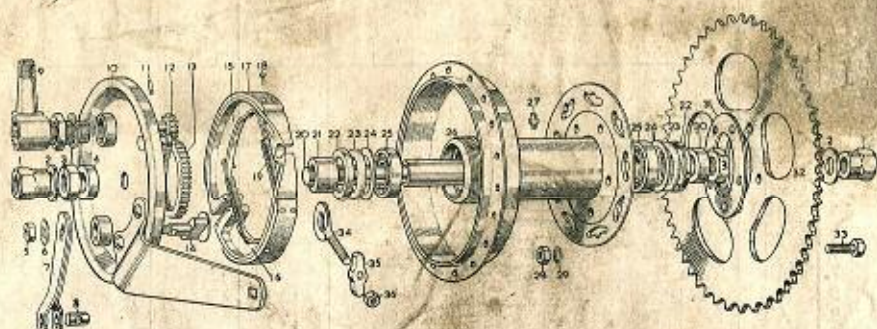

Ill. No.	Description of Part	Qty.	Part No.	Price Each £ s. d.
1	Spindle nut	2	900047	1 0
2	Plain washer	2	900115	1 1
3	Locknut	2	900051	3
4	Distance piece	1	001337	9
5	Brake cam nut	1	900000	2
6	" lever washer	1	900166	2
7	" lever	1	000825	2 6
8	" roller	1	000341	7
9	Speedo drive gearbox	1	000590	1 17 6
10	Backplate	1	001338	15 6
11	Speedo pinion rivet	1	900169	2
12	" 14T	1	001930	4 6
13	" gear ring 45T	1	001931	13 0
14	Brake cam	1	001088	4 0
15	Brake shoe — upper	1	000900	12 6
16	" lower	1	000899	pair
17	" lining	2	000314	pair 4 6
18	" rivet	14	900145	set 6 6
19	Return spring	2	000320	5
20	Spindle $\frac{1}{8}$ " dia.	1	001332	9 0
21	Distance piece	1	001336	9
22	Dustcap	2	000942	6
23	Felt washer	2	000941	3
24	Enclosure washer	2	000940	3
25	Journal bearing	2	001333	*
26	Hub shell and brake drum	1	001594	1 10 0
27	Grease nipple	1	000106	4
28	Sprocket nut...	5	900000	2
29	" shakeproof washer	5	900003	1
30	Distance piece	1	001335	9
31	Distance ring $\frac{1}{4}$ " thick	1	001330	2 6
32	Rear sprocket 52 teeth	1	001152	15 0
33	" bolt	5	900055	3
34	Chain adjuster	2	001329	9
35	" cap	2	000600	3
36	" nut	2	900027	1
—	Rear sprocket 50 teeth	—	001150	15 0

* Manufacturers' current price

TANK—SPEDO—ELECTRIC HORN—SADDLES—EXHAUST SYSTEM

Ill. No.	Model No.	Description of Part	Qty.	Part No.	Price Each £ s. d.
1	7	Fuel tank	1	001404	6 6 0
—	6-8	Fuel tank with knee grip plates	1	001403	6 6 0
—	9	Fuel tank	1	001616	6 6 0
2	All	Tank top strip — maroon	1	000639	5 0
—	All	" " " chromed	1	000638	6 6
3	All	Self tapping screw	2	900153	doz. 1 6
4	All	Mush head screw 3BA	2	900156	5
5	All	Filler cap	1	000720	6 6
6	All	Filler cap fibre washer	1	900161	3
7	All	Tank " wings " transfer	2	000665	1 6
8	6-8	Rubber knee grip	2	000513	pair 9 6
9	All	Petrol tap and filter	1	000767	5 6
10	6	" pipe complete	1	000844	4 6
—	7-8	" " "	1	000498	5 0
—	9	" " "	1	001614	4 6
—	7-8-9	Plastic fuel pipe 4½" long	1	002180	1 6
—	All	Fuel pipe ferrule	2	002063	1 6
—	All	Petrol tap for plastic pipe	1	001999	5 6
—	All	Banjo union for plastic pipe	1	002000	1 9
11	All	Drain plug	1	900158	3
12	All	Fibre washer	1	900144	1
—	6	55 m.p.h. speedo head	1	000588	2 15 6
—	6	90 k.p.h. speedo head	1	000630	3 10 6
13	7-8-9	65 m.p.h. speedo head	1	000589	3 10 0
—	7-8-9	110 k.p.h. speedo head	1	000631	3 10 0
14	All	Speedo spring washer	2	900142	1 1
15	All	" hex nut	2	900130	1
16	6-8	Lightweight electric horn	1	000329	18 6
17	6-7-8	Saddle frame & cover with nuts & bolts... ..	1	000576	2 5 0
18	6-7-8	Springs 6½" long	2	001968	2 6
19	9	Saddle — rubber competition	1	001210	3 12 0
20	9	Springs 5½" long	2	000645	2 6
21	6-8	Silencer complete	1	001501	1 15 0
—	7-9	" " "	1	001224	1 15 0
22	6-8	" body	1	001502	15 0
—	7-9	" " "	1	000848	15 0
23	All	" chamber and tail pipe	1	000849	12 6
—	All	Glass wool filling	—	000643	¼lb. 2 6
—	All	Self tapping screw	4	900155	1
24	6	Exhaust pipe	1	001493	1 10 0
—	7	" " "	1	000521	1 10 0
—	8	" " "	1	001494	1 10 0
—	9	" " "	1	001587	2 0 0
25	All	Silencer clip	1	000475	2 3
26	All	Hex bolt ½" x 26 t.p.i.	1	900075	3
27	All	Plain washer	1	900008	1
28	All	Shakeproof washer	1	900004	1
29	All	Hex nut ½" x 26 t.p.i.	1	900027	1
30	6-8	Adaptor bolt ⅝" x 26 t.p.i.	1	000951	2 0
31	6-8	Hex bolt ⅝" x 26 t.p.i.	1	900059	4
32	6-8	Plain washer	4	900044	2
33	6-8	Shakeproof washer	2	900003	1
34	6-8	Hex nut ⅝" x 26 t.p.i.	1	900000	2
—	7	Tail pipe clip	1	000472	2 0
—	7	Hex bolt ⅝" x 26 t.p.i.	1	900041	4
—	9	Tail pipe clip	1	001588	3 0
—	9	Hex bolt ⅝" x 26 x 2⅜" long	1	900119	2
—	9	Plain washer ⅝" dia.	1	900044	2
—	9	Hex nut ⅝" x 26 t.p.i.	1	900000	2

TANK—SPEEDO—ELECTRIC HORN—SADDLES—EXHAUST SYSTEM

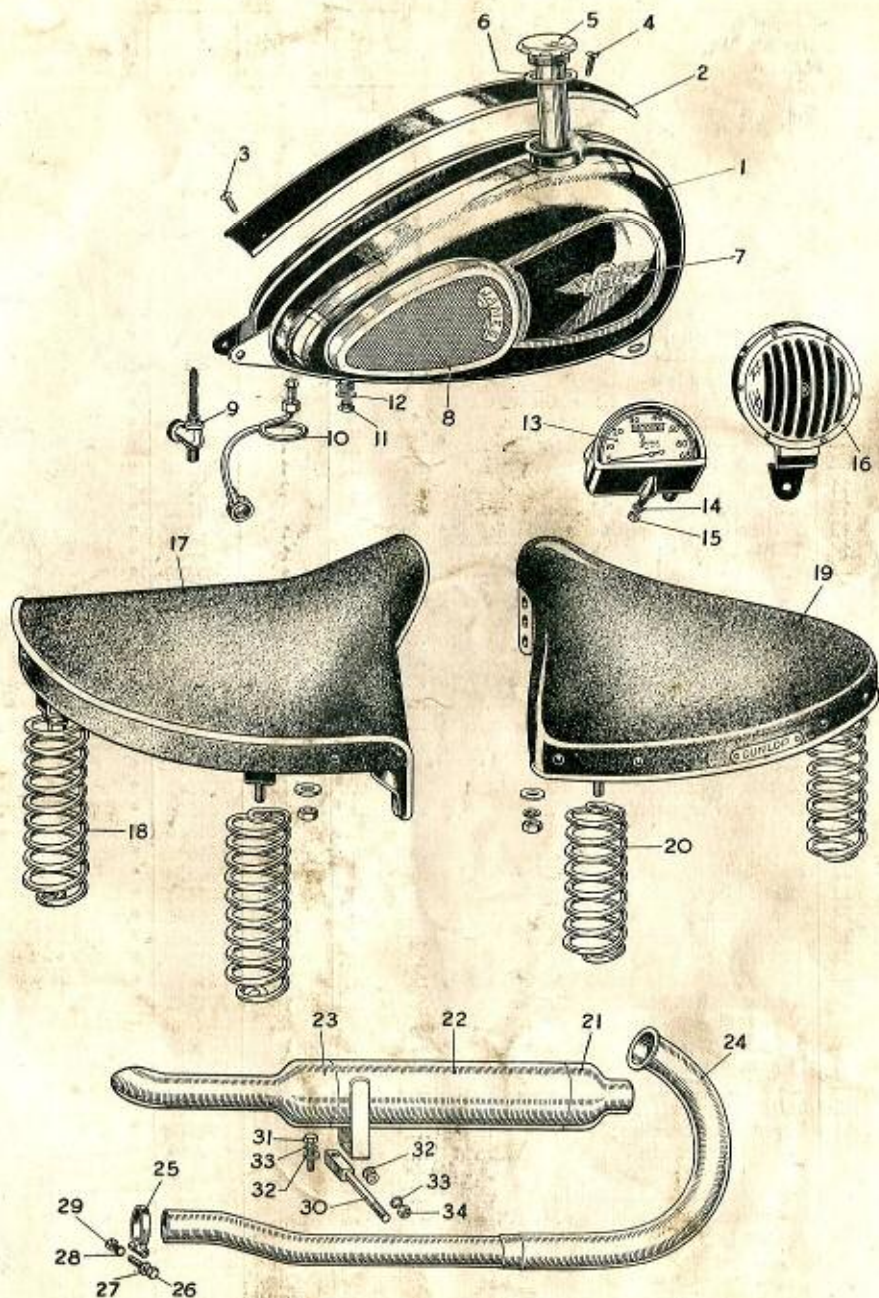

IT PAYS TO FIT GENUINE "JAMES" COMPONENTS

**LIGHTING EQUIPMENT
HANDLEBAR — CONTROLS — TOOLS**

Ill. No.	Description of Part	Qty.	Part No.	Price Each £ s. d.
A.C./D.C. RECTIFIER LIGHTING SET				
—	Headlamp complete, with underslung pilot ...	1	701563	*
—	" " without underslung pilot ...	1	701562	*
1	Chrome rim assembly ...	1	701564	*
2	Rim fixing wire ...	6	701565	*
3	Light unit ...	1	701566	*
4	Bulb holder, underslung pilot ...	1	701574	*
5	Main bulb (6 volt 24/24 watt.) ...	1	701642	*
6	Pilot bulb (6 volt 3 watt.) ...	1	—	*
7	Ammeter ...	1	701570	*
—	Ammeter rubber ring ...	1	701517	*
8	Screw — panel fixing ...	4	701571	*
9	Rubber seal — panel ...	1	701572	*
10	Switch complete ...	1	701573	*
—	" handle ...	1	701599	*
—	" " screw ...	1	701560	*
—	Spring — switchbox fixing ...	1	701519	*
—	Rubber ring — switchbox ...	1	701520	*
11	Lamp fixing screw ...	2	701531	*
12	" " washer ...	2	701532	*
13	Wiring harness (state model when ordering) ...	1	—	*
14	Tail lamp type 529 ...	1	—	*
—	" " bulb (6 volt 3 watt. M.B.C.) ...	1	701539	*
			see	
			701636	*
15	" " rubber grommet ...	—	703014	*
—	" " stop light type 525 ...	1	—	*
—	" " bulb (6 volt. 18/3 watt.) ...	1	701638	*
16	Rectifier ...	1	701510	*
17	Dipswitch and horn button ...	1	000586	*
18	Lucas 6 volt battery, uncharged ...	1	000457	*
A.C. DIRECT LIGHTING SET TYPE "M"				
—	Headlamp complete ...	1	701562	*
19	Chrome rim assembly ...	1	701564	*
20	Light unit ...	1	701566	*
21	Bulb holder (main) ...	1	701545	*
22	Main bulb (6 volt 30/30 watt. S.B.C.) ...	1	701654	*
23	Pilot bulb (3½ volt 15 amp. M.E.S.) ...	1	701631	*
24	Cable harness ...	1	701581	*
25	Switch complete ...	1	701548	*
26	Tail lamp type 480 ...	1	701561	*
—	" " bulb (6 volt 3 watt. M.B.C.) ...	1	701636	*
27	Dipper switch No. 99 ...	1	701549	*
28	Tubular dry battery carrier complete ...	1	000430	6 6
29	¾" handlebar, 25½" wide ...	1	000267	12 6
—	" " 27" ...	1	001302	15 0
30	Solid control lever ...	2	000287	2 9
31	Lever pivot bracket ...	2	000288	1 7
32	" " bracket cap ...	2	000289	6
33	" " pivot pin ½" x 26 T.P.I. ...	2	900135	1
34	Hexagon nut ½" x 26 T.P.I. ...	2	900023	1
35	Round head screw ⅝" x 32 T.P.I. ...	4	900082	3
36	Flatted nut ...	4	000390	3
37	Handlebar clip base ...	2	001700	3 6
38	" " cap ...	2	001699	3 6
—	" " flat top or bottom ...	4	002015	3 6

* Manufacturers current prices

LIGHTING EQUIPMENT—HANDLEBAR—TOOLS

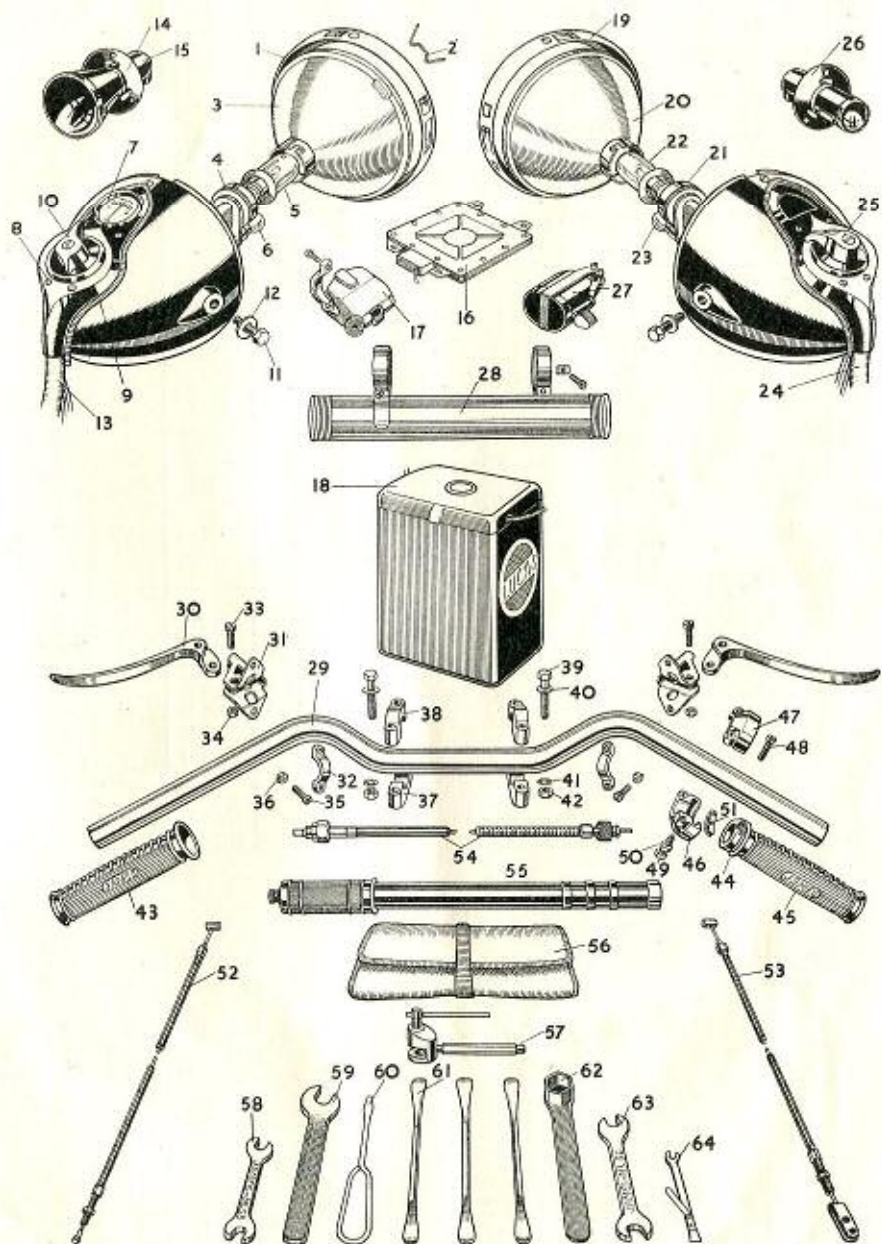

IT PAYS TO FIT GENUINE "JAMES" COMPONENTS

JAMES

SPARES STOCKISTS

For the convenience of owners, Spares Stockists are appointed for most districts. To save delay and the delivery surcharge, customers are strongly advised to obtain their requirements from their nearest Spares Stockists.

When corresponding regarding Service or Spares ALWAYS QUOTE the complete engine and frame numbers of your machine. This enables us to identify the machine without difficulty.

The James Cycle Co. Ltd.
Birmingham

ENGINE AND CLUTCH — VILLIERS 197 c.c. Mk. 8E and 7E COMP. UNITS — MODELS J7-J8-J9

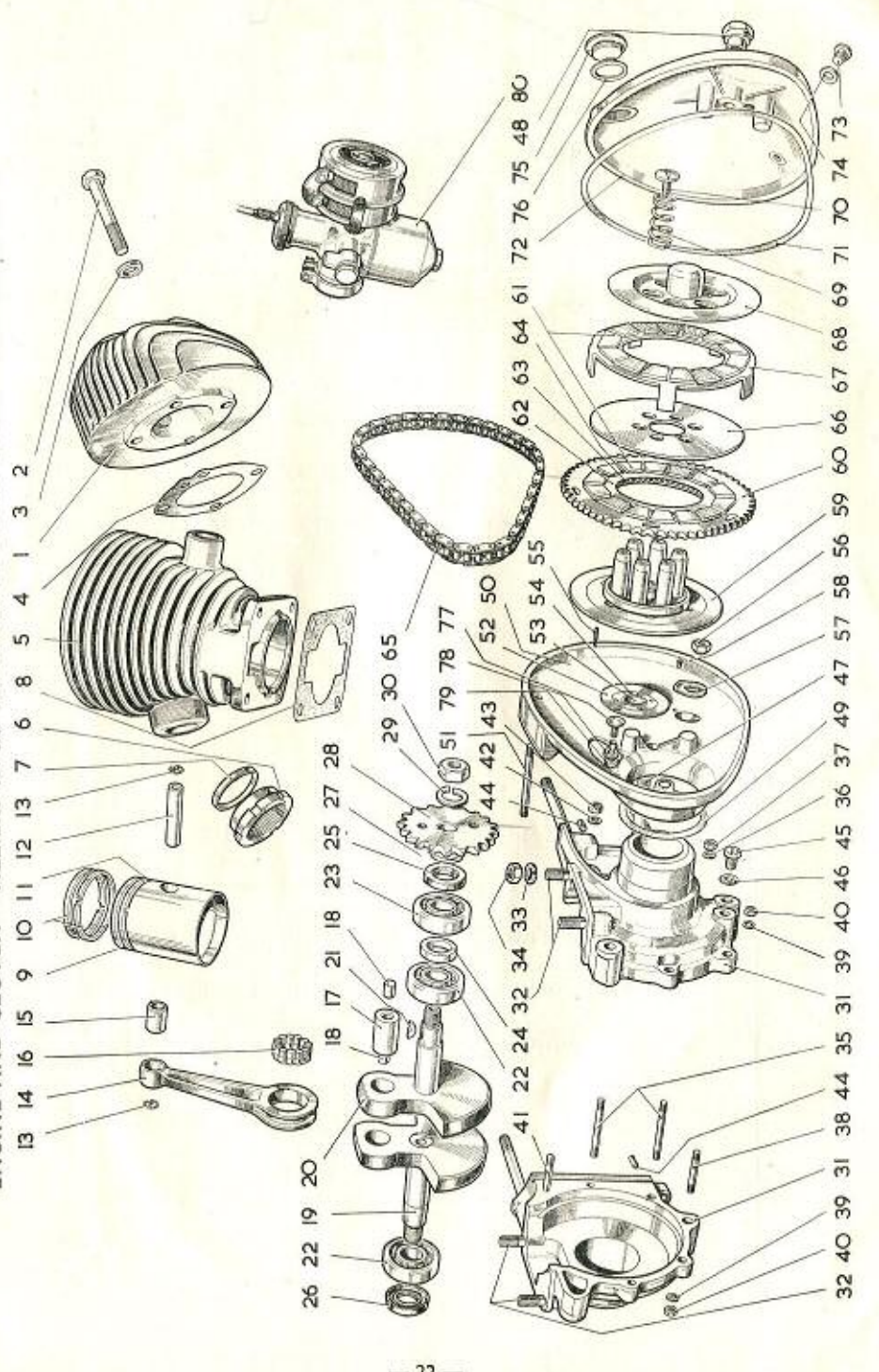

VILLIERS 197 cc. Mk. 8E and 7E Comp. Engines. MODELS J7 - J8 - J9

(See illustration page 22)

III. No.	Description of Part	Qty.	Part No.	Price Each £ s. d.
42	Washer	1	900008	1
43	Nut	1	700200	2
44	Dowel in crankcase locating gear-box	2	—	3
45	Crankcase drain plug	1	700257	4
46	Washer	1	700283	2
47	Stud for chaincase	1	700239	6
48	Nut	1	704044	9
49	Gasket	1	704045	3
50	Chaincase, inner, with gland plate	1	704046	1 6 0
51	Stud in chaincase for gearbox	1	700199	3
52	Gland plate	1	700175	8
53	Felt washer	1	700174	4
54	Rivets for gland plate	4	700287	set 3
55	Dowel for outer chaincase	1	700294	2
56	Cone nut for inner chaincase	1	700202	3
57	Lockwasher	1	700201	6
58	Screw	1	700204	2
59	Clutch centre assembly	1	700221	16 0
60	Clutch sprocket assembly, comprising items 61-65 inclusive	1	700222	18 0
61	Cork for clutch sprocket and corked plate	30	700226	1
62	Ball retaining plate	2	700223	1 0
63	Ball	50	700225	set 1 0
64	Rivet	15	700224	set 1 0
65	Primary chain	1	700229	(66 pitches)*
66	Centre plate	1	700227	6 0
67	Corked plate	1	700228	6 0
68	Front plate assembly	1	—	8 0
69	Spring	6	700258	5
70	Screw	6	700259	5
71	Gasket	1	700173	1 0
72	Chaincase — outer	1	704047	15 0
73	" oil level screw	1	704060	4
74	Washer	1	700283	2
75	Oil filler plug	1	704048	1 6
76	Washer	1	704049	3
77	Breather valve for chaincase	1	704170	6
78	Spring washer	1	900027	2
79	Nut	1	—	2
80	Carburettor complete with control and air filter (see separate drawings on pages 30 and 31 for components)	1	702215	3 15 0
	Inlet manifold, bent, Mk. 8E and 7E	1	700394	8 3
	Manifold stud	2	700367	3
	Nut for stud	2	700200	2
	$\frac{1}{8}$ " spring washer	2	700091A	2
	Manifold joint washer	1	700355	5
	Finned exhaust pipe nut	1	704169	3 3

NOTE : The 197 cc. engine fitted to model J9 with 4-speed gearbox differs slightly from its 3-speed counterpart. A list of these components is given on page 38.

IMPORTANT

PLEASE NOTE THAT ALL PRICES OF SPARES FOR VILLIERS ENGINE, MAGNETO, CARBURETTER, GEAR-BOX (EXCLUDING 4 SPEED GEAR-BOX) AND LIGHTING EQUIPMENT IN THIS LIST ARE SUBJECT TO 30% INCREASE UNTIL FURTHER NOTICE.

The James Cycle Co. Ltd.
December, 1953

Note: Due to varying costs of materials, we reserve the right to alter any price in this list without notice.

ENGINE AND CLUTCH — VILLIERS 122 cc Mk. 10D and 13D UNITS — MODEL J6. — see page 27

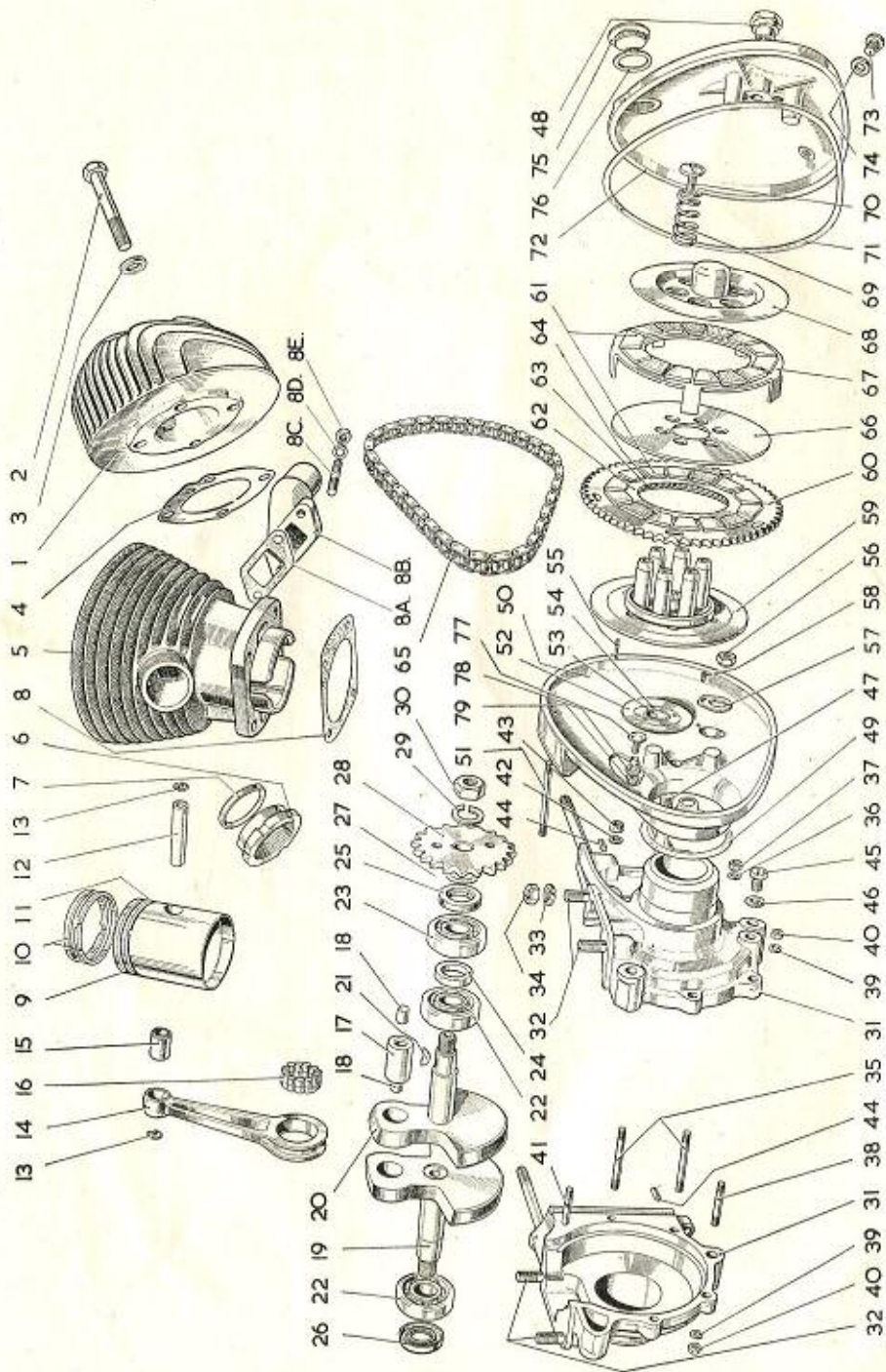

(See illustration page 26)

Ill. No.	Description of Part	Qty.	Part No.	Price £ s. d.
1	Cylinder head (no decompressor)	1	700165	1 5 0
2	" " bolt	4	700166	9
3	Washer	4	700167	2
4	Gasket for cylinder head	1	700159	4
5	Cylinder	1	700160	3 3 0
6	Nut for exhaust pipe	1	700064	1 3
7	Washer	1	700065	3
8	Gasket for cylinder base	1	700163	7
9	Piston, standard	1	700178	1 0 0
—	" .015" oversize	1	700179	1 0 0
—	" .030" oversize	1	700180	1 0 0
10	" ring, standard	2	700181	1 9
—	" " .015" oversize	2	700633	1 9
—	" " .030" oversize	2	700634	1 9
11	Expander ring	1	700182	1 0
12	Gudgeon pin	1	700217	2 3
13	Circlip	2	700289	4
14	Connecting rod, bushed, .001" oversize	1	704028	18 0
15	Small end bush	1	700216	2 6
16	Rollers for crankpin, steel	12	700645	Set 3 0
—	" " bronze	6	700646	Set 1 3
17	Crankpin, .001" oversize	1	704029	6 0
18	" plug	2	700186	3
19	Crankshaft, right-hand	1	704030	1 0 0
20	" left-hand	1	704031	1 0 0
21	Key for engine sprocket	1	700370	3
22	Ball bearing	2	700213	*
23	" "	1	700213	*
24	Distance piece for bearings	1	704033	1 0
25	Oil seal, crankshaft drive end	1	704040	3 3
26	" " magneto end	1	700214	2 0
27	Shim for engine sprocket	as reqd.	700220	3
28	Engine sprocket	1	704034	5 0
29	Spring washer	1	700671	2
30	Nut	1	700670	6
31	Crankcase, right- and left-hand halves, less fittings	{ 1 1	{ 704035 704035	} 3 0 0
32	Stud in crankcase for cylinder	4	700243	3
33	Spring washer	4	70091/A	2
34	Nut	4	700091	2
35	Stud (fitted) securing crankcase halves	2	700374	4
36	Washer	2	700611	1
37	Nut	2	700680	2
38	Stud (fitted) securing crankcase halves, short	2	700606	3
39	Washer	2	700678	1
40	Nut	2	700680	2
41	Stud securing crankcase halves	1	704043	3
42	Washer	1	700678	1
43	Nut	1	700200	2
44	Dowel in crankcase locating gearbox	2	700030	3
45	Crankcase drain plug	1	700257	4
46	Washer	1	700651	2
47	Stud for chaincase	1	700239	6
48	Nut	1	704044	9
49	Gasket	1	704045	3
50	Chaincase, inner, with gland plate	1	704046	1 6 0
51	Stud in chaincase for gearbox	1	700199	3
52	Gland plate	1	700175	8

ENGINE AND CLUTCH — continued

III. No.	Description of Part	Qty.	Part No.	Price £ s. d.
53	Felt washer	1	700288	4
54	Rivets for gland plate	4	700287	Set 3
55	Dowel for outer chaincase	1	700294	2
56	Cone nut for inner chaincase	1	700202	3
57	Lockwasher	1	700201	6
58	Screw	1	700204	2
59	Clutch centre assembly	1	700221	16 0
60	Clutch sprocket assembly, comprising items 61-65 inclusive	1	700222	18 0
61	Cork for clutch sprocket and corked plate	30	700226	1
62	Ball retaining plate	2	700223	1 0
63	Ball	50	000162	Set 1 0
64	Rivet	15	700224	Set 1 0
65	Primary chain	1	700229	(64 pitches) *
66	Centre plate	1	700227	6 0
67	Corked plate	1	700228	6 0
68	Front plate assembly	1	700230	8 0
69	Spring	6	700258	5
70	Screw	6	700259	5
71	Gasket	1	700173	1 0
72	Chaincase, outer	1	704047	15 0
73	" " oil level screw	1	704068	4
74	Washer	1	700283	2
75	Oil filler plug	1	704048	1 6
76	Washer	1	704049	3
77	Breather valve for chaincase	1	700215	6
78	Spring washer	1	—	2
79	Nut	1	900027	2
8B	Inlet manifold, bent	1	700168	8 3
8A	Joint washer	1	700169	5
8C	Stud for manifold	2	700245	3
8E	Nut for stud	2	700199	2
8D	Washer for stud	2	—	2

* Manufacturers current price

FLYWHEEL MAGNETO

III. No.	Description of Part	Qty.	Part No.	Price £ s. d.
1	Flywheel cover	1	703065	6 6
2	" " assembly	1	703069	4 18 0
3	Screw, pole shoe	12	703073	3
4	Top plate, pole shoe, iron	5	703022	3
4	" " " " brass	1	703071	3
5	Magnet	6	703070	9 0
6	Rocker arm spring	1	703033	3
7	" "	1	703059	4 6
8	Low tension lead	1	703058	6
9	Lighting coils with cheeks	1 pr.	703163	1 4 0
10	H.T. coil end, left-hand	1	703018	2 6
10	" " " right-hand	1	703019	2 6
11	" " " "	1	703015	1 0 0
12	" terminal pad	1	703013	2
13	H.T. terminal spring	1	703012	2

FLYWHEEL MAGNETO — continued

Ill. No.	Description of Part	Qty.	Part No.	Price £ s. d.
14	" " felt washer	1	703011	3
15	" " cover	1	703010	1 0
—	" " " cover	1	703086	6
16	Screw, L.T. lead	1	703026	2
17	Brass washer	1	703027	1
18	Lockscrew, point bracket	1	703025	4
19	Brass washer	1	703024	2
20	Insulating washer	1	703023	2
21	Point bracket	1	703022	2 3
22	Insulating pad	1	703007	3
23	Condenser box	1	703005	5 0
—	" " assembly	1	703050	18 6
24	Condenser	1	703006	4 6
—	" " box fixing stud	2	703029	3
—	Washer for stud	2	703054	2
—	Nut for stud	2	703055	1
25	Flywheel cover clip	3	703066	4
—	Cotter for clip	3	703067	1
26	Cover joint ring	1	703157	6
—	" " badge washer	1	703158	2½
—	Armature plate assembly with lighting and ignition coils	1	703159	4 12 0
—	Armature vent tube	1	703160	6
—	Coil and screw, $\frac{3}{16}$ " dia.	2	703064	3
—	" " " $\frac{3}{16}$ " dia.	2	703074	3
—	H.T. lead complete	1	703061	4 6

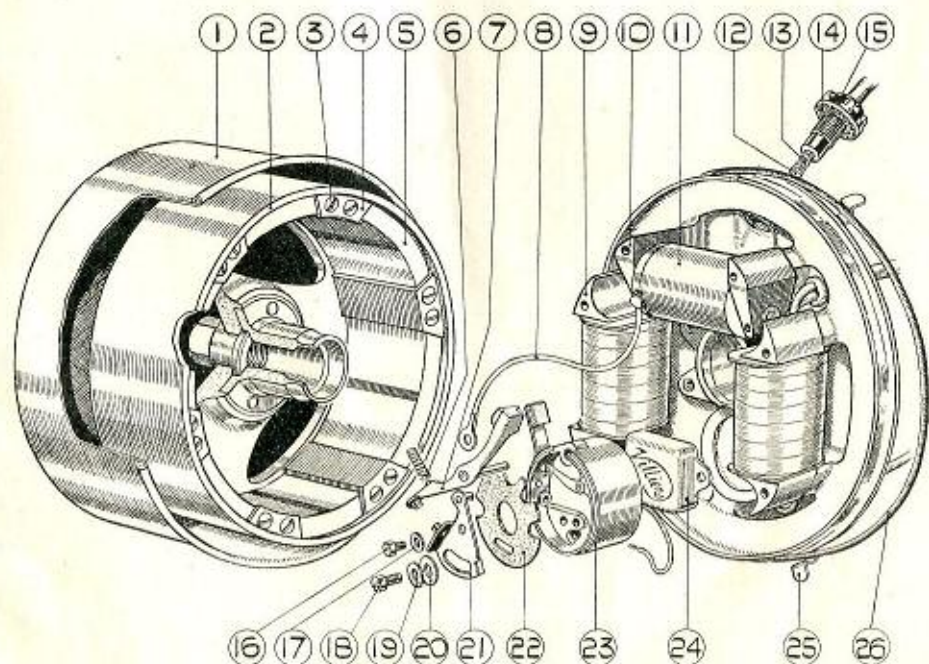

VILLIERS CARBURETTOR. TYPE S.24
 FITTED TO JAMES MODELS J7-J8-J9

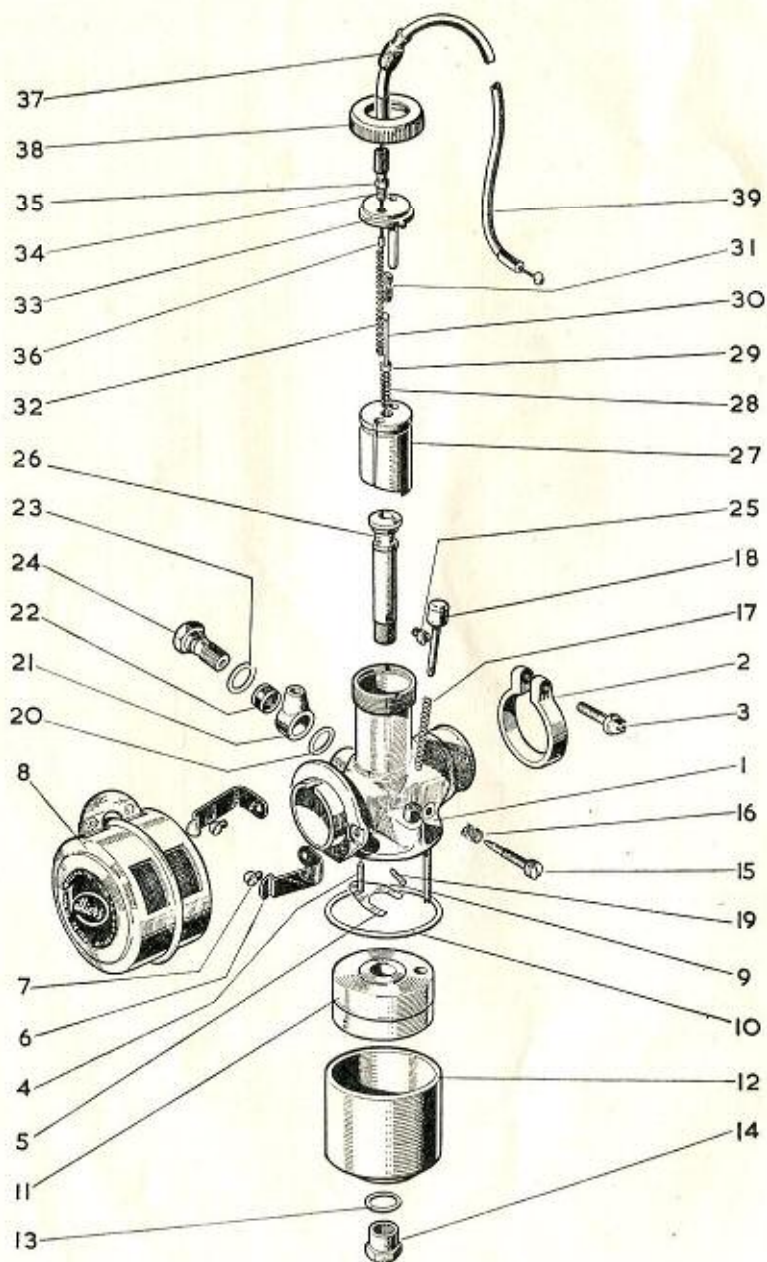

VILLIERS CARBURETTER TYPE S.24—MODELS J7-J8-J9

Ill. No.	Description of Part	Qty.	Part No.	Price Each £ s. d.
1	Body with fuel bush	1	702216	1 2 6
2	Body clip	1	702098	2 0
3	" " screw	1	702217	6
4	Fuel needle	1	702021	9
5	" " lever	1	702079	9
6	Air filter clip	2	702218	3
7	Screw for clip	2	702219	2
8	Air filter	1	702220	11 0
9	Pilot jet	1	702221	1 0
10	Cup joint washer	1	702010	6
11	Float	1	702222	6 6
12	" cup	1	702223	5 0
13	Bottom nut washer	1	702030	2
14	Bottom nut	1	702230	1 0
15	Pilot jet needle	1	702224	9
16	Spring for needle	1	702225	2
17	Tickler spring	1	702026	3
18	Tickler	1	702002	5
19	" split pin	1	702027	1
20	Washer, small hole	1	702018	3
21	Banjo union	1	702020	1 9
22	Filter gauze	1	702231	6
23	Washer, large hole	1	702017	3
24	Banjo bolt	1	702016	1 0
25	Main jet, centrepiece	1	702226	6
26	Centrepiece	1	702227	4 0
27	Throttle	1	702228	5 0
28	Needle spring	1	702229	3
29	" collar	1	702230	2
30	Taper needle No. 3 $\frac{1}{2}$	1	702231	9
31	Needle adjuster	1	702232	6
32	Throttle spring	1	702064	6
33	Top disc with peg	1	702233	2 6
34	Cable adjuster	1	702032	7
35	Adjuster locknut	1	702033	2
36	Cable nipple	1	702091	2
37	" cover	1	702234	3
38	Top ring	1	702057	1 3
39	Throttle cable complete	1		

FOR THE CONVENIENCE OF OWNERS

SPARES STOCKISTS

are appointed for most districts. To save delay, customers are recommended to apply always to their nearest Spares Stockist

VILLIERS CARBURETTER. TYPE 3/4
 FITTED TO MODEL J6 122 c.c. CADET DE LUXE

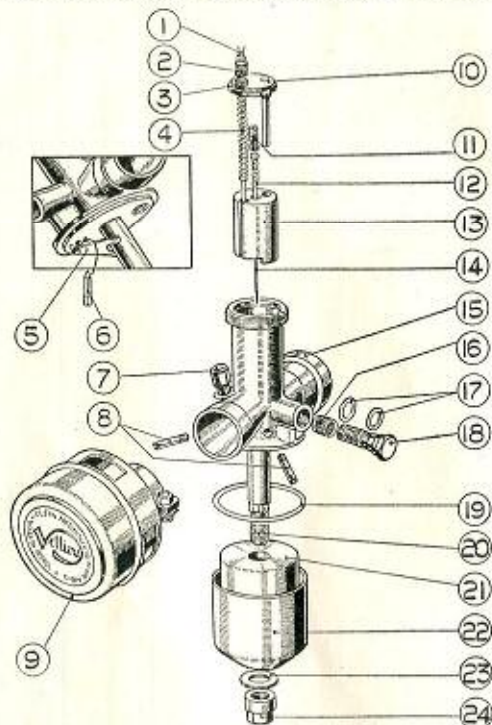

Ill. No.	Description of Part	Qty.	Part No.	Price £ s. d.
—	Carburetter complete with control and air cleaner	—	702055	2 19 6
—	Body with fuel bush, needle lever	1	702056	13 3
—	Top ring	1	702057	1 3
1	Control cable assembly	1	001648	5 0
2	" " adjuster	1	702088	7
3	" " locknut	1	702089	2
—	" " sleeve	1	702090	4
—	Cable nipple, throttle end	1	702091	2
—	" " control end	1	702092	2
4	Throttle return spring	1	702064	6
5	Fuel needle lever	1	702079	9
6	Fuel needle	1	702021	9
7	Tickler	1	702074	5
—	" spring	1	702075	3
—	" split pin	1	702076	1
8	Compensating tube	2	702077	6
9	Air filter with strangler	1	702070	10 0
—	" " clip	1	702071	1 6
—	" " screw	1	702072	3
—	" " nut	1	702025	2
10	Top disc with guide peg	1	702058	9
11	Needle adjusting screw	1	702013	6
12	Taper needle spring	1	702018	3
13	Throttle slide	1	702089	4 3

CARBURETTER — continued

III. No.	Description of Part	Qty.	Part No.	Price £ s. d.
14	Taper needle No. 3	1	702060	9
15	Body clip	1	702062	2 0
—	" and control clip screw	3	702010	6
16	Banjo filter gauze	1	702019	6
17	Fibre washer, large hole	1	702017	3
17	" " small hole	1	702069	3
—	Banjo union	1	702020	1 9
18	" " bolt	1	702016	1 0
19	Fibre washer float cup	1	702001	6
20	Centrepiece and jet	1	702084	5 0
—	" fibre washer	1	702030	2
21	Float	1	702003	3 6
22	Float cup	1	702004	3 3
23	Fibre washer, bottom nut	1	702006	2
24	Bottom nut	1	702005	1 0

THREE-SPEED GEARBOX — MODELS J6-J7-J8 and some J9

(Illustration on page 34)

III. No.	Description of Part	Qty.	Part No.	Price £ s. d.
1	Gearbox, bushed	1	704050	2 0 0
2	Ball bearing	1	000162	*
3	Oil seal	1	704003	1 9
4	Sprocket distance piece	1	704015	1 3
5	" standard, 15 teeth	1	704052	7 0
5	" alternative, 17 teeth	1	704053	8 6
6	" locknut	1	700295	1 2
7	Screw for locknut	1	700204	2
8	Spring washer	1	700203	2
9	Sealing disc	1	700710	6
10	Oil filler plug	1	700255	1 3
11	Washer for plug	1	700281	2
12	Oil drain plug	1	700257	1 3
13	Washer for plug	1	700282	2
14	Layshaft bush	1	700234	1 9
15	Stud for end plate	3	700247	3
16	Dowel	2	700188	3
17	Selector pivot pin	1	704054	1 9
18	" quadrant	1	704055	1 0 0
19	" plunger	1	704056	1 6
20	Plunger spring, short	1	704057	3
21	" " long	1	704058	4
22	Oil level plug	1	700257	4
23	Washer for plug	1	700283	2
24	Bearing sealing washer	1	700298	4
25	Mainshaft	1	700301	17 0
26	High gear pinion	1	704059	19 0
27	Pressure washer	1	700332	9
28	Mainshaft sliding pinion	1	700302	9 6
29	" fixed pinion	1	700303	6 9
30	Layshaft	1	700307	14 0
31	" fixed pinion	1	700304	6 9
32	" sliding pinion	1	700306	9 6
33	Sliding gear operator	1	700329	2 0
34	Ratchet pinion	1	700308	13 9
35	Push rod, headed	1	700250	9

THE VILLIERS THREE-SPEED GEARBOX

(See pages 33 and 35)

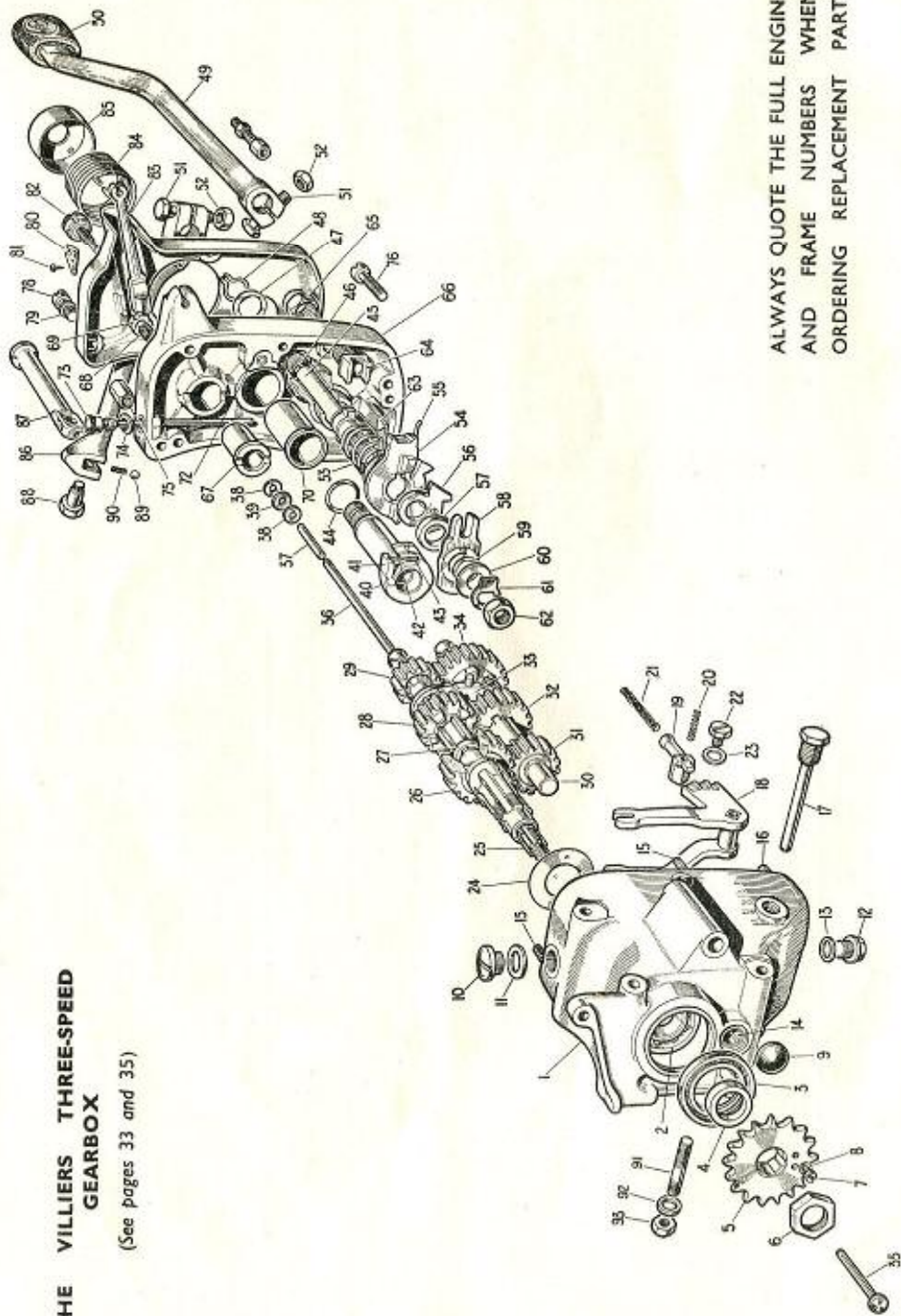

ALWAYS QUOTE THE FULL ENGINE
AND FRAME NUMBERS WHEN
ORDERING REPLACEMENT PARTS

THREE-SPEED GEARBOX — continued

Ill. No.	Description of Part	Qty.	Part No.	Price £ s. d.
36	Push rod, long	1	700262	8
37	" " short	1	700263	4
38	Steel washer	2	700265	2
39	Felt washer	1	700388	3
40	Kickstart shaft, bushed	1	700312	16 0
41	" " pawl	1	700309	9
42	" " plunger	1	700310	4
43	Plunger spring	1	700738	2
44	Sealing ring	1	704060	6
45	Operating spindle	1	700335	12 0
46	Sealing ring	1	703156	6
47	Pressure washer	1	700220	3
48	Spindle circlip	1	700346	3
49	Foot change lever	1	700349	9 6
50	Rubber for lever	1	700320	1 6
51	Bolt for foot lever	2	700318	7
52	Nut for bolt	2	700319	3
53	Ratchet spring	1	700344	6
54	Operating pawl	1	704062	7 6
55	" " spring	1	700343	1 0
56	" " spindle plate	1	704063	2 6
57	" " distance piece	1	700337	4 4
58	" " lever	1	700347	4 6
59	Operating spindle shim	as reqd.	700338	2
60	" " washer	1	700339	3
61	" " lockwasher	1	700340	2
62	" " nut	1	700341	3
63	Stop pin	1	700348	1 0
64	Plunger box	1	704064	2 6
65	" " nut	1	704064	1 0
66	End plate, bushed	1	704066	1 10 0
67	Mainshaft bush	1	700233	4 0
68	Adjuster bush	1	700330	6
69	" " locknut	1	700331	3
70	Bush kickstart shaft	1	704067	2 6
71	" " operating spindle	1	700232	3 0
72	Kickstart stop piece	1	700333	6
—	Screw for stop piece	1	700334	4
73	Dipstick	1	700290	1 6
74	Washer for dipstick	1	700291	2
75	End plate nut	3	700286	3
76	" " screw	3	700251	4
77	Dust cover	1	700210	10 0
78	" " screw	3	700292	3
79	Washer for screw	3	700279	1
80	Adjuster locking plate	1	700284	3
81	Fixing screw	2	700285	1
82	Clutch adjusting screw	1	700261	1 6
83	" " lever	1	700260	2 6
84	Return spring	1	—	10
85	Cap for spring	1	700325	1 3
86	Kickstart lever	1	700313	10 0
87	" " pedal	1	700314	4 6
88	Pedal pivot pin	1	700315	6
89	Ball for pivot pin	1	000371	2
90	Spring for ball	1	700317	2
91	Stud	1	700948	3
92	Washer	1	700196	1
93	Nut	1	700197	2

VILLIERS 4 SPEED GEARBOX — MODEL J9

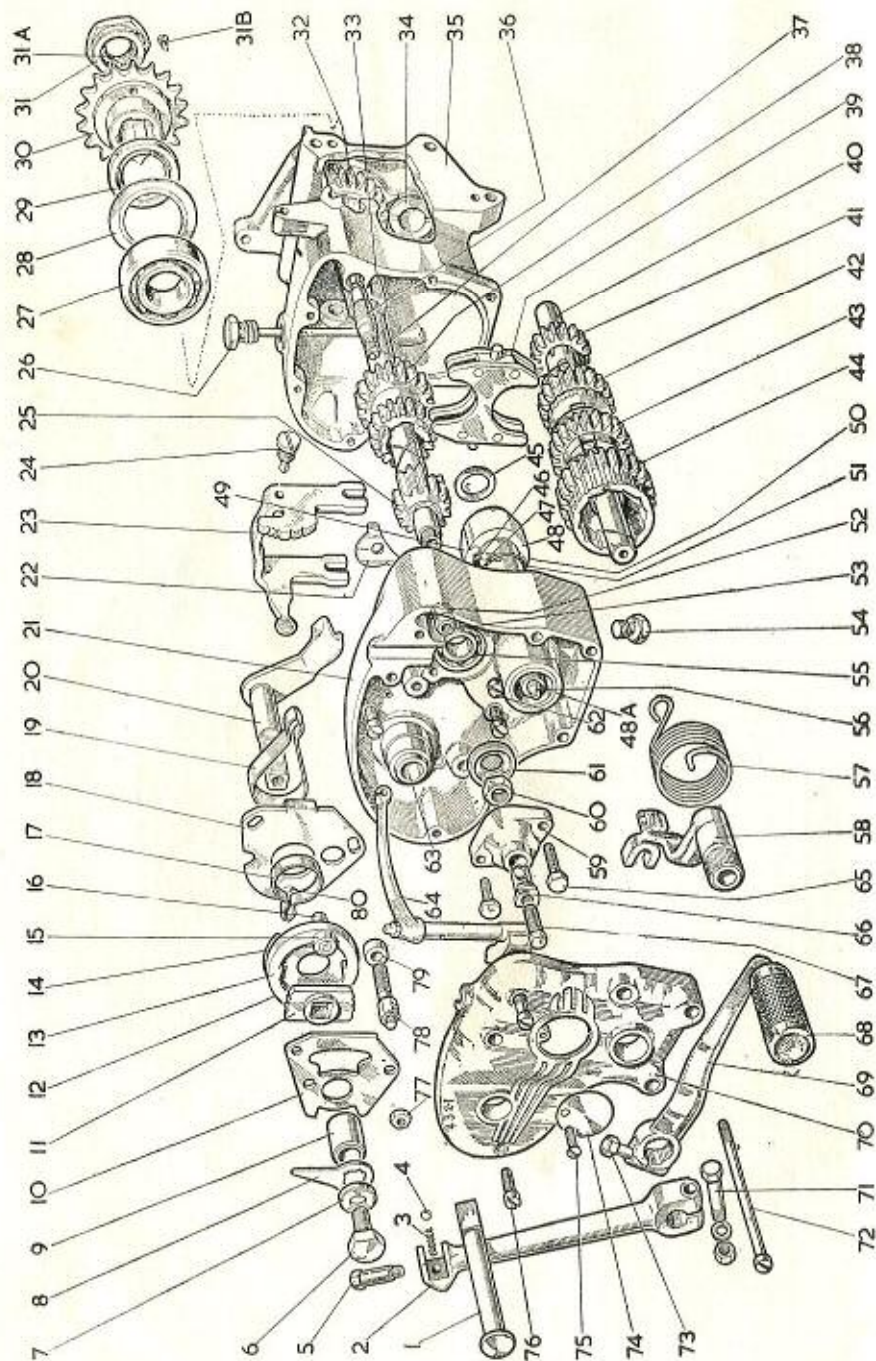

NOTE: Prices of parts for Villiers 4 speed gearbox are not subject to 30% increase.

FOUR-SPEED GEARBOX — MODEL J9

Ill. No.	Description of Part	Qty.	Part No.	Price £ s. d.
1	K.S. Crank Pedal	1	704116	2 3
2	K.S. Crank	1	704115	9 0
3/4	K.S. Crank Pedal Spring and Ball	1	704118	5
5	K.S. Crank Pedal Bolt	1	704117	9
6	Operator Shaft Securing Pin	1	704145	9
7	Dished Washer	1	704144	9
8	Gear Indicator	1	704143	9
9	Outer Bush for Operator	1	704142	3 0
10	Stop Plate and Spring Retainer	1	704140	3 0
11	Control Ratchet Female	1	704139	4 6
13	Control Ratchet Male	1	704136	6 0
14	Control Plate	1	704135	2 3
15	Bush for Control Plate Pin	2	704137	3
	Spring Stop for Control Plate	1	704134	6
16	Operating Pin for Pawl Plate	1	704138	6
17	Pawl Plate Spring	1	704133	9
18	Adjuster Plate	1	704127	3 0
19	Lever Return Spring	1	704132	1 6
20	Operator Shaft (Complete with lever)	1	704125	6 0
21	Gear Box Cover	1	704071	1 17 6
22	K.S. Stop Plate	1	704092	1 6
23	Inside Operator	1	704100	7 2
24	Inside Operator Anchor Pins	2	704101	6
25	Mainshaft High Gear Pinion 15T	1	704080	10 6
26	Dip Stick	1	704122	2 3
27	Ball Race (Large)	1	704075	16 2
28	Oil Seal Retainer	1	704074	5
29	Gear Box Oil Seal	1	704073	2 3
30	Final Drive Sprocket, 17T.	1	704149	11 3
31	Sprocket Gland Nut	1	704150	1 9
31a	Sprocket Gland Nut Felt Washer	1	704151	5
31b	Sprocket Locking Screw	1	704152	2
32	Mainshaft Low Gear Pinion 26T	1	704076	15 9
33	Mainshaft Sleeve	1	704077	1 6 3
34	Layshaft Bush (Box)	1	704084	3 0
35	Gear Box Case	1	704070	1 16 0
36	Selector Plunger	1	704120	3 5
	—Selector Plunger Box — Assembled			
37	Mainshaft	1	704078	1 13 0
38	Mainshaft Sliding Gear, 21T and 18T	1	704079	1 9 8
39	Operator Fork	1	704102	5 8
40	Layshaft	1	704086	1 2 2
41	Layshaft Low Gear Pinion, 16T	1	704085	10 6
42	Layshaft 2nd Gear Pinion, 21T	1	704087	1 2 2
43	Layshaft 3rd Gear Pinion, 24T	1	704088	1 4 0
44	Layshaft High Gear Pinion and K.S. Pinion 27T	1	704089	1 2 2
45	Layshaft Bush Pen Steel Washer	1	704090	5
	*Layshaft Bush (K.S. End)	1	704091	3 0
46	K.S. Pawl Plunger	1	704095	6
47	K.S. Pawl Plunger Spring	1	704096	5
48	K.S. Shaft	1	704097	1 1 9
48a	K.S. Shaft Bush	1	704099	5 3
49	K.S. Pawl	1	704094	3 0
51	K.S. Oil Seal Ring	1	704098	9
52/	Selector Plunger Spring	1	704121	5
53	Selector Plunger Box Washer and Nut	1		
54	Drain Plug	1	704123	9
55	Ball Race (Small)	1	704081	11 8

Note: Prices of parts for 4 speed gearbox are **NOT** subject to 30% increase.

FOUR SPEED GEARBOX — MODEL J9 — continued

Ill. No.	Description of Part	Qty.	Part No.	Price £ s. d.
56	Grease Nipple	2	704131	9
57	K.S. Return Spring	1	704114	1 6
58	Short Control Lever	1	704130	5 3
59	Bearing Cap	1	704106	5 3
60	Mainshaft Nut, Left Hand Thread	1	704083	6
61	Oil Thrower	1	704082	1 6
62	K.S. Stop Plate Pin	1	704093	3
63	Operator Bush	1	704124	3 0
64	Clutch Lever	1	704111	6 9
65	Bearing Cap Pins, 1" x $\frac{1}{8}$ " HEX.	1	704107	5
	$\frac{9}{16}$ " x $\frac{1}{4}$ " HEX.	1	704108	5
66	Clutch Lever Adjuster Sleeve and Ball	1	704109	2 3
67	Clutch Lever Adjuster Pin	1	704110	9
68	Foot Change Rubber	1	704148	1 6
69	Foot Change Lever	1	704146	6 9
70	Gear Box Cap	1	704072	15 0
71	K.S. Crank Pinch Pin, Nut	1	704119	9
72	Cover Pins, 3" x $\frac{1}{2}$ " CH.	4	704103	6
	1 $\frac{1}{16}$ " x $\frac{1}{4}$ " CH.	2	704104	6
	$\frac{3}{8}$ " x $\frac{1}{4}$ " CH.	3	704105	6
73	Clip Bolt for Lever	1	704147	3
74	Inspection Cover	1	704112	5
75	Inspection Cover Pin	1	704113	2
77	Nut for Adjuster Plate Pin	2	704141	2
78	Adjuster Plate Pin	2	704129	9
79	Bush for Adjuster Pin	2	704128	2
80	Spring Stop for Adjuster Plate	1	704126	3

*Not supplied separately.

IMPORTANT : The following engine components fitted to the 4-speed model J9 differ slightly from those listed for the Villiers 197 cc. engine and 3-speed gearbox. Owners of J9 machines should therefore refer to the following list when ordering spares.

Ill. No.	Description of Part	Qty.	Part No.	Price £ s. d.
—	Chaincase inner half	1	704156	1 6 0
—	Clutch centre assembly	1	704157	16 0
—	Push rod headed	1	700747A	9
—*	" " long $7\frac{1}{8}$ "	1	704158	8
—*	" " " $7\frac{1}{2}$ "	1	704159	8
—*	" " " $7\frac{3}{8}$ "	1	704160	8
—*	" " " 7"	1	704161	8
—	Mainshaft nut	1	704162	6
—	" washer (spring)	1	704163	2

* Alternatives — state length when ordering

NOTES

THE JAMES GUARANTEE AND CONDITIONS OF SALE.

We give the following guarantee with our motor cycles, motor cycle combinations, and sidecars, including all accessories and component parts other than tyres, saddles, chains, and lighting and electrical equipment, and other than accessories and component parts supplied to the order of the Purchaser and differing from those comprised in the standard specifications supplied with our motor cycles, motor cycle combinations and sidecars, but including accessories and parts supplied by way of exchange as hereinafter provided. This guarantee is given in place of any implied conditions or warranties or any liabilities whatsoever statutory or otherwise; no guarantee except that hereinafter contained and no conditions or warranty whatsoever statutory or otherwise is given or is to be implied, nor are we to be under any liability whatsoever except under the guarantee hereinafter contained. Any statement, description, condition, or representation contained in any catalogue advertisement, leaflet or other publication shall not be construed as enlarging, varying or overriding anything herein contained. In the case of machines (a) which have been used for "hiring out" purposes or (b) any motor cycle and/or sidecar used for any dirt track, cinder track or grass track racing or competitions (or any competition of any kind within an enclosure for which a charge is made for admission to take part in or view the competition) or (c) machines from which the trade mark, name or manufacturing number has been altered or removed or (d) any machines in which parts have been used not supplied by or approved by the motor cycle manufacturer, or (e) any machine from which the silencing system as fitted by the manufacturer has been partially or wholly removed or interfered with, no guarantee, condition or warranty of any kind statutory or otherwise is given or is to be implied nor are we to be under any liability whatsoever in respect of any such machine.

We guarantee, subject to the conditions mentioned below, that all precautions which are usual and reasonable have been taken by us to secure excellence of materials and workmanship, but this guarantee is to extend and be in force for six months only from date of purchase, or date of exchange in case of any accessory or part supplied by way of exchange as hereinafter provided, and damages for which we make ourselves responsible under this guarantee are limited to the free repair of or supply of a new part or accessory in exchange for the part of the motor cycle, motor cycle combination or sidecar or accessory which may have proved defective. We undertake, subject to the conditions mentioned below, to make good in manner aforesaid any part or accessory covered by this guarantee which has proved defective within the said period of six months. We do not undertake to replace or refix, or bear the cost of replacing or refixing any such new part or accessory in the motor cycle, motor cycle combination or sidecar. As motor cycles, motor cycle combinations and sidecars are easily liable to derangement by neglect or misuse, this guarantee does not apply to defects caused by wear and tear, misuse or neglect.

The term "misuse" shall include, amongst others, the following acts:

1. The attaching of a sidecar to a motor cycle in such a manner as to cause damage or calculated to render the latter unsafe when ridden.
2. The use of a motor cycle or of a motor cycle and sidecar combined, when carrying more persons or a greater weight than that for which the machine was designed by the manufacturers.
3. The attaching of a sidecar to a motor cycle by any form of attachment not provided, supplied, or approved by the manufacturers, or to a motor cycle which is not designed for such use.

We do not guarantee tyres, saddles, chains or lighting and electrical equipment or any accessories or component parts supplied to the order of the Purchaser differing from those comprised in the standard specifications supplied with our motor cycles, motor cycle combinations or sidecars. As regards all such tyres, saddles, chains, lighting and electrical equipment, accessories and component parts, no guarantee condition or warranty of any kind statutory or otherwise is given or is to be implied, and we are to be under no liability whatsoever in respect thereof.

CONDITIONS OF GUARANTEE.

If a defective part or accessory should be found in our motor cycles, motor cycle combinations or sidecars, or in any part or accessory supplied by way of exchange as before provided, it must be sent to us CARRIAGE PAID, and accompanied by an intimation from the owner that he desires to have it repaired or exchanged free of charge under our guarantee and he must also furnish us at the same time with the number of the machine, the date of the purchase or the date when the alleged defective part or accessory was exchanged as the case may be.

Failing compliance with the above, such articles will lie here at THE RISK OF THE OWNER, and this guarantee and any implied guarantee, warranty or condition shall not be enforceable.

REPAIRS

Any motor cycle, motor cycle combination or sidecar sent to us to be plated, enamelled or repaired will be repaired upon the following conditions, i.e., we guarantee that all precautions which are usual and reasonable have been taken by us to secure excellence of materials and workmanship, such guarantee to extend and be in force for three months only from time such work shall have been executed, and this guarantee is in lieu and in exclusion of all conditions and warranties statutory or otherwise and all liabilities whatsoever and the damages recoverable are limited to the cost of any further work which may be necessary to amend and make good the work found to be defective.

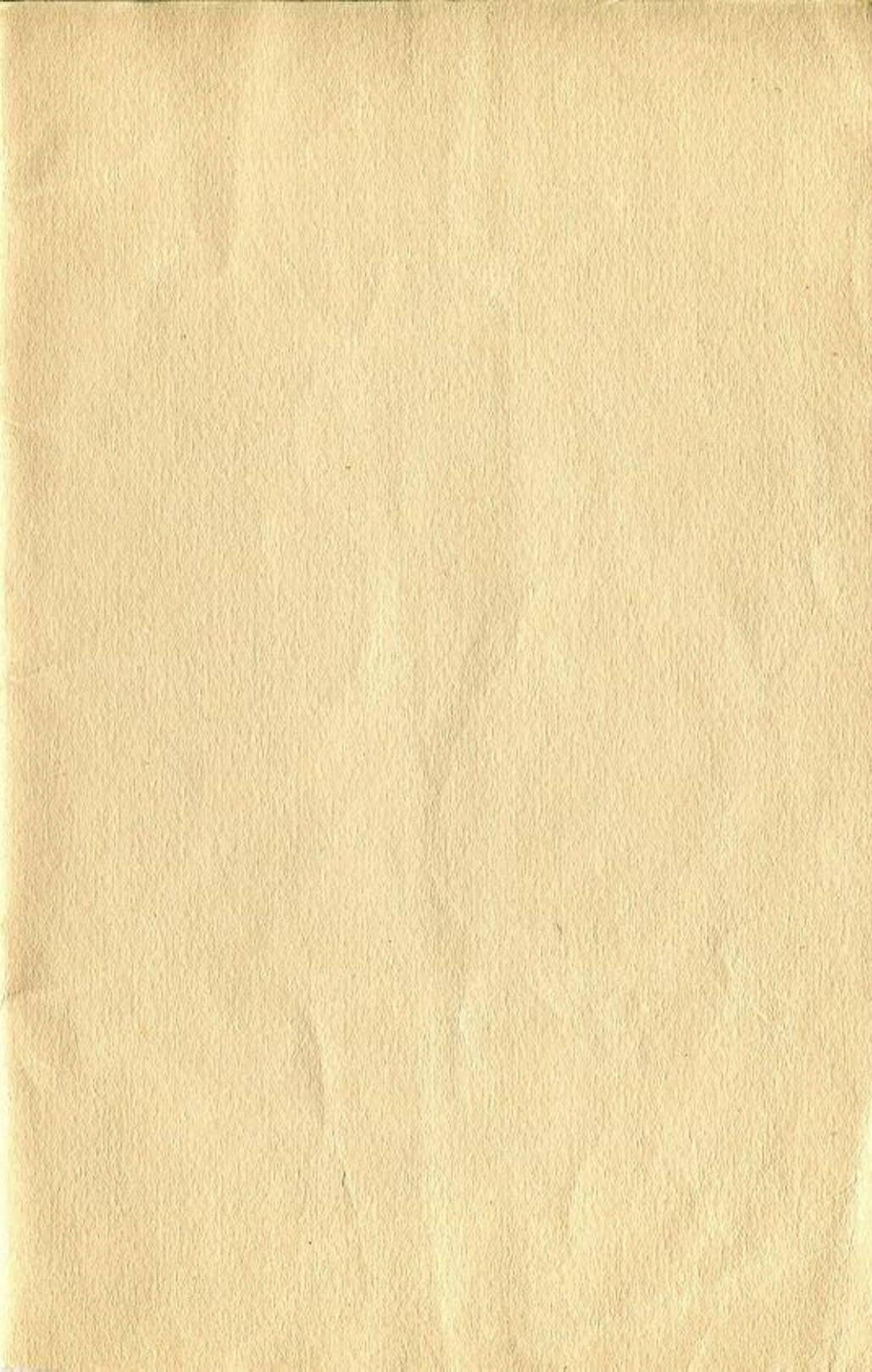

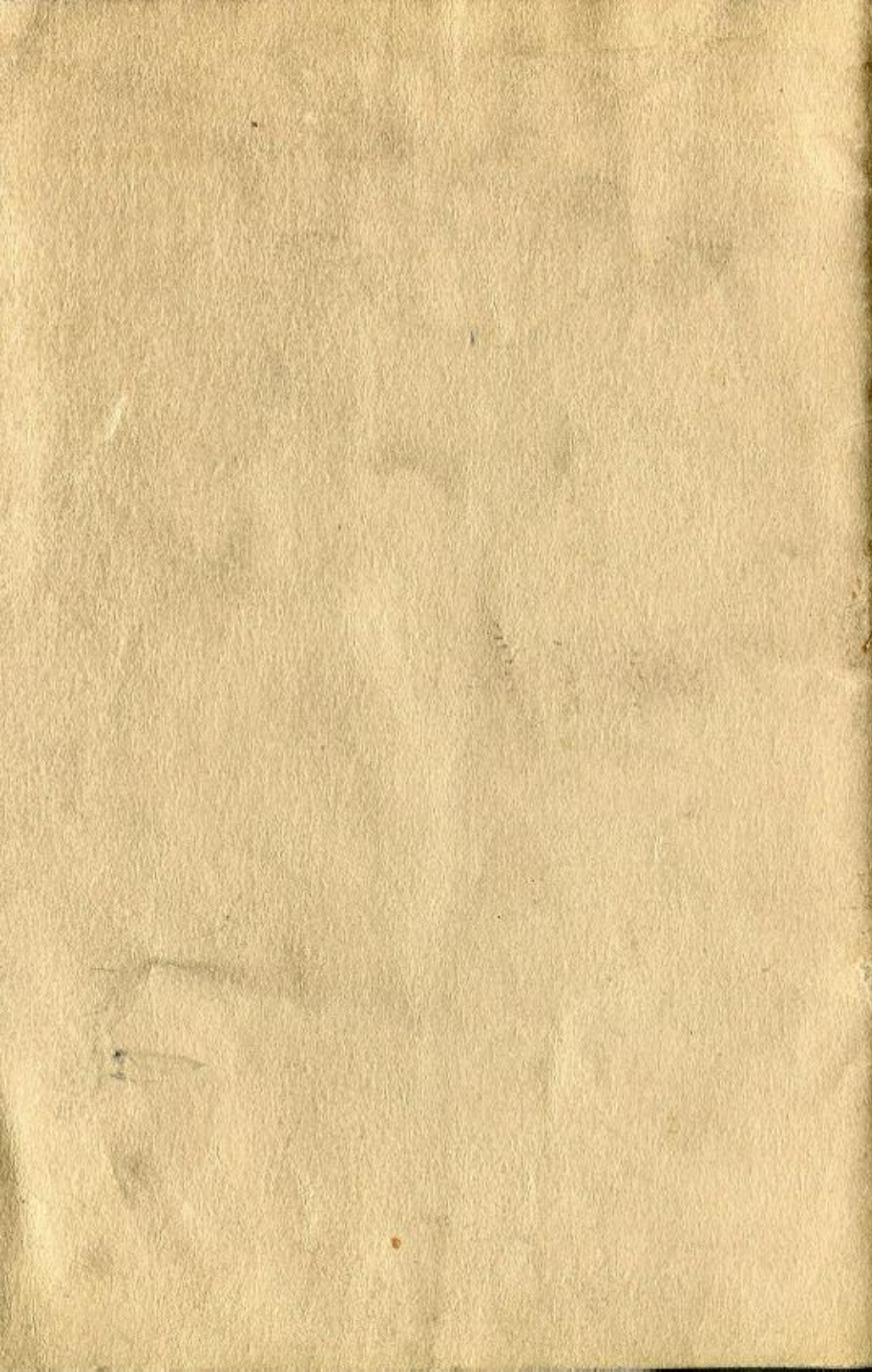

IceniCAM Information Service

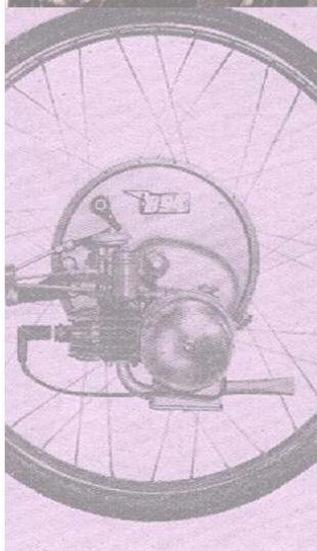
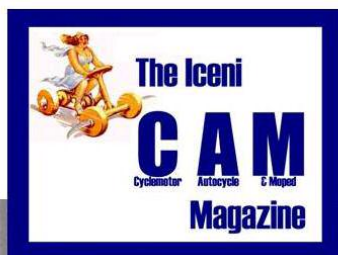

www.icenicam.org.uk