

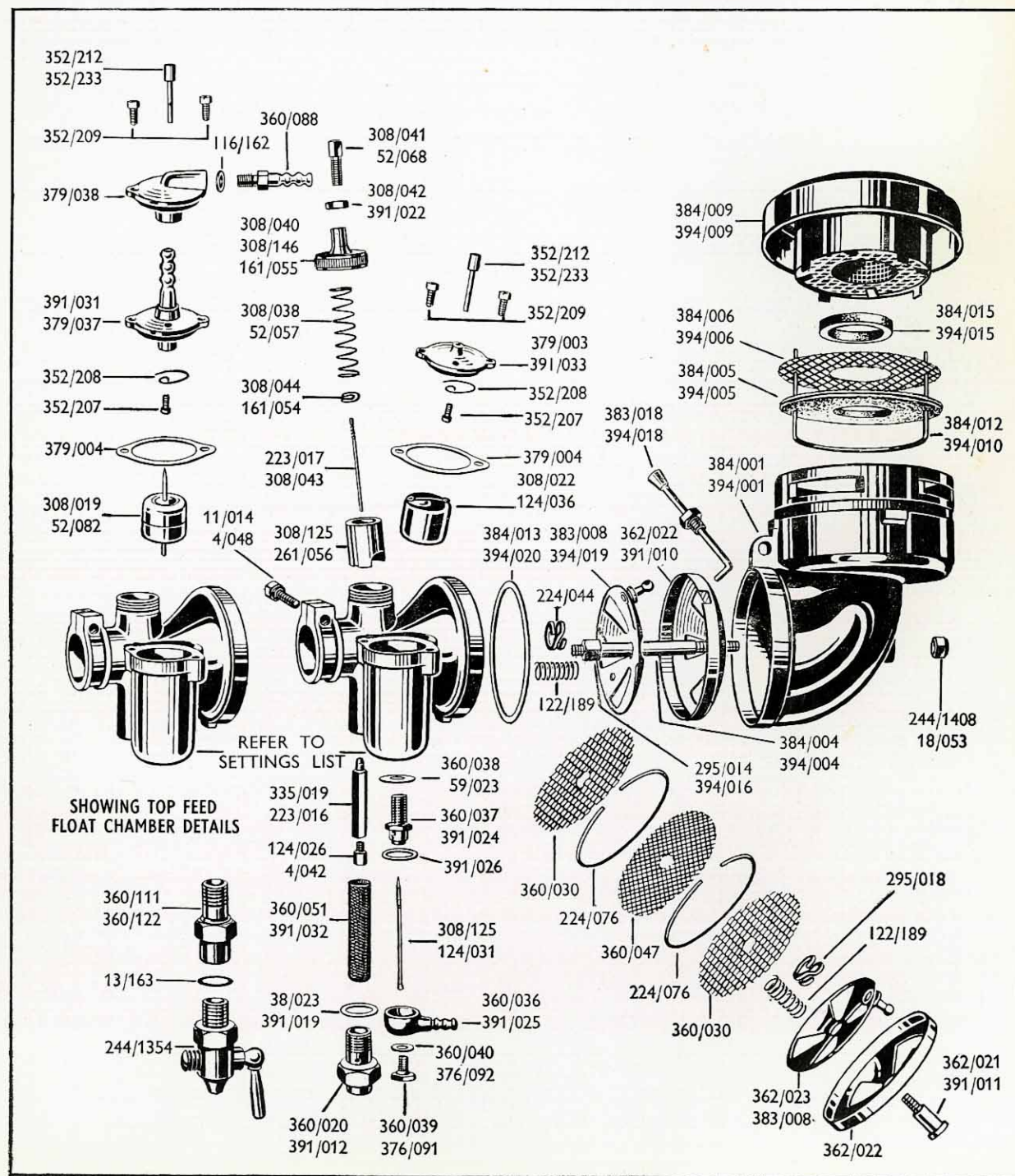

May, 1960.

LIST No. 106/2 (Issue No. 1)
(Supersedes List No. 553)

Spare Parts and Settings List for TYPE Nos. 379 & 391 CARBURETTERS



SPARE PARTS LIST FOR TYPE Nos. 379 and 391 STANDARD CARBURETTERS

Component	379 Standard Carburetter	379 Standard Carburetter when fitted with Type 384/ Air Filter	391 Standard Carburetter	391 Standard Carburetter when fitted with Type 394/ Air Filter
Tickler, complete	—	—	352/233	352/233
Float Chamber Cover Screws ..	352/209	352/209	352/209	352/209
Float Chamber Cover, complete ..	379/003	379/003	391/033	391/033
Tickler Spring	—	—	352/208	352/208
Tickler Spring Screw	—	—	352/207	352/207
Float Chamber Cover Washer ..	379/004	379/004	—	—
Outlet Clamp Screw	11/014	11/014	4/048	4/048
Cable Adjuster	308/041	308/041	52/068	52/068
Cable Adjuster Locknut	308/042	308/042	391/022	391/022
Mixing Chamber Top	308/040	308/040	161/055	161/055
Throttle Valve Spring	308/038	308/038	52/057	52/057
Jet Needle Clip	308/044	308/044	161/054	161/054
Jet Needle	308/043	308/043	223/017	223/017
Throttle Valve	308/125	308/125	261/056	261/056
Float, complete	308/022	308/022	124/036	124/036
Carburetter Body	REFER TO SETTINGS LIST	REFER TO SETTINGS LIST	REFER TO SETTINGS LIST	REFER TO SETTINGS LIST
Needle Jet	335/019	335/019	223/016	223/016
Main Jet	124/026	124/026	4/042	4/042
Petrol Filter	360/051	360/051	391/032	391/032
Jet Cover Washer	38/023	38/023	391/019	391/019
Jet Cover	360/020	360/020	391/012	391/012
Needle Seating Washer	360/038	360/038	59/023	59/023
Needle Seating	360/037	360/037	391/024	391/024
Banjo Top Washer	—	—	391/026	391/026
Float Needle	308/025	308/025	124/031	124/031
Banjo	360/036	360/036	391/025	391/025
Banjo Bolt Washer	360/040	360/040	376/092	376/092
Banjo Bolt	360/039	360/039	376/091	376/091
Air Filter, complete	—	384/1	—	394/1
Filter Plates	360/030	—	391/018	—
Filter Gauze	360/047	—	—	—
Shutter and Knob Assembly ..	362/023	383/008	391/020	394/019
Filter Cover	362/022	362/022	391/010	391/010
Filter Centre Pin	362/021	—	391/011	—
Spring	—	—	122/189	122/189
Spring Washer	295/018	224/044	—	—
Centre Stud	—	384/004	—	394/004
Seal Washer	—	384/013	—	394/020
Filter Pack Assembly	—	384/009	—	394/009
Felt Washer	—	384/015	—	394/015
Gauze for Felt Pad	—	384/006	—	394/006
Felt Pad	—	384/005	—	394/005
Gauze Extractor	—	384/012	—	394/010
Filter Body	—	384/001	—	394/001
Rod Knob and Guide Assembly ..	—	383/018	—	394/018
Locknut	—	244/1408	—	18/053
Nut for Centre Stud	—	295/014	—	394/016
Spacing Ring	—	—	224/076	—
*Cable Nipple	308/051	308/051	4/036	4/036
*Spring Sheath	360/077	360/077	391/023	391/023

*Not Illustrated. Refer to Settings List for identification of special parts which are not included in this Parts List.

**AMAL LTD., HOLDFORD ROAD, WITTON,
BIRMINGHAM 6, ENGLAND**
'Phone : Birmingham, BIRchfields 4571.
(P.B.X. 6 lines) Telegrams : "AMALCARB, 'PHONE.
BIRMINGHAM."

SETTINGS LIST

MANUFACTURER AND ENGINE DETAILS			Carburettor Type No.	Carburettor Body No.	Choke Size	Main Jet	Throttle Valve	Needle Position	Needle Jet	Fl. Cham. Feed	Air Filter	Cable Assembly	Control	SPECIAL DETAILS
Capacity	Model	Eng. Ref.												
80 c.c.	Vertue C80	J.A.P. 22515/1	379/2	379/002	10 mm.	27	No. 2	2	.0745"	Bottom	Std.	244/1392	372/6	
	Holman	J.A.P.	379/3	379/005	12 mm.	40	No. 1	3	.0745"	Bottom	Std.	—	372/4	
80 c.c.	Holman	J.A.P. 22516	379/4	379/005	12 mm.	32	No. 1	3	.0745"	Bottom	Std.	244/1394	372/8	
	Auto-Diesel	J.A.P. 22514/1	379/5	379/001	8 mm.	25	No. 1	2	.0745"	Bottom	Std.	244/1395	372/8	
80 c.c.	Lyons	J.A.P. 22515/3	379/6	379/002	10 mm.	35	No. 1	2	.0745"	Bottom	Std.	244/1396	372/7	
80 c.c.	Sergent	J.A.P. 22516/1	379/7	379/005	12 mm.	35	No. 1	3	.0745"	Bottom	Std.	244/1244	372/6	
	S80	J.A.P. 22515/2	379/8	379/002	10 mm.	35	No. 1	2	.0745"	Bottom	Std.	244/1313	372/4	
80 c.c.	Vertue	J.A.P. 22514	379/9	379/001	8 mm.	22	No. 1	3	.0745"	Bottom	Std.	244/1244	372/4	
	Vertue	J.A.P. 22515	379/10	379/002	10 mm.	35	No. 1	2	.0745"	Bottom	Std.	244/1394	372/4	
	Vertue	J.A.P. 22514/2	379/11	379/001	8 mm.	25	No. 1	2	.0745"	Bottom	Std.	244/1398	12/254	
34 c.c. & 80 c.c.	Vertue	J.A.P. 22514/3	379/12	379/001	8 mm.	22	No. 2	1	.0745"	Bottom	384/1	244/1399	372/5	
80 c.c.	Ransome, Sims and Jefferies ..	J.A.P. 22516/2	379/13	379/005	12 mm.	30	No. 4	2	.0745"	Bottom	384/1	244/1400	372/4	THROTTLE VALVE, 379/019
150 c.c. 80 c.c.	Ransome, Sims and Jefferies ..	J.A.P. 22516/5	379/14	379/005	12 mm.	40	No. 3½	3	.0745"	Bottom	384/2	244/1390	372/4	THROTTLE VALVE, 360/127. AIR FILTER BODY, 384/014
	Landmaster (Garden Master)	J.A.P. 22515/5	379/15	379/002	10 mm.	27	No. 2	2	.0745"	Bottom	384/1	244/1391	372/6	
	General Purpose Engine	J.A.P. 22514/4	379/16	379/001	8 mm.	22	No. 1	2	.0745"	Bottom	Std.	244/1244	372/6	
	Tidemaster	J.A.P. 22516/6	379/18	379/005	12 mm.	35	No. 1	3	.0745"	Bottom	Std.	244/1401	366/1	DRAIN COCK, 244/1354. WASHER FOR DRAINCOCK, 13/163 JET COVER, 360/111
	Vertue, C80/82 ..	J.A.P. 22516/7	379/19	379/005	12 mm.	35	No. 1	2	.0745"	Bottom	Std.	244/1242	372/6	
	Vertue, C80/73 ..	J.A.P. 22515/7	379/20	379/002	10 mm.	35	No. 1	2	.0745"	Bottom	Std.	244/1242	372/4	
34 c.c.	Landmaster	J.A.P. 22514/5	379/22	379/001	8 mm.	22	No. 2	2	.0745"	Bottom	384/1	244/1402	372/6	
80 c.c.	Greens	J.A.P. 22515/8	379/23	379/002	10 mm.	27	No. 1	2	.0745"	Bottom	Std.	244/1131	372/6	
50 c.c.	Coventry Apex Marine	—	379/24	379/002	10 mm.	35	No. 1	2	.0745"	Bottom	360/128 AIR SILENCER	244/1405	372/4	AIR SILENCER { SPRING, 13/203. SPRING WASHER, 365/012. CENTRE STUD, 360/130. SPARES { LOCKNUT, 244/1408. (For other parts refer Spares List and Illustration). JET COVER, 360/122. WASHER FOR DRAINCOCK, 13/163. DRAINCOCK, refer engine makers. MIXING CHAMBER TOP 308/146.
80 c.c.	Austin Burrell ..	J.A.P. 22516/10	379/25	379/005	12 mm.	35	No. 2	2	.0745"	Bottom	360/128 AIR SILENCER	244/1403	355/6	AIR SILENCER { SPRING, 13/203. SPRING WASHER, 365/012. CENTRE STUD, 360/130 SPARES { LOCKNUT, 244/1408 (for other parts refer Spares List and Illustration) JET COVER, 360/111. DRAINCOCK, 244/1354. WASHER FOR DRAINCOCK, 13/163.
	Webb (Lawnmower) ..	J.A.P. 22514/7	379/26	379/001	8 mm.	22	No. 1	2	.0745"	Bottom	Std.	244/1392	372/6	
80 c.c.	Vertue, C80/87 ..	J.A.P. 22516/8	379/28	379/005	12 mm.	35	No. 2	2	.0745"	Bottom	Std.	244/1242	372/4	
80 c.c.	Vertue, C80/88 ..	J.A.P. 22516/9	379/29	379/005	12 mm.	35	No. 2	2	.0745"	Bottom	Std.	244/1242	372/4	

SETTINGS LIST—continued

MANUFACTURER AND ENGINE DETAILS			Carburettor Type No.	Carburettor Body No.	Choke Size	Main Jet	Throttle Valve	Needle Position	Needle Jet	Fl. Cham. Feed	Air Filter	Cable Assembly	Control	SPECIAL DETAILS
Capacity	Model	Eng. Ref.												
75 c.c.	J. E. Shay Trojan (Industrial Engine)	J.A.P. 22515/9 —	379/30 379/31	379/002 379/005	10 mm. 12 mm.	27 30	No. 2 No. 2	2 3	·0745" ·0745"	Bottom Bottom	384/1 Std.	244/1392 —	372/4 —	
34 c.c.	J. E. Shay, Mod. 34B..	J.A.P. 22514/8	379/32	379/001	8 mm.	22	No. 2	2	·0745"	Bottom	384/1	244/1392	355/6	
80 c.c.	Hargreaves Austin Burrell .. (Inboard Motor)	J.A.P. 22515/10 J.A.P. 22516/11	379/33 379/34	379/002 379/005	10 mm. 12 mm.	27 35	No. 2 No. 2	2 2	·0745" ·0745"	Bottom Bottom	384/1 360/128 AIR SILENCER	244/1313 244/1403	372/6 355/6	AIR SILENCER { SPRING, 13/203. SPRING WASHER, 365/012. CENTRE STUD, 360/130 SPARES { LOCKNUT, 244/1408 (for other parts refer Spares List and Illustration)
80 c.c.	Skinner, S80/85 ..	J.A.P. 22515/11	379/36	379/002	10 mm.	27	No. 2	3	·0745"	Bottom	Std.	244/1398	12/254	
75 c.c.	Coventry Apex ..	—	379/37	379/005	12 mm.	35	No. 3	2	·0745"	Bottom	Std.	244/1405	355/2	JET COVER, 360/122. WASHER FOR DRAINCOCK, 13/163. THROTTLE VALVE, 360/050 DRAINCOCK, refer to engine makers. MIXING CHAMBER TOP, 308/146
80 c.c.	Toogood & Jones, Ltd.	J.A.P. 22516/12	379/38	379/005	12 mm.	35	No. 2	2	·0745"	Bottom	Std.	244/1354	372/4	JET COVER, 360/111. WASHER FOR DRAINCOCK, 13/163 DRAINCOCK, 244/1354
80 c.c.	Acrow, Ltd.	J.A.P. 22516/13	379/39	379/005	12 mm.	35	No. 1½	3	·0745"	Bottom	Std.	244/1430	372/4	
	Opancol, S80/23 ..	J.A.P. 22516/3	379/40	379/005	12 mm.	32	No. 2	3	·0745"	Bottom	Std.	—	—	
	Simex Tuson, 34B/9 ..	J.A.P. 22514/9	379/41	379/001	8 mm.	22	No. 2	2	·0745"	Bottom	384/1	—	372/6	
49 c.c.	Teagle, Ltd.	—	379/42	379/002	10 mm.	30	No. 1	3	·0745"	Bottom	Std.	—	372/4	
49 c.c.	Teagle, Ltd.	—	379/43	379/002	10 mm.	30	No. 1	3	·0745"	Bottom	383/1	—	372/4	Refer to AMAL LIST No. 569 FOR TYPE 383/1 AIR FILTER SPARES
49 c.c.	Teagle, Ltd.	—	379/44	379/002	10 mm.	30	No. 1	3	·0745"	Bottom	383/3	—	372/4	Refer to AMAL LIST No. 569 FOR TYPE 383/3 AIR FILTER SPARES
75 c.c.	Trojan	A-9263	379/45	379/005	12 mm.	30	No. 1	2	·0745"	Bottom	383/1	—	—	Refer to AMAL LIST No. 569 FOR Type 383/1 AIR FILTER SPARES
34 c.c.	Qualcast Mower ..	J.A.P. 22514/10	379/46	379/001	8 mm.	22	No. 2	2	·0745"	Bottom	Std.	—	372/6	
34 c.c.	Cooper, Stewart ..	J.A.P. 22514/6	379/47	379/001	8 mm.	22	No. 2	2	·0745"	Bottom	Std.	—	372/4	
75 c.c.	Coventry Apex, Mod. 70	—	379/49	379/002	10 mm.	30	No. 1½	2	·0745"	Bottom	360/128 AIR SILENCER	244/1405	355/2	AIR SILENCER { SPRING, 13/203. SPRING WASHER, 365/012. CENTRE STUD, 360/130 SPARES { LOCKNUT, 244/1408 (for other parts refer Spares List and Illustration) MIXING CHAMBER TOP, 308/146 JET COVER, 360/122. WASHER FOR DRAINCOCK, 13/163. DRAINCOCK refer to eng. makers
80 c.c.	B.S.A., Co. Ltd. ..	—	379/50	379/002	10 mm.	35	No. 3	2	·0745"	Bottom	Std.	—	—	PETROL FILTER FOR NEEDLE SEATING 379/011. NEEDLE SEATING, 379/010
288 c.c.	Ransome, Sims and Jefferies ..	J.A.P. 22516/16	379/51	379/005	12 mm.	40	No. 3½	4	·0745"	Bottom	244/1463 ELBOW AND STRAN. ASSY.	244/1488	20/3	THROTTLE VALVE, 360/127 ELBOW AND STRANGLER ASSEMBLY { CENTRE STUD, 383/017. Other parts as indicated SPARES { under 384/1 AIR FILTER ASSEMBLY
	Holt	J.A.P. 22516/14	379/52	379/005	12 mm.	32	No. 2	2	·0745"	Bottom	384/1	—	372/4	
34 c.c.	Hewitt, S-34	J.A.P. 22514/11	379/53	379/001	8 mm.	20	No. 2	2	·0745"	Bottom	Std.	—	372/8	
49 c.c.	Teagle, Ltd.	—	379/54	379/002	10 mm.	25	No. 1	3	·0745"	Bottom	Std.	—	355/4	
30 c.c.	Stuart Turner Ltd. ..	60568	379/55	379/001	8 mm.	25	No. 1	3	·0745"	Bottom	Std.	—	—	
	Suffolk Pony Mk III	50/G/1/2 2A	379/56	379/022	12 mm.	35	No. 3	2	·0745"	Bottom	Std.	—	355/5	THROTTLE VALVE, 308/149. VALVE STOP SCREW, 379/015 STOP SCREW LOCKNUT, 379/016. CARBURETTOR BODY, 379/022, opp. STD.

SETTINGS LIST—continued

MANUFACTURER AND ENGINE DETAILS			Carburettor Type No.	Carburettor Body No.	Choke Size	Main Jet	Throttle Valve	Needle Position	Needle Jet	Fl. Cham. Feed	Air Filter	Cable Assembly	Control	SPECIAL DETAILS
Capacity	Model	Eng. Ref.												
80 c.c.	J. A. Prestwich ..	J.A.P. 22515/12	379/58	379/002	10 mm.	35	No. 2	2	.0745"	Bottom	—	244/1391	372/6	
	Ransome, Sims and Jefferies, Mod. 4/3 Engine	22516/17	379/59	379/005	12 mm.	50	No. 3½	2	.0745"	Bottom	244/1463 ELBOW AND STRAN. ASSY.	244/1488	20/3	THROTTLE VALVE, 360/127 ELBOW AND STRANGLER ASSEMBLY {CENTRE STUD, 383/017. Other parts as indicated SPARES {under 384/1 AIR FILTER ASSEMBLY
34 c.c.	Outboard Engine ..	J.A.P. 22514/12	379/60	379/001	8 mm.	22	No. 2	2	.0745"	Bottom	360/128 AIR SILENCER	244/1520	372/4	AIR SILENCER {SPRING, 13/203. SPRING WASHER, 365/012. CENTRE STUD, 360/130 SPARES {LOCKNUT, 244/1408 (for other parts refer Spares List and Illustration)
	J. E. Shay	J.A.P. 22515/13	379/61	379/007	10 mm.	27	No. 2	2	.0745"	Top	384/1	244/1392	372/4	FLOAT AND NEEDLE, COMPLETE, 308/019. FLOAT CHAMBER COVER, complete, 379/037
34 c.c.	Outboard Engine ..	J.A.P. 22514/13	379/62	379/001	8 mm.	22	No. 2	2	.0745"	Bottom	360/128 AIR SILENCER	244/1408	355/2	AIR SILENCER {SPRING, 13/203. SPRING WASHER, 365/012. CENTRE STUD, 360/130 SPARES {LOCKNUT, 244/1408 (for other parts refer Spares List and Illustration)
	Ransome, Sims and Jefferies, Mod. 4/3 Engine	J.A.P. 22516/18	379/63	379/005	12 mm.	50	No. 3½	2	.0745"	Bottom	244/1463 ELBOW AND STRAN. ASSY.	—	20/3	THROTTLE VALVE, 360/127 ELBOW AND STRANGLER ASSEMBLY {CENTRE STUD, 383/017. Other parts as indicated SPARES {under 384/1 AIR FILTER ASSEMBLY
80 c.c.	B.S.A. Co., Ltd. .. (Industrial Engine)	—	379/65	379/002	10 mm.	35	No. 3	2	.0745"	Bottom	—	—	—	PETROL FILTER FOR NEEDLE SEATING 379/011 NEEDLE SEATING, 379/010
65 c.c.	Dunkley Scooter Popular	—	379/66	379/007	10 mm.	30	No. 1½	1	.0745"	Top	SEE SPECIAL DETAILS	244/1453	—	FLOAT AND NEEDLE, COMPLETE, 308/019. FLOAT CHAMBER COVER, COMPLETE, 379/038 AIR FILTER AS STANDARD EXCEPT NO GAUZE FITTED. SHUTTER AND KNOB, 383/008 AIR FILTER COVER, 362/039. FUEL INLET CONNECTION, 360/088. FIBRE WASHER, 116/162
	Nash	J.A.P. 22514/14	379/69	379/001	8 mm.	22	No. 2	2	.0745"	Bottom	Std.	—	372/4	
	Lister	J.A.P. 22514/15	379/70	379/001	8 mm.	22	No. 2	2	.0745"	Bottom	Std.	—	—	
	Spiratiller	J.A.P. 22514/16	379/71	379/001	8 mm.	22	No. 2	2	.0745"	Bottom	Std.	—	372/4	
34 c.c.	Atco Mower	J.A.P. 22514/18	379/74	379/001	8 mm.	22	No. 2	1	.0745"	Bottom	Std.	—	Ref. Eng. makers	
75 c.c.	Coventry Apex., Mod. 70	—	379/76	379/002	10 mm.	32	No. 2	1	.0745"	Bottom	360/128 AIR SILENCER	244/1405	372/4	AIR SILENCER {SPRING, 13/203. SPRING WASHER, 365/012. CENTRE STUD, 360/130 SPARES {LOCKNUT, 244/1408 (for other parts refer Spares List and Illustration) MIXING CHAMBER TOP, 308/146. JET COVER, 360/122. WASHER FOR DRAINCOCK, 13/163. DRAINCOCK refer to eng. makers.
	J. A. Prestwich ..	J.A.P. 22515/14	379/77	379/002	10 mm.	27	No. 2	2	.0745"	Bottom	Std.	—	—	
34 c.c.	Ransome, Sims and Jefferies (Mower) ..	J.A.P. 22514/17	379/78	379/001	8 mm.	22	No. 1	2	.0745"	Bottom	Std.	—	372/4	
80 c.c.	J. A. Prestwich ..	J.A.P. 22515/15	379/79	379/002	10 mm.	27	No. 2	2	.0745"	Bottom	Std.	—	372/4	
	Garden Plant Hire, Ltd.	J.A.P. 22515/16	379/80	379/002	10 mm.	27	No. 1	2	.0745"	Bottom	384/1	—	372/9	
	Ransome, Sims and Jefferies, Mod. 4/3 Eng.	J.A.P. 22516/19	379/81	379/005	12 mm.	50	No. 3½	2	.0745"	Bottom	244/1463 ELBOW AND STRAN. ASSY.	—	20/5	THROTTLE VALVE, 360/127 ELBOW AND STRANGLER ASSEMBLY {CENTRE STUD, 383/017. Other parts as indicated SPARES {under 384/1 AIR FILTER ASSEMBLY
	J. A. Prestwich ..	J.A.P. 22516/20	379/82	379/005	12 mm.	35	No. 1	2	.0745"	Bottom	Std.	—	372/4	
	J. A. Prestwich ..	J.A.P. 22516/21	379/83	379/005	12 mm.	32	No. 2	2	.0745"	Bottom	383/3	—	372/4	Refer to AMAL LIST No. 569 FOR TYPE 383/3 AIR FILTER SPARES
	J. A. Prestwich ..	J.A.P. 22516/24	379/85	379/005	12 mm.	35	No. 2	2	.0745"	Bottom	360/128 AIR FILTER	—	372/4	AIR SILENCER {SPRING, 13/203. SPRING WASHER, 365/012. CENTRE STUD, 360/130 SPARES {LOCKNUT, 244/1408 (for other parts refer to Spares List and Illustration)
34 c.c.	Atco Mower	J.A.P. 22514/21	379/86	379/001	8 mm.	22	No. 1	3	.0745"	Bottom	Std.	244/1587	Refer Engine Makers	
80 c.c.	Go-Kart	J.A.P. 22516/22	379/87	379/005	12 mm.	35	No. 2	3	.0745"	Bottom	Std.	—	—	
	J. A. Prestwich ..	J.A.P. 22516/25	379/89	379/005	12 mm.	50	No. 3½	2	.0745"	Bottom	244/1463 ELBOW AND STRAN. ASSY.	—	20/4	THROTTLE VALVE, 360/127 ELBOW AND STRANGLER ASSEMBLY {CENTRE STUD, 383/017. Other parts as indicated SPARES {under 384/1 AIR FILTER ASSEMBLY
	Intermit Model 34 ..	J.A.P. 22514/22	379/90	379/001	8 mm.	22	No. 2	2	.0745"	Bottom	Std.	—	372/9	

SETTINGS LIST—continued

MANUFACTURER AND ENGINE DETAILS			Carburettor Type No.	Carburettor Body No.	Choke Size	Main Jet	Throttle Valve	Needle Position	Needle Jet	Fl. Cham. Feed	Air Filter	Cable Assembly	Control	SPECIAL DETAILS
Capacity	Model	Eng. Ref.												
	Taurus	J.A.P. 22516/23	379/91	379/005	12 mm.	35	No. 1	2	.0745"	Bottom	Std.	—	—	
160 c.c.	Industrial Engine ..	J.A.P. 22670	391/1	391/004	11/16"	70	No. 4	2	.107"	Top	394/1	—	372/5	FLOAT CHAMBER COVER, COMPLETE, 391/031. FLOAT AND NEEDLE, COMPLETE, 52/082 TICKLER, COMPLETE, 352/212
	Ransome, Sims and Jefferies, Mod. 5 Eng.	J.A.P. 22772	391/2	391/005	17/32"	60	No. 4	2	.107"	Bottom	394/2	—	20/3	AIR FILTER BODY, 394/024
160 c.c.	Industrial Engine ..	J.A.P. 22670/2	391/3	391/004	11/16"	70	No. 4	2	.107"	Top	Std.	—	372/5	FLOAT CHAMBER COVER, COMPLETE, 391/031. FLOAT AND NEEDLE, COMPLETE, 52/082 TICKLER, COMPLETE, 352/212
160 c.c.	Landmaster	J.A.P. 22772/1	391/4	391/008	11/16"	70	No. 4	3	.106"	Bottom	394/1	244/1572	12/614	
	Ransome, Sims and Jefferies, Mod. 5 Eng.	J.A.P. 22670/3	391/5	391/005	17/32"	60	No. 4	2	.107"	Bottom	394/2	—	20/3	AIR FILTER BODY, 394/024
160 c.c.	Landmaster	J.A.P. 22670/4	391/6	391/008	11/16"	80	No. 2	3	.106"	Bottom	394/1	244/1572	12/614	DRAINCOCK, 244/1354. WASHER FOR DRAINCOCK, 13/163. JET COVER, 391/034.
	Allum, 4/3 Eng. ..	J.A.P. 22772/2	391/7	391/008	11/16"	80	No. 4	3	.106"	Bottom	394/1	—	372/9	
	Ransome, Sims and Jefferies, Mod. 5 Eng.	J.A.P. 22670/7	391/10	391/005	17/32"	60	No. 4	2	.107"	Bottom	394/2	—	20/4	AIR FILTER BODY, 394/024
	J. A. Prestwich ..	J.A.P. 22670/8	391/11	391/008	11/16"	70	No. 4	2	.106"	Bottom	394/1	—	—	
	J. A. Prestwich ..	J.A.P. 22670/8	391/13	391/008	11/16"	75	No. 4	3	.106"	Bottom	394/1	—	—	

GUARANTEE.—The Company take all possible reasonable care in the manufacture and the quality of their products. Purchasers are informed that, any part proved to be defective in manufacture or quality, and returned to the works within six months of its purchase new, will be replaced. The Company must respectfully point out however, that its responsibility and that of its agents, stockists and dealers, is limited to this Guarantee, and that they cannot under any circumstances, be held responsible for any loss or for any contingent or resulting liability arising through any defect. These conditions of sale and use also apply when the Company's products form part of the original equipment of machines purchased new.

IceniCAM Information Service

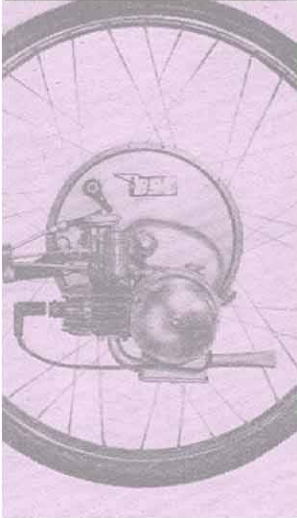

www.icenicam.org.uk