



August, 1957

LIST No. 441

Issue No. 3

# SPARE PARTS LIST for T.T. CARBURETTORS

## MIXING CHAMBER PARTS (Illustrations)

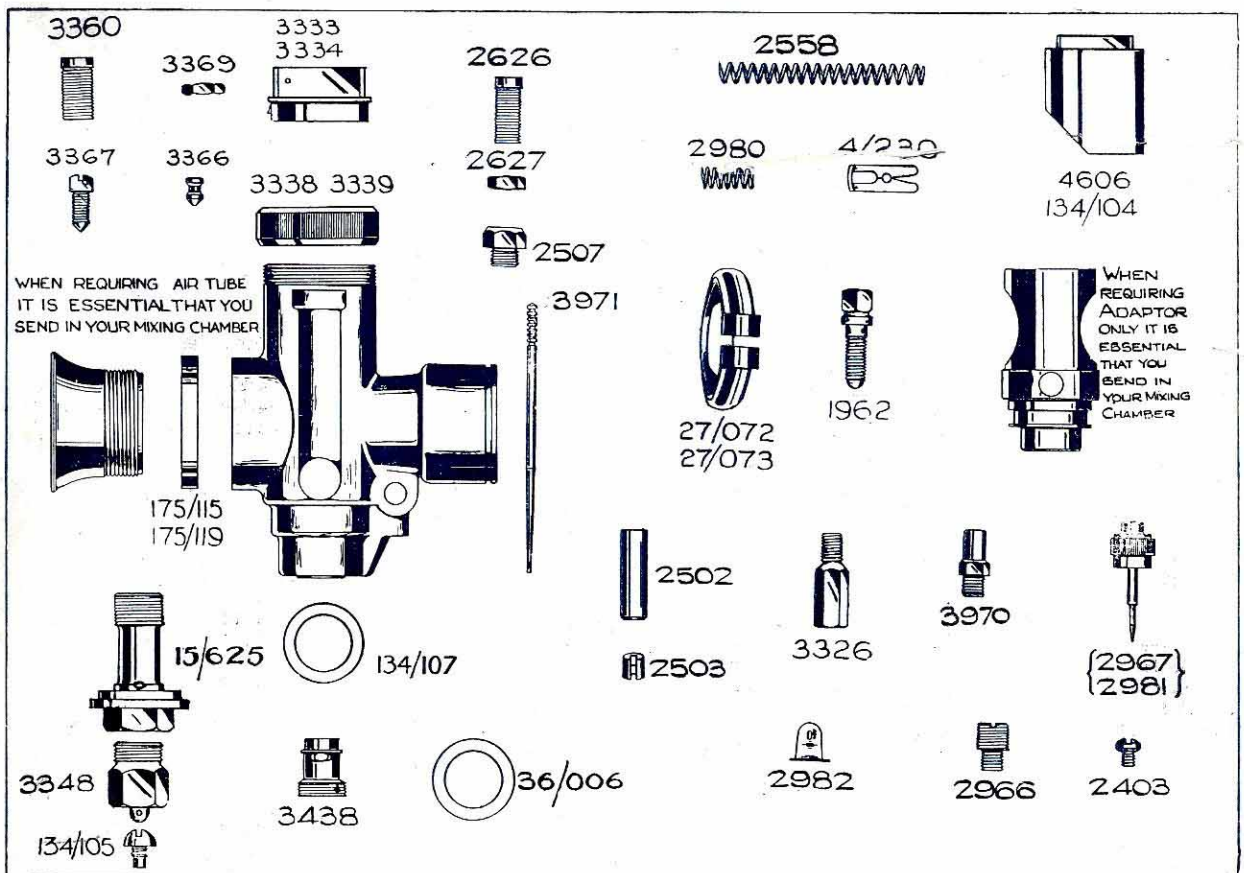

**AMAL LTD., HOLDFORD ROAD, WITTON,  
BIRMINGHAM 6, ENGLAND**

'Phone : Birmingham, BIRchfields 4571.  
(P.B.X. 6 lines)

Telegrams : "AMALCARB, 'PHONE.  
BIRMINGHAM."



## List of MIXING CHAMBER PARTS

Component	For Type 15T.T.	For Type 10T.T.	
Mixing Chamber Body (Light Metal) .. .. .	} Specify Engine details	} Specify Engine details	
Mixing Chamber Top .. .. .			3333
Mixing Chamber Cap .. .. .	3339	3338	
Air Cable Adjuster .. .. .	2626	2626	
Air Cable Adjuster Locknut .. .. .	2627	2627	
Throttle Cable Adjuster .. .. .	3360	3360	
Throttle Cable Adjuster Locknut .. .. .	3369	3369	
Lock Plunger for Mixing Chamber Top .. .. .	3366	3366	
Adjusting Screw for Lock Plunger .. .. .	3367	3367	
Air Bore Top .. .. .	2507	2507	
Choke Adaptor, 1" Bore	} Machined in position with Mixing Chamber Body which should be sent to Amal, Ltd. .. .. .	—	
Choke Adaptor, 1 1/16" Bore		175/109	—
Choke Adaptor, 1 1/8" Bore		175/102	175/108
Choke Adaptor, 1 3/32" Bore		—	175/272
Choke Adaptor, 1 1/16" Bore		—	175/101
Main Jet .. .. .	3326	3326	
Jet Choke Tube .. .. .	3438	3438	
Needle Jet .. .. .	3970	3970	
Jet Needle .. .. .	3971	3971	
Jet Needle Clip .. .. .	4/230	4/230	
Throttle Valve (Please state number of cut-away) .. .. .	4606	134/104	
Throttle Valve Spring .. .. .	2558	2558	
Air Valve .. .. .	2502	2502	
Air Valve Spring .. .. .	2558	2558	
Jet Holder .. .. .	15/625	15/625	
Jet Holder Plug Screw .. .. .	3348	3348	
Adaptor Washer .. .. .	134/107	134/107	
Float Chamber Arm Washer .. .. .	36/006	36/006	
Pilot Needle .. .. .	2981/2967	2981/2967	
Pilot Needle Insert .. .. .	2966	2966	
Pilot Needle Spring .. .. .	2980	2980	
Pilot Needle Spring Catch .. .. .	2982	2982	
Nipple Holder for Air Valve .. .. .	2503	2503	
Carburettor Cable Nipple .. .. .	2629	2629	
Small Plug Screw .. .. .	2403	2403	
Adaptor Location Peg .. .. .	134/105	134/105	
Outlet Clip for 1 1/2" Outlet	} State Material of Mixing Chamber Body, i.e., Brass or Light Metal	—	
Outlet Clip for 1 1/4" Outlet		27/073	—
Outlet Clip for 1 3/8" Outlet		27/073	27/072
Outlet Clip for 1 1/2" Outlet		—	27/072
Outlet Clip Screw .. .. .	1962	1962	
Air Intake Tube, 1" Bore	} Machined in position with Mixing Chamber Body which should be sent to Amal, Ltd.	—	
Air Intake Tube, 1 1/16" Bore		175/114	—
Air Intake Tube, 1 1/8" Bore		175/113	—
Air Intake Tube, 1 3/32" Bore		—	175/118
Air Intake Tube, 1 1/16" Bore		—	185/121
Lock Ring for Air Intake Tube .. .. .	175/115	175/117	
		175/119	

# AMAL

## FLOAT CHAMBER PARTS (Illustrations)

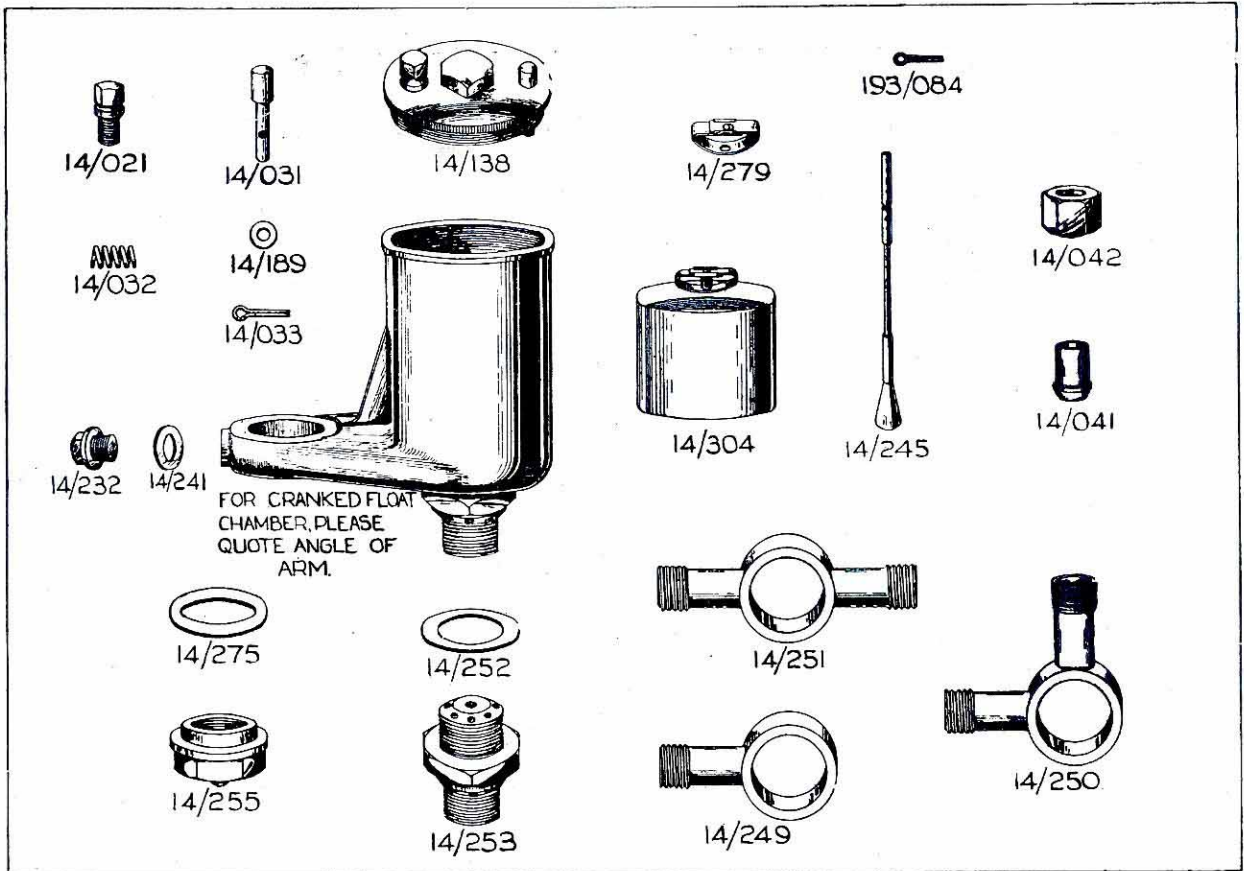

The above illustrations cover Float Chambers  
 Type Nos. 14/532, 14/533, 14/534, 14/538 and 15/1812.

MOST PARTS OF FLOAT CHAMBERS TYPE No's. 14/064 and 14/601  
 are common to the above.

Refer to page 4 for full details.



LIST No. 441

## List of FLOAT CHAMBER PARTS

Component	14/064	14/601	14/532	14/533	14/534	14/538	15/1812
Float Ch'b'r comp'te	14/064	—	—	—	—	—	—
Ditto	—	14/601	—	—	—	—	—
Ditto	—	—	14/532	14/533	—	14/538	—
Ditto	—	—	—	—	14/534	—	—
Ditto	—	—	—	—	—	—	—
Fl't Ch'b'r Body only	14/314	—	—	—	—	—	15/1812
Ditto	—	14/316	—	—	—	—	—
Ditto	—	—	14/225R	14/225R	14/225R	14/217R	15/1812B
Cover complete	14/138	14/138	14/138	14/138	14/138	14/138	14/138
Cover Lock Screw	14/021	14/021	14/021	14/021	14/021	14/021	14/021
Tickler	14/031	14/031	14/031	14/031	14/031	14/031	14/031
Tickler Spring	14/032	14/032	14/032	14/032	14/032	14/032	14/032
Tickler Cotter Pin	14/033	14/033	14/033	14/033	14/033	14/033	14/033
Tickler Washer	14/189	14/189	14/189	14/189	14/189	14/189	14/189
Float Needle	14/024S	14/024S	—	—	—	—	—
Float Needle	—	—	14/245	14/245	14/245	14/245	14/245
Float	14/017	14/017	—	—	—	—	—
Float	—	—	14/304	14/304	14/304	14/304	14/304
Float Bow Spring	14/279	14/279	14/279	14/279	14/279	14/279	14/279
Float Securing Cotter Pin	—	—	193/084	193/084	193/084	193/084	193/084
Needle Valve Seating	—	—	14/253	14/253	14/253	14/253	14/253
Needle Valve Seating Washer	—	—	14/252	14/252	14/252	14/252	14/252
Body Base Plug Screw	—	—	14/232	14/232	14/232	14/232	14/232
Washer for Body Base Plug Screw	—	—	14/241	14/241	14/241	14/241	14/241
Banjo (Single)	14/035	14/035	—	—	—	—	—
Banjo (Single)	—	—	—	—	14/249	—	14/249
Banjo (Twin) 90°	14/043	—	—	—	—	—	—
Banjo (Twin) 90°	—	—	—	14/250	—	14/250	—
Banjo (Twin) 180°	14/173	—	—	—	—	—	—
Banjo (Twin) 180°	—	—	14/251	—	—	—	—
Washers for Banjo	14/037	14/037	14/275	14/275	14/275	14/275	14/275
Banjo Nut	14/036	14/036	—	—	—	—	—
Banjo Nut	—	—	14/255	14/255	14/255	14/255	14/255
Flex. Pipe Connection for Mix. Chbr.	—	—	—	—	—	14/218	—
Flex. Pipe Connection for Fl. Chbr.	—	—	—	—	—	14/219	—
Washer for Float Chbr. Connection	—	—	—	—	—	120/036	—
Petrol Union Nut	14/042	14/042	14/042	14/042	14/042	14/042	14/042
Petrol Union Nipple	14/041	14/041	14/041	14/041	14/041	14/041	14/041

**GUARANTEE.**—The Company take all possible reasonable care in the manufacture and the quality of their products. Purchasers are informed that, any part proved to be defective in manufacture or quality, and returned to the works within six months of its purchase new, will be replaced. The Company must respectfully point out however, that its responsibility and that of its agents, stockists and dealers, is limited to this Guarantee, and that they cannot, under any circumstances, be held responsible for any loss or for any contingent or resulting liability arising through any defect. These conditions of sale and use also apply when the Company's products form part of the original equipment of machines purchased new.

500/8/57. W.

Printed in England.

**AMAL LTD., HOLDFORD ROAD, WITTON,  
BIRMINGHAM 6, ENGLAND**

'Phone : Birmingham, BIRchfields 4571.  
(P.B.X. 6 lines)

Telegrams : "AMALCARB, 'PHONE,  
BIRMINGHAM."

# IceniCAM Information Service

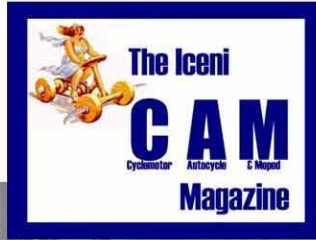

[www.icenicam.org.uk](http://www.icenicam.org.uk)